

Zhejiang Yilida Ventilator Co., Ltd.  
浙江亿利达风机股份有限公司

Yilida Road, Hengjie, Luqiao District, Taizhou City, Zhejiang, China P.C: 318056  
中国浙江台州市路桥区横街亿利达路

Tel : +86 576 82656000 +86 576 82658900  
Fax : +86 576 82655758  
E-mail : info@yilida.com

Hot Line ( 全球服务热线 ) : 400 1135 666 International Trade ( 国际贸易 ) : +86 576 82622666 [www.yilida.com](http://www.yilida.com)

Version Number: A201301 The rights of final interpretation of this brochure belongs to Yilida.  
© 2013 All Rights Reserved by Yilida

版本号: A201301 该手册最终解释权归亿利达股份公司所有  
© 2013 亿利达拥有版权并保留所有权利

Reference:YLD-CY-2013, April 2013

本样本中所述的风机特性, 如尺寸、性能参数等, 本公司保留更改的权利, 恕不另行通知; 如有不明之处, 请来电询问。  
This fan features described in the sample, such as size, performance parameters, the Company reserves the right to change without notice; if unknown place, please call us.

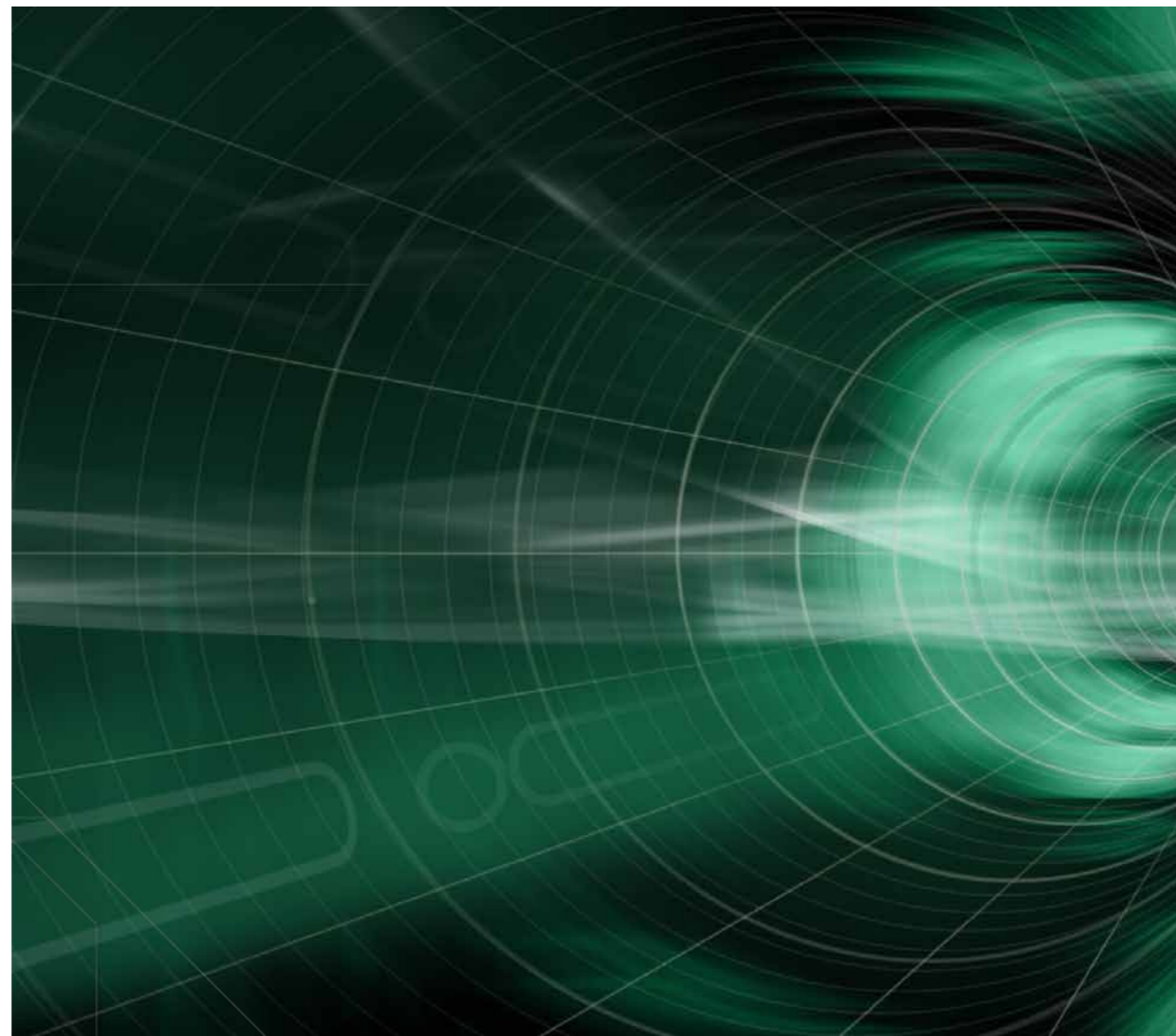

# Yilida Air Conditioning Ventilation Technical Manual

Belt-driven  
皮带驱动

**Yilida**®

The Smart Air

风机应用部分	Fan Applications	风机产品部分	Fan Products
AMCA Introduction AMCA 介绍	002-005	SYT	027-056
Quantities, Symbols and Units 量、符号与单位	006	SYD	057-094
Fan Basics and Applications 风机基础及应用	007-012	SYQ	095-128
Fan Vibration and Balancing 风机的振动和平衡	013-019	SYH	129-162
The Basics of Sound 风机的声音基础	020-023	SYQS	163-200
The Effects of Temperature and Altitude 温度与海拔对选型的影响	024-026	SYDS	201-230

## A). 什么是AMCA 国际?

空气运动及控制协会 (AMCA 国际), 是一家非盈利性的国际性组织, 它的成员大多是世界各国与空气系统有关的生产商, 涉及产品主要包括(但也不仅限于): 工商业和家用的风机、百叶窗、风阀、空气幕、空气流量测量装置、噪声衰减器及其它空气系统组件。

AMCA 的使命是促进空气运动及控制行业与公众利益一致并健康发展。AMCA 国际是一种非常有价值的资源, 同时也是行业自律的强有力组织。人们不论是购买还是指定风机、风阀和百叶窗, 都一定要充分了解 AMCA 国际认证额定值印章的价值。

在过去的 90 年中, AMCA 国际代表空气运动及控制行业发展的行业领军者, 为其会员提供下列有利价值的服务:

- 1) 认证额定值程序
- 2) 独一无二的国家级检测实验室
- 3) 参与标准的制定
- 4) AMCA 认可的独立实验室 (在新加坡和韩国)
- 5) 行业统计和预测报告

## A). What is AMCA International?

The Air Movement and Control Association (AMCA International), Inc. is a not-for-profit international association of the world's manufacturers of related air system equipment, primarily, but not limited to: fans, louvers, dampers, air curtains, airflow measurement stations, acoustic attenuators, and other air system components for the industrial, commercial and residential markets.

The association's mission is to promote the health and growth of the air movement and control industry consistent with the interest of the public. AMCA International is a valuable resource and a strong means of self regulation for our industry. People who buy and specify fans, dampers, and louvers need to be aware of the value of the AMCA International Certified Ratings Seal.

During the last 90 years of representing the air movement and control industry (over fifty years as its consolidated voice), AMCA International has provided value to its membership with the following services:

- 1) Certified Ratings Program
- 2) Unique state-of-the art testing laboratory
- 3) Participation in the development of standards
- 4) Independent AMCA accredited laboratories in Singapore, Korea
- 5) Industry statistics and forecasting reports

## B). 认证额定值程序 (CRP)

1) AMCA 国际的认证额定值程序 (CRP), 保证产品系列已经过测试, 及其额定值已达到 AMCA 国际的测试标准和额定要求。

2) 当产品已经过测试, 及其样本已经提交给 AMCA 国际的工作人员批准, AMCA 的性能印章会显示在样本和设备上。要维持额定值的认证, 每一个经授权的产品系列都要接受 3 年一次的重复检测。发布的性能参数都经过核实为准确并有效的。

3) AMCA 国际的认证额定值印章向空气运动及控制设备的采购员、专业人士和终端用户保证, 生产商公布的额定值是可靠和准确的。

4) AMCA 的认证额定值程序向采购员和专业人士保证, 各竞争者的额定值都是基于标准的测试方法和程序得出, 并由 AMCA 国际作为一个公平的权威机构来进行审核。

5) 所有 AMCA 认证的产品都列入网站, 以便您可以验证出您购买的产品是在行列中。你在购买之前, 请检查 AMCA 在线目录的认证产品 [www.amca.org](http://www.amca.org)。

## B). Certified Rating Program (CRP)

1) AMCA International's Certified Ratings Program (CRP) assures that a product line has been tested and rated in conformance with AMCA International's test standards and rating requirements.

2) Performance seals may be displayed in literature and on equipment after a product has been tested and its cataloged ratings have been submitted to and approved by AMCA International's staff. To maintain a ratings certification, each licensed product line is subject to retesting every 3 years. Published performance is checked for accuracy and validity.

3) An AMCA Certified Ratings Seal gives the buyer, specifier, and end-user of air movement and control equipment assurance that published ratings are reliable and accurate.

4) The AMCA certified ratings program assures buyers and specifiers that competitors' ratings are based on standard test methods and procedures, and are subject to review by AMCA International as an impartial authority.

5) All AMCA certified products are listed on line, so you can verify that the product you are buying is listed. Before you buy, check out the AMCA online Directory of Certified Products at [www.amca.org](http://www.amca.org).

### C) 风机的测试及标准

### C). Fans Testing and Standards

AMCA 国际的实验室可以对风机进行以下的测试:

1) 风机的空气性能测试包括:

- 风机性能的发展。
- 气流、压力、功率和效率的测量。

适用于空气性能测试的测试标准,包括:

- AMCA 标准 210-07, 实验室测试风机气动性能额定值认证的方法。
- AMCA 标准 220-05, 空气幕机组的测试方法。
- AMCA 标准 230-07, 实验室测试空气循环风机额定值的方法。
- AMCA 标准 240-06, 实验室测试正压通风机额定值的方法。

2) 风机的声音测试包括:

- 进口的声功率。
- 出口的声功率。
- 总声功率。

适用于声音测试的测试标准,包括:

- AMCA 标准 300-08, 混响室测试风机声音的方法。

3) 风机的能源效率测试包括:

- 风机效率等级 (FEG) 对风机的效率进行分级。

适用于风机的能源效率测试的测试标准,包括:

- AMCA 标准 205-10, 风机能源效率分级。



1) Air Performance Testing includes:

- Development of the fan curves.
- Measurement of airflow, pressure, power and efficiency.

Test standards that apply to air performance testing include:

- AMCA 210-07, Laboratory Methods of Testing Fans for Aerodynamic Performance Rating.
- AMCA 220-05, Test Methods for Air Curtain Units.
- AMCA 230-07, Laboratory Methods of Testing Air Circulator Fans for Rating.
- AMCA 240-06, Laboratory Method of Testing Positive Pressure Ventilators for Rating.

2) Sound Testing includes:

- Inlet sound power.
- Outlet sound power.
- Total sound power.

Test standards that apply to air performance testing include:

- AMCA 300-08, Reverberant Room Method for Sound Testing of Fans.

3) Energy Efficiency Testing includes:

- The fans shall be classified for their fan efficiency by using the Fan Efficiency Grade (FEG).

Test standards that apply to air performance testing include:

- AMCA 205-10, Energy Efficiency Classification for Fans.



### D) 亿利达与 AMCA 国际的关系

### D). Relationship between Yilida and AMCA International, Inc.

1) 亿利达是 AMCA 国际的会员单位。

2) 亿利达建有国内首家 AMCA 标准实验室——按 AMCA 标准建设的全性能实验室。

3) 大部分的产品都通过 AMCA 认证额定值程序 (CRP) 的测试, 相应的样本都获得 AMCA 国际的工作人员批准, 这些产品及其样本已被批准使用 AMCA 国际的认证额定值印章。

4) 亿利达获得的认证额定值印章, 包括: 风机的空气性能, 风机的声音, 风机效率等级 (FEG)。

注意:

1) 有些生产厂商的印刷品中有下列类似阐述“按照 AMCA 标准进行测试”, 但请注意这与“产品被获准使用 AMCA 国际的认证额定值印章”有本质区别。印有类似语句的印刷品仅仅表明该产品采用 AMCA 公布的标准进行测试, 但是其测试的数据不会被 AMCA 承认。

2) 另一个容易引致误会的方面是 AMCA 国际的认证额定值印章与 AMCA 会员证书之间的差异。有些生产厂商会将 AMCA 会员证书印在产品目录上, 这容易让人误解为其产品已通过 AMCA 的测试及认证。红白的 AMCA 会员证书仅仅代表其为 AMCA 国际的会员, 只有蓝黄色和绿黄色的认证额定值印章, 才表明该产品是通过 AMCA 认证额定值程序 (CRP) 的测试, 并被批准使用 AMCA 国际的认证额定值印章。如图 1 所示。

1) Yilida is a member of AMCA International, Inc.

2) Yilida has built the first AMCA Standard Laboratory in China. The laboratory was built in accordance to the AMCA Standard.

3) Most of the products are tested and certified by AMCA Certified Rating Program (CRP), and their catalog ratings are approved by AMCA International's staff. All these products and their catalogs are approved to use the AMCA International Certified Ratings Seal.

4) The Certified Rating Seals include: Air Performance, Sound and Fan Efficiency Grade (FEG).

Note:

1) Some manufacturers have printed the following statement: "tested in accordance with AMCA standards" in their catalogs. Please note that there are essentially different from the statement of "the products are approved to use the AMCA International Certified Ratings Seal". These manufactures statements mean that their products are tested in accordance with AMCA Standards, but the tested data are not recognized and approved by the AMCA International.

2) Another statement that can easily lead to misunderstanding is the difference between the "AMCA International Certified Ratings Seal" and the "AMCA Membership Certificate". Some manufacturers have printed the "AMCA Membership Certificate" in their catalogs. This is misleading to let people believe that their products have tested and certified by AMCA. The "AMCA Membership Certificate" (red and white color) indicates that the manufacturer is a member of the AMCA International only. Only the "AMCA International Certified Ratings Seal" (yellow and green, yellow and blue color) symbols indicates that the products have been tested through the AMCA International Certified Rating Program and have been approved to use the "AMCA International Certified Ratings Seal". (Fig.1)



图1 Fig.1

本公司承诺样本中贴有 AMCA 国际的认证额定值印章 的风机, 性能都已经通过 AMCA 认证额定值程序 (CRP) 的测试, 并被批准使用 AMCA 国际的认证额定值印章。

Yilida committed that all fans and its catalogs affixed with the AMCA International Certified Ratings Seal. The fans are tested and certified by AMCA Certified Rating Program (CRP) and are approved to use the AMCA International Certified Rating Seal.



### 1. 常用基本符号 Basic Symbols

名称	Designation	Symbol/符号	Unit/SI单位	名称	Designation	Symbol/符号	Unit/SI单位
面积	The measure of area	A	m <sup>2</sup>	速度	Speed	c	m/s
体积	Volume	V	m <sup>3</sup>	比容	Specific volume	v	m <sup>3</sup> /kg
风机转速	Fan Speed/ RPM	n	r/min(rpm)	圆周速度	Tip speed	u	m/s
压力	Pressure	p	Pa	媒介密度	Density of medium	ρ	kg/m <sup>3</sup>
气体常数	Gas constant	R	J/kgK	角速度	Angular velocity	ω	rad/s
半径	Radius	r	m(mm)	重力加速度	Gravitational speed acceleration	g	m/s <sup>2</sup>
绝对温度	Temperature in Kelvin	T	K	转动惯量	Moment of inertia	J	kg·m <sup>2</sup>
摄氏温度	Temperature in Celsius	t	°C	力	Force	F	N
功率	Power	P	W	质量	Weight	m	kg

### 2. 常用电机符号 Common Motor Symbols

名称	Designation	Symbol/符号	Unit/SI单位	名称	Designation	Symbol/符号	Unit/SI单位
额定电压	Rated voltage	U	v	电容	Capacitor	C400V	μF
额定电流	Rated current	I <sub>N</sub>	A	额定功率	Rated power	P <sub>N</sub>	W
电动机转速	Motor speed/ RPM	n <sub>d</sub>	r/min	供电频率	Power supply frequency	f <sub>1</sub>	Hz
额定转矩	Rated torque	T <sub>N</sub>	Nm	功率因数	Power factor	cos φ	-
临界转矩	Breakdown torque	T <sub>cr</sub>	Nm	电机效率	Motor efficiency	η <sub>m</sub>	-
启动转矩	Starting torque	T <sub>s</sub>	Nm	绝缘等级	Insulation class	B/F/H	-
负载转矩	Loaded torque	T <sub>l</sub>	Nm	防护等级	Protection grade	IP	-

### 3. 常用风机符号 Common Fan Symbols

名称	Designation	Symbol/符号	Unit/SI单位	名称	Designation	Symbol/符号	Unit/SI单位
体积流量	Volume capacity	q <sub>v</sub>	m <sup>3</sup> /h (m <sup>3</sup> /s)	A声压级	Sound pressure level A-weighted	L <sub>pA</sub>	dB(A)
质量流量	Mass capacity	q <sub>m</sub>	kg/s	入口A声压级	Inlet sound pressure level	L <sub>p1A</sub>	dB(A)
流速	Flow speed	c	m/s	出口A声压级	Outlet sound pressure level	L <sub>p0A</sub>	dB(A)
全压	Total pressure	P <sub>tF</sub>	Pa(in.wg)	A声功率级	Sound power level A-weighted	L <sub>wA</sub>	dB(A)
静压	Static pressure	P <sub>sF</sub>	Pa(in.wg)	环境声级	Surrounding sound power level	L <sub>w2A</sub>	dB(A)
动压	Dynamic pressure	P <sub>dF</sub>	Pa	入口A声功率级	Inlet sound power level	L <sub>w1A</sub>	dB(A)
静压差	Differential static pressure	ΔP <sub>sF</sub>	Pa	出口A声功率级	Outlet sound power level	L <sub>w0A</sub>	dB(A)
动压差	Differential dynamic pressure	ΔP <sub>dF</sub>	Pa	进出口噪声差值	Differential between inlet and outlet	ΔL <sub>wA</sub>	dB(A)
风机出口处动压	Dynamic pressure at fan outlet	P <sub>d2</sub>	Pa	叶轮圆周速度	Tip speed	u <sub>2</sub>	m/s
升压	Pressures rise	ΔP <sub>tF</sub>	Pa	允许最大媒介温度	Max. permissible medium temperature	t	°C
临界转速	Critical speed	n <sub>cr</sub>	r/min	运动粘性系数	Coefficient of kinematic viscosity	γ	m <sup>2</sup> /s
比转速	Specific speed	N <sub>s</sub>	r/min	叶轮平衡等级	Impeller balance grade	G	mm/s
管道长度	Duct length	l <sub>2</sub>	m	压缩性系数	Compressibility factor	Z	-
叶轮直径	Impeller diameter	D	m	效率	Efficiency	η	-
管径	Duct diameter	d <sub>g</sub>	m	机械效率	Mechanical efficiency	η <sub>me</sub>	-
流量系数	Volume coefficient	ψ	-	静压效率	Static efficiency	η <sub>sF</sub>	-
雷诺数	Reynolds number	Re	kW	全压效率	Total efficiency	η <sub>tF</sub>	-
轴功率	Shaft power	P <sub>sh</sub>	kW	阻力系数	Coefficient of resistance	ζ	-
电机输出功率	Motor output power	P <sub>o</sub>	kW	管道摩擦系数	Coefficient of friction of duct work	λ R	-

### 风机定律

该样本中风机性能均指在标准状态下的性能，即风机的气体状态为：

空气压力	Air pressure	P = 101.325 KPa
空气温度	Air temperature	t = 20 °C
空气密度	Air density	ρ = 1.2 Kg/m <sup>3</sup>

风机定律方程式：

Fan Laws Equations:

$$\frac{q_{v2}}{q_{v1}} = \frac{n_2}{n_1} \times \left(\frac{D_2}{D_1}\right)^3 \quad \frac{p_2}{p_1} = \left(\frac{n_2}{n_1}\right)^2 \times \left(\frac{D_2}{D_1}\right)^2 \times \left(\frac{\rho_2}{\rho_1}\right) \quad \frac{P_2}{P_1} = \left(\frac{n_2}{n_1}\right)^3 \times \left(\frac{D_2}{D_1}\right)^5 \times \left(\frac{\rho_2}{\rho_1}\right)$$

应用一：风机转速的变化。

Application 1: Change in Fan Speed.

a) 当风机尺寸、管网系统及空气密度都不变时，可得：

a) When the fan, the airflow system and the air density remain unchanged:

$$\frac{q_{v2}}{q_{v1}} = \frac{n_2}{n_1} \quad \frac{p_2}{p_1} = \left(\frac{n_2}{n_1}\right)^2 \quad \frac{P_2}{P_1} = \left(\frac{n_2}{n_1}\right)^3$$

★ 注：这个定理常用于解决现场风量过大或者风量不足的情况。

★ Note: This application is normally used to fix the airflow problems (too big or too small) at site.

例 1：某工程项目需要一台后向离心风机来送风，风量为 25000 m<sup>3</sup>/h，静压为 730 Pa。经选型，可得风机型号为 SYQ630R，转速为 1220 r/min，轴功率为 7.47 kW(电机功率为 11 kW)。现场要求风量大于原来设计风量，要求风量增加到 30000 m<sup>3</sup>/h。求风机新的转速，静压及轴功率。

E.g. 1: A project needs a backward inclined centrifugal fan to supply air, its airflow is 25,000 m<sup>3</sup>/h and the static pressure is 730 Pa. After selection, the fan is SYQ630R, the fan speed is 1220 r/min and the shaft power is 7.47 kW (the motor power is 11 kW). Now the site needs to increase the airflow to 30,000m<sup>3</sup>/h. Find the new fan speed, static pressure and the shaft power.

$$\frac{q_{v2}}{q_{v1}} = \frac{n_2}{n_1} \Rightarrow n_2 = \frac{30000}{25000} \times 1220 = 1464 \text{ r/min}$$

$$\frac{p_2}{p_1} = \left(\frac{n_2}{n_1}\right)^2 \Rightarrow p_2 = \left(\frac{1464}{1220}\right)^2 \times 730 = 1051 \text{ Pa}$$

$$\frac{P_2}{P_1} = \left(\frac{n_2}{n_1}\right)^3 \Rightarrow P_2 = \left(\frac{1464}{1220}\right)^3 \times 7.47 = 12.91 \text{ kW}$$

SYQ630R 风机的最高转速为 1700 r/min。当风机转速提高到 1464 r/min, SYQ630R 的风机能满足要求。当前风机的轴功率提高到 12.91 kW。原有的 11 kW 电机已不能满足要求，需更换电机。

The maximum fan speed of SYQ630R is 1700 r/min, so it is not a problem for the fan speed to run 1464 r/min. Now, the shaft power is increased to 12.91 kW, so the original 11 kW motor cannot be used, the motor needs to be changed.

★ 注意：当现场需要增加风量时，必须注意

- (1) 风机新的转速不能超过风机的最高转速。
- (2) 如原有的电机功率不能满足新的轴功率时，就需要更换电机。

例 2：在同样的情况下，客户要求增加风量，但不想再投资去更换电机，求此 11 kW 电机的条件下，允许增加多少转速？在这个新的转速下，风量和静压是多少？

解：11 kW 的电机功率减去 10% 的安全系数得轴功率为 9.9 kW。

$$\frac{P_2}{P_1} = \left(\frac{n_2}{n_1}\right)^3 \Rightarrow n_2 = \left(\frac{P_2}{P_1}\right)^{\frac{1}{3}} \times n_1 = \left(\frac{9.9}{11}\right)^{\frac{1}{3}} \times 1220 = 1340 \text{ r/min}$$

$$\frac{q_{v2}}{q_{v1}} = \frac{n_2}{n_1} \Rightarrow q_{v2} = \frac{1340}{1220} \times 25000 = 27460 \text{ m}^3/\text{h}$$

$$\frac{P_2}{P_1} = \left(\frac{n_2}{n_1}\right)^2 \Rightarrow p_2 = \left(\frac{1340}{1220}\right)^2 \times 730 = 881 \text{ Pa}$$

∴ 如果不更换电机的情况下，风量只能从 25000 m<sup>3</sup>/h 增加到 27460 m<sup>3</sup>/h。

应用二：气体密度的变化。

(a) 当风机尺寸，管网系统及风机转速都不变时，可得：

$$q_{v2} = q_{v1} \quad \frac{P_2}{P_1} = \frac{\rho_2}{\rho_1} \quad \frac{P_2}{P_1} = \frac{\rho_2}{\rho_1}$$

(b) 当风机尺寸，管网系统及压力都不变时，可得：

$$p_2 = p_1 \Rightarrow \left(\frac{n_2}{n_1}\right)^2 = \left(\frac{\rho_1}{\rho_2}\right) \Rightarrow \left(\frac{n_2}{n_1}\right) = \left(\frac{\rho_1}{\rho_2}\right)^{\frac{1}{2}} \quad \frac{q_{v2}}{q_{v1}} = \frac{n_2}{n_1} = \left(\frac{\rho_1}{\rho_2}\right)^{\frac{1}{2}}$$

$$\frac{P_2}{P_1} = \left(\frac{n_2}{n_1}\right)^3 \times \left(\frac{\rho_2}{\rho_1}\right) = \left(\frac{\rho_1}{\rho_2}\right)^{\frac{3}{2}} \times \left(\frac{\rho_2}{\rho_1}\right) = \left(\frac{\rho_1}{\rho_2}\right)^{\frac{1}{2}} \Rightarrow \frac{P_2}{P_1} = \frac{q_{v2}}{q_{v1}}$$

(c) 当风机尺寸，管网系统及空气质量流量 (q<sub>m</sub>) 都不变时，可得：

$$q_m = q_v \times \rho \quad q_{m2} = q_{m1} \Rightarrow q_{v2} \times \rho_2 = q_{v1} \times \rho_1$$

$$\frac{q_{v2}}{q_{v1}} = \frac{\rho_1}{\rho_2} \quad \frac{n_2}{n_1} = \frac{\rho_1}{\rho_2} \quad \frac{P_2}{P_1} = \frac{\rho_1}{\rho_2} \quad \frac{P_2}{P_1} = \left(\frac{\rho_1}{\rho_2}\right)^2$$

★ 注：风机样本中的风机性能曲线都是以标准空气为基础的，这个定理是用于高海拔高度或高温度的情况，空气密度有变化时，选择风机的基础。

★ NOTE: When the customer site needs to increase the airflow, please pay attention

- (1) The new fan speed cannot exceed the maximum fan speed.
- (2) If the original motor cannot meet requirement of the new shaft power, then the motor needs to be replaced.

E.g. 2: In the same case, the client requests for additional airflow, but do not want to invest to replace the motor. Under the same 11 kW motor conditions, what is the new fan speed? And in this new speed, what is the airflow and static pressure?

If the safety factor is 10%, the shaft power will be 9.9 kW.

If the motor is not replaced, then the airflow can only be increased from 25000 m<sup>3</sup>/h to 27460 m<sup>3</sup>/h.

Application 2: Change in Air Density.

(a) When the fan size, the airflow system and the fan speed remain unchanged:

(b) When the fan, the airflow system and the pressure remain unchanged:

(c) When the fan, the airflow system and the mass flow rate (q<sub>m</sub>) remain unchanged:

★ Note: The fan performance curves in the catalog are measured under the standard air condition. This application is used for the selection of the fans that running in the high altitude or in the high temperature condition, when there is a change in the air density.

例 3: 某工厂需要一台风机用于排除一个锅炉产生的 20000 m<sup>3</sup>/h 的 120℃ 的高温气体，其静压为 450 Pa。求风机所需的轴功率。

解：120℃ 的空气密度 = 0.9 kg/m<sup>3</sup>  
标准空气的密度 = 1.2 kg/m<sup>3</sup>

$$q_{v2} = q_{v1} = 20000 \text{ m}^3/\text{h}$$

20000 m<sup>3</sup>/h 风量及静压 600 Pa，标准空气工况选型，得风机 SYQS900E。转速为 770 r/min，轴功率为 4.93 kW (电机为 5.5 kW)。

当用于 120℃ 的高温空气，

$$p_2 = \frac{0.9}{1.2} \times 4.93 = 3.7 \text{ kW}$$

∴ 所需轴功率为 3.7 kW。

应用三：风机尺寸的变化。

(a) 当风机转速及空气密度都不变时，可得：

$$\frac{q_{v2}}{q_{v1}} = \left(\frac{D_2}{D_1}\right)^3 \quad \frac{P_2}{P_1} = \left(\frac{D_2}{D_1}\right)^2 \quad \frac{P_2}{P_1} = \left(\frac{D_2}{D_1}\right)^5$$

(b) 当风机的轮缘线速度及气体密度都不变时，可得：

$$u_2 = u_1 \quad n_2 D_2 = n_1 D_1 \quad \therefore \frac{n_2}{n_1} = \frac{D_1}{D_2} \Rightarrow \frac{q_{v2}}{q_{v1}} = \left(\frac{D_2}{D_1}\right)^2 \quad p_2 = p_1 \quad \frac{P_2}{P_1} = \left(\frac{D_2}{D_1}\right)^2 = \frac{q_{v2}}{q_{v1}}$$

★ 注：这个定理一般为风机设计人员所用，很少用于现场。

例 4：一家风机制造厂商想把直径为 355 mm 风机的性能数据扩大应用于直径为 710 mm 的风机。355 mm 风机在风量 8000 m<sup>3</sup>/h，静压为 300 Pa 时，它的转速为 784 r/min，轴功率为 1.33 kW。轮缘线速度为 14.57 m/s。对应一个 710 mm 风机，在相同的转速 (784 r/min) 时，求它对应的风量，静压，轴功率及轮缘线速度。

$$\frac{q_{v2}}{q_{v1}} = \left(\frac{D_2}{D_1}\right)^3 \quad q_{v2} = \left(\frac{710}{355}\right)^3 \times 8000 = 64000 \text{ m}^3/\text{h}$$

$$\frac{P_2}{P_1} = \left(\frac{D_2}{D_1}\right)^5 \quad P_2 = \left(\frac{710}{355}\right)^5 \times 1.33 = 42.56 \text{ kW}$$

E.g. 3: A factory needs a fan to draw high temperature air from an oven which is delivering 20,000 m<sup>3</sup>/h of 120 °C air against 450 Pa static pressure. Find the shaft power required for the fan.

The air density at 120 °C = 0.9 kg/m<sup>3</sup>  
The standard air density = 1.2 kg/m<sup>3</sup>

$$p_2 = \frac{1.2}{0.9} \times 450 = 600 \text{ Pa}$$

Using the airflow 20,000 m<sup>3</sup>/h and the static pressure 600 Pa, under the standard air condition, the fan selected is SYQS 900E, the fan speed is 770 r/min, the shaft power is 4.93 kW (motor is 5.5 kW).

When running at 120 °C high temperature air,

$$p_2 = \frac{0.9}{1.2} \times 4.93 = 3.7 \text{ kW}$$

The shaft power required is 3.7 kW.

Application 3: Change in Fan Size.

(a) When the fan speed and the air density remain unchanged:

(b) When the tip-speed of fan and the air density remain unchanged:

E.g. 4: A fan manufacturer wishes to project data obtained for a 355 mm fan to a 710 mm fan. At one operating point, the airflow is 8000 m<sup>3</sup>/h and the static pressure is 300 Pa, the fan speed of the 400 mm fan is 784 r/min, the shaft power is 1.33 kW and its tip-speed is 14.57 m/s.

What will the projected airflow, static pressure, shaft power and tip-speed be for a 710 mm fan at the same fan speed (784 r/min)?

$$\frac{P_2}{P_1} = \left(\frac{D_2}{D_1}\right)^2 \quad p_2 = \left(\frac{710}{355}\right)^2 \times 300 = 1200 \text{ Pa}$$

$$\frac{u_2}{u_1} = \frac{D_2}{D_1} \quad u_2 = \left(\frac{710}{355}\right) \times 14.57 = 29.14 \text{ m/s}$$

风机性能曲线

Fan Performance Curves

由于不同类型和不同尺寸的风机各有特点，风机制造商必须制定风机性能曲线。风机性能曲线是风机运转的图形表示，通常它包括从自由输送(即无阻碍的气流)到无输送(即气流完全被密封的系统)的全部范围，气体的流量 $q_v$ 可由以下一个或多个参数表示：

- 静压  $p_{sF}$
- 全压  $p_{tF}$
- 功率  $P$
- 风机静效率  $\eta_{sF}$
- 风机全压效率  $\eta_{tF}$

气体密度( $\rho$ )、风机尺寸，以及转速( $n$ )。通常在曲线中称为常量，并应加以标注。

一个典型的风机性能曲线如图2)。这些曲线一般均按照适当的工业测试标准进行实验室试验。例如国际空气运动与控制协会 (AMCA International)。风机定律用于在其他速度和风机尺寸时测定轴功率和性能特点，通常情况下，就如之前提到的，只需测试一个型号风机的尺寸和速度，就能确定该系列风机的效能。

Since each type and size of fan has different characteristics, fan performance curve must be developed by the fan manufacturers.

A fan performance curve is a graphical presentation of the performance of a fan. Usually it covers the entire range from free delivery (no obstruction to flow) to no delivery (an air tight system with no air flowing). One or more of the following characteristics may be plotted against volume flow rate ( $q_v$ ).

- Statics Pressure  $p_{sF}$
- Total Pressure  $p_{tF}$
- Power  $P$
- Fan Static Efficiency  $\eta_{sF}$
- Fan Total Efficiency  $\eta_{tF}$

Air density( $\rho$ ), fan size, and fan speed( $n$ ) are usually constant for the entire curve and must be stated.

A typical fan performance curve is shown in Fig.2. Generally, these curves are determined by laboratory tests, conducted according to an appropriate industry test standard, e.g. Air Movement and Control Association International Inc.(AMCA). The "Fan Laws" are used to determine the brake horsepower and performance characteristics at other speeds and fan sizes. Normally, as mentioned before, only one fan size and speed must be tested to determine the capacity for a given "family" of fans.

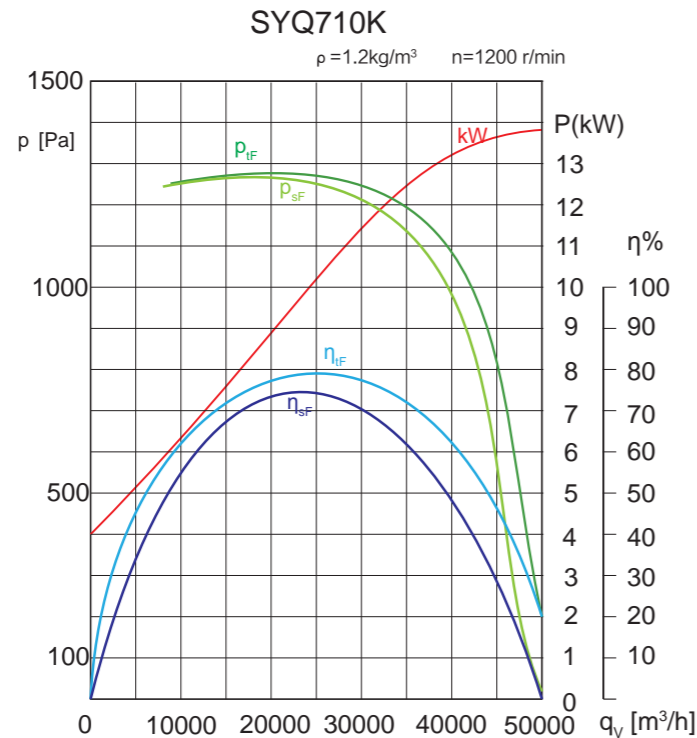

Fig.2 Fan Performance Curve

图2 风机性能曲线图

系统阻力曲线

System Resistance Curve

1) 管网系统的阻力是指过滤器、冷热盘管、挡板、风阀及管道等所有压力损失的总和。系统阻力曲线(如图3)仅绘出气体通过系统所需的压力。

1) System resistance is the total sum of all pressure losses through filters, coils, dampers, and duct work. The system resistance curve (Fig.3) is simply a plot of the pressure that is required to move the air through the system.



图3 系统阻力曲线

Fig.3 System Resistance Curve

$$\frac{P_{sF2}}{P_{sF1}} = \left(\frac{q_{v2}}{q_{v1}}\right)^2 = \left(\frac{2000}{1000}\right)^2 = \frac{4}{1}$$

2) 管网系统的阻力方程：

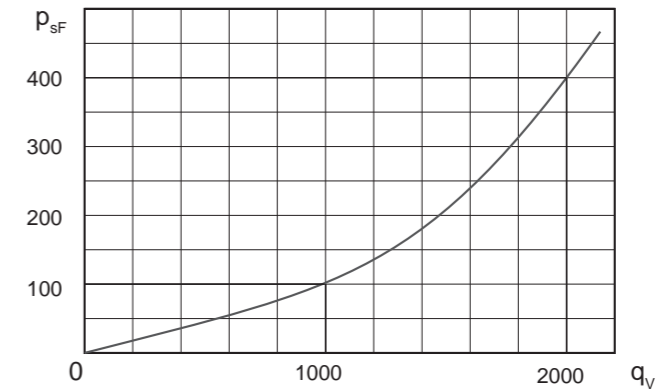
2) The pressure equation of a airflow system is:

$$p = k(q_v)^2$$

管网系统所需的功率公式：

The power required for the air moving through the airflow system is:

$$P = \frac{q_v \times p}{3600 \times 1000}$$

3) 例如，考虑一个  $1000 m^3/h$  的系统，阻力总和为  $100 Pa$ 。如果  $q_v$  加倍， $p_{sF}$  静压阻力则将增至  $400 Pa$ ，如图 3 中比例的平方值所示。

3) For example, consider a system handling  $1000 m^3/h$  with a total resistance of  $100 Pa$  SP. If the  $q_v$  is doubled, the SP resistance will increase to  $400 Pa$ , as shown by the squared value of the ratio given in Fig.3.

4) 但是当过滤器滤有污物，盘管开始凝结水分，或出口调节板改变了位置时，这曲线就会有变化。

4) This curve changes, however, as filters load with dirt, coils start condensing moisture, or when outlet dampers change in position.

5) 工况点：图 4 所示的风机在系统中运行的工况点，是由系统阻力曲线和风机转速性能曲线相交点来确定。每个风机只按它的性能曲线操作，如果原设计系统阻力与安装时的阻力不同，工况点将会变化，静压和输送风量将与计算不同。

5) Operating point: The operating point (Fig.4) at which the fan and system will perform is determined by the intersection of the system resistance curve and fan performance curve. Note that every fan operates only along its performance curve. If the system resistance designed is not the same as the resistance in the system installed, the operating point will change and the static pressure and volume delivers will not be as calculated.





图4 工况点

Fig.4 Operating Point

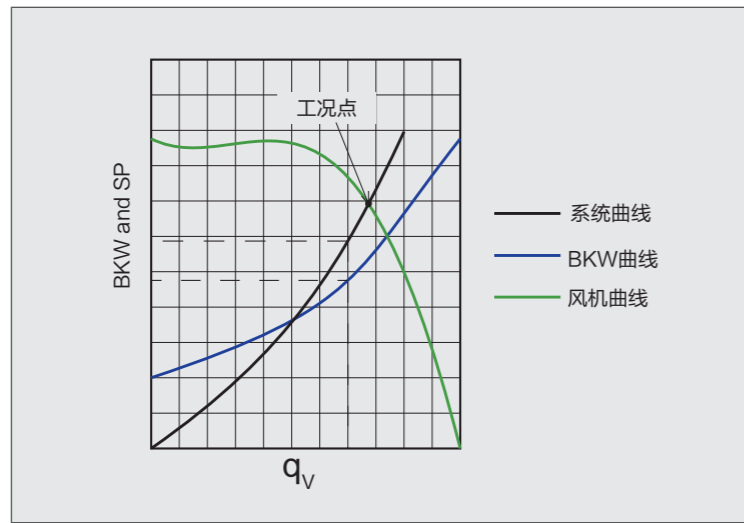

图5 系统阻力曲线的变化——风量减少

Fig.5 Change In System Resistance Curve——Air Volume Reduced

6) 如果实际系统比预先设计的有更多的阻力损失，因而气体流量减少，静压增加。(如图 5) 功率曲线的形状显示轴功率减少。

6) If the actual system has more pressure lose than predicted in the design. Such, air volume is reduced and static pressure is increased. (Fig.5) The shape of the kW curve typically would result in a reduction in BKW.

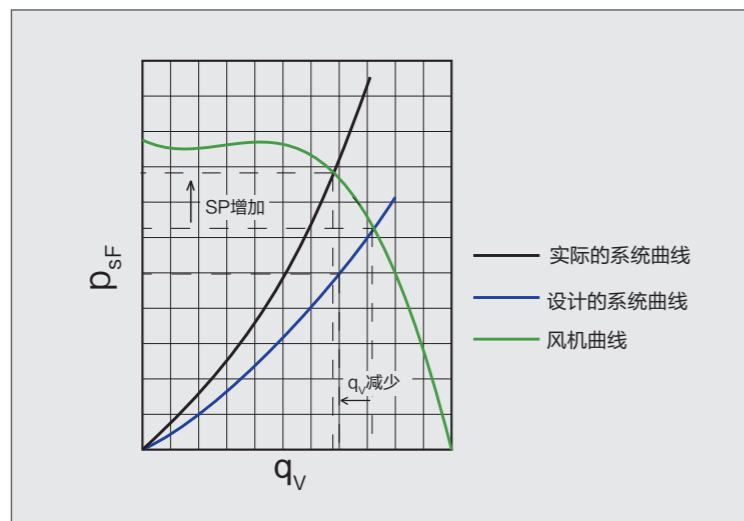
7) 在很多情况下，风机的实际输出与计算输出之间有差别，它是由于系统阻力的变化而不是风机或电机的原因。通常是在错误的交点上获得了静压值，并认为当静压高于设计值时，Q 也会高于设计值，图 5 显示为何这种假设完全错误的。

7) In many cases where there is a difference between actual and calculated fan output, it is due to change in system resistance rather than any shortcomings of the fan or motor. Frequently the mistake is made when taking the static pressure reading across the fan and concluding that if the static pressure is at or above design requirements the volume is also at or above design requirements. Fig.5 shows why the assumption is completely invalid.

## 风机振动

不平衡的风机在运转时会引起振动，这种振动反过来又会使轴承、轴套等产生过度的磨损，大大降低他们的使用寿命。振动又会在支座及支架中造成非常不利的交替应力。并最终将其完全破坏，而且机器的性能也会由于功率被支撑结构吸收而降低。此外，振动还可以通过地板传递到邻近的机器，严重地影响它们的精度和正常的功能。

## Fan Vibration

Unbalanced fan can cause vibration during operation. This vibration in turn may cause excessive wear in shafts, bearings, bushings, etc., and greatly reduce their service lives. The vibration will then create a very negative alternating stress in structural supports and frames which may eventually lead to their complete destroy. And the fan's performance will decrease due to the power absorbed by the supporting structure. In addition, the vibration can also be transmitted through the floor to the nearby machines, which can seriously affect their accuracy and proper function.

引起风机振动的原因有很多种的，常见的情况如下：

The fan vibration is caused by a variety of reasons, the commons are as follows:

- (a) 转子(如风机叶轮、轴或皮带轮等)不平衡
- (b) 联轴器不对中
- (c) 基础、支座、支架等刚度不够
- (d) 风机进口处及出口处的气流不均匀
- (e) 轴承的润滑油不够等等

- (a) The unbalanced rotor (eg: fan impeller, shaft, pulley etc.).
- (b) The coupling is misaligned.
- (c) The rigidity of the foundation, structural support, frame is not enough.
- (d) The uneven airflow passing through the inlet or the outlet of the fan.
- (e) Insufficient lubrication of the bearings, and so on.

其中，引起风机振动最大的原因是转子的动不平衡造成的。

The main cause of the fan vibration is the unbalanced rotor.

## 风机的平衡

风机经过动平衡校验的作用是：

## Fan Balancing

The effects of the fan trim balancing are:

- (a) 提高风机的性能
- (b) 减小振动
- (c) 减小噪声
- (d) 提高轴承的使用寿命
- (e) 减少对使用者的干扰及疲劳
- (f) 减少能源的损失

- (a) To improve the fan performance
- (b) To reduce the vibration
- (c) To reduce the noise
- (d) To improve the lifetime of the bearings
- (e) To reduce the fatigue and the disturbance of the operators
- (f) To reduce the energy losses

## 转子的平衡质量等级

考虑到技术的先进性和经济上的合理性，国际标准化组织 (ISO) 于 1940 年制定了世界公认的 ISO 1940 平衡质量等级。它将转子平衡质量等级分为 11 个级别，每个等级之间以 2.5 倍为增量，平衡机从要求最高的 G0.4 到要求最低的 G4000。每个等级的单位为 mm/s。

## Balance Quality Grades for Rotors

Taking into account the advanced technology and economic rationality, in year 1940, the International Organization for Standardization (ISO) have formulated the Balance Quality Grades for Rotors. The Balance Quality Grades for Rotors is divided into 11 grades, each grade is increased by 2.5 times. The balancing machine is requested to balance from the highest grade G0.4 to the lowest grade G4000. The unit of the grade is mm/s.



表 1- 转子的平衡质量等级

Table 1 - Guidance for balance quality grades for rotors in a constant (rigid) state

转子类型举例 Machinery types: General examples	平衡精度 Balance quality grade G	振幅 Magnitude $e_{per} \cdot \Omega$ mm/s
刚性安装的船用柴油机的曲轴驱动件；刚性安装的大型四冲程发动机的曲轴驱动件。 Crankshaft drives of marine diesel engine with rigid installation; Crankshaft drives of large-scale four-stroke engine with rigid installation.	G630	630
刚性安装的高速四缸柴油机的曲轴驱动件。 Crankshaft drives of high-speed four-stroke diesel engine with rigid installation.	G250	250
六缸和多缸柴油机的曲轴驱动件；汽车、货车和机车用的（汽油、柴油）发动机整机。 Crankshaft drives of 6-stroke or multiple-stroke diesel engine. Complete reciprocating engines for cars, trucks and locomotives(gasoline, diesel oil).	G100	100
汽车车轮、箍轮、车轮整体； 汽车、货车和机车用的发动机的曲轴驱动件。 Cars: wheels, wheel rims, wheel sets, drive shafts; Crankshaft drives of the cars, trucks and locomotives motor.	G 40	40
粉碎机、农业机械的零件； 汽车、货车和机车用的（汽油、柴油）发动机个别零件。 Components of crushing machines and agricultural machinery; Motor individual component of cars, truck and locomotive(gasoline, diesel oil).	G 16	16
海轮（商船）主蜗轮机的齿轮； 离心分离机、泵的叶轮； 风扇； 航空燃气涡轮机的转子部件； 飞轮； 机床的一般零件； 普通电机转子； 特殊要求的发动机的个别零件。 Main turbine gear of seacraft(merchantman); Centrifugal machine, pump impeller; Fans; Rotors of Aircraft gas turbines; Flywheel; General component of machine-tools; General motor rotor; Individual component of special requirement motor.	G 6.3	6.3

燃气和蒸汽涡轮，包括海轮（商船）主涡轮刚性涡轮发电机转子； 透平增压器； 机床驱动件； 特殊要求的中型和大型电机转子； 小电机转子； 涡轮泵。 Gas and steam turbine, including ri motor rotor of rigid turbine; Turbo-chargers; Mechine tool actuator; Midsize and large size motor rotor with special requirement; Minitype motor rotor; Turbine pump.	G 2.5	2.5
磁带录音机及电唱机驱动件； 磨床驱动件； 特殊要求的小型电枢。 Audio and video drives; Grinding machine drives; Minitype drives with special requirement.	G 1	1
精密磨床的主轴、磨轮及电枢、回转仪。 Spindles and drives of high-precision grinder; drives and gyroscopes.	G 0.4	0.4
<p>注1：通常的大部分组长完成的转子是分类的，根据特定的用途，高一个的等级或低一个的等级能用来替换，对于组件，请参阅第九条。</p> <p>注2：在不指明或不言自明（如曲轴驱动件）的情况下，所有转子都是运转的。</p> <p>注3：对于因设置条件（平衡机、模具）的限制，请参见5.2中的注4和注5。</p> <p>注4：对于所选的平衡质量等级的其他信息，请参阅图2。基于经验，其包含了普遍的使用范围（使用速度和平衡质量等级G）</p> <p>注5：曲轴的驱动器可能包括曲轴，飞轮，离合器，减震器，旋转连杆的部分。原有的不平衡曲轴驱动器理论上可以不平衡；固有的平衡曲轴驱动器理论上可以平衡。</p> <p>注6：对于某些机器，可能存在具体说明平衡公差的国际标准（见参考书目）。</p> <p>NOTE 1 Typically completely assembled rotors are classified here. Depending on the particular application, the next higher or lower grade may be used instead. For components, see Clause 9.</p> <p>NOTE 2 All items are rotating if not otherwise mentioned (reciprocating) or self-evident (e.g. crankshaft drives).</p> <p>NOTE 3 For limitations due to set-up conditions (balancing machine, tooling), see Notes 4 and 5 in 5.2.</p> <p>NOTE 4 For some additional information on the chosen balance quality grade, see Figure 2. It contains generally used areas (service speed and balance quality grade G), based on common experience.</p> <p>NOTE 5 Crankshaft drives may include crankshaft, flywheel, clutch, vibration damper, rotating portion of connecting rod. Inherently unbalanced crankshaft drives theoretically cannot be balanced; inherently balanced crankshaft drives theoretically can be balanced.</p> <p>NOTE 6 For some machines, specific International Standards stating balance tolerances may exist (see Bibliography).</p>		

从表中,ISO 建议风机的平衡质量等级为 G6.3。  
但亿利达为了使风机的性能更好,寿命更长久,所以,亿利达的风机将内控的平衡等级定位 G2.5。

In the table, the ISO suggested that the balance quality grade for the fans is G6.3.  
However, in order to have a better performance and a longer lifetime of the fans, YILIDA has balanced all the fans to a higher grade G2.5.

## 平衡机的作用

为了测不平衡量并确定其位置,平衡机是必要的。平衡机所测出的数据可用来改变转子的质量分布。当测量准确时,它可以使转子达到平衡。

## The Purpose of Balancing Machine

A balancing machine is necessary to detect, measure and determine the location of unbalance. The data measured by the balancing machine can be used to change the mass distribution of a rotor. When measuring is done accurately, it can balance the rotor.

## 允许的剩余不平衡量

由于任何转子不可能做到 100% 的平衡,因此必须有一些不平衡的余量。

一个圆轮的半径为 R(mm),重量为 M(kg),在圆轮上有一超重点 m(g)。当圆轮旋转时,有一离心力 F 作用在 m 上,并且传递到圆轮的轴上。结果,轴中心由原来的静止位置产生位移,并围绕其原来位置形成一个很小的圆。  
这个位移称为偏心率,见下图

## Permissible Residual Unbalance

Since it is not possible to have 100% balancing, so there must be some unbalance in tolerance.

A wheel with radius R (mm) and weight M (kg), has a little overweight m (g) at a point. When the wheel is rotating, a centrifugal force F acts upon m and is transmitted to the centre axis. As the result, the axis is displaced from its original position and rotate around its original position to form a small circle. This displacement is called the eccentricity. See below

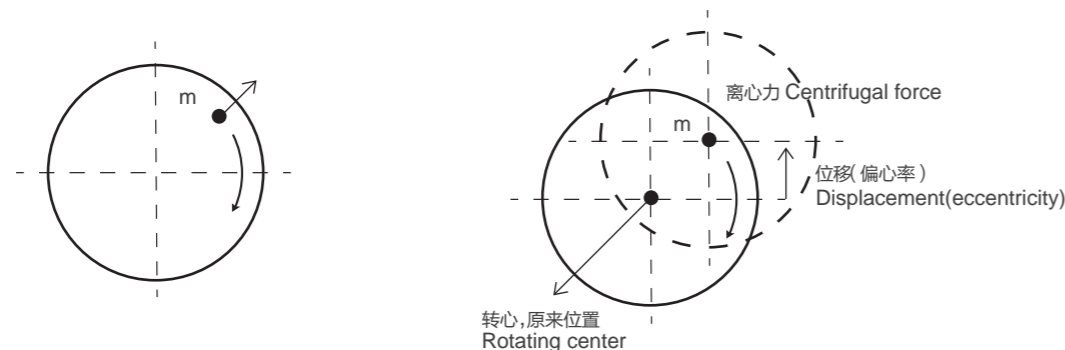

这偏心率  $e_{per}$  用下列公式表示它与圆轮重量  $m$  (kg), 半径  $R$  (mm) 及超重点  $m$  (g) 的关系:

$$e_{per} = \frac{m \times R}{M} \text{ (g.mm / kg) 或 } (\mu\text{m})$$

$e_{per}$  也表示为剩余不平衡量。

This eccentricity  $e_{per}$  is expressed its relationship with the wheel of weight  $M$  (kg), radius  $R$  (mm) and over weight point  $m$  (g) by the formula below:

$e_{per}$  is also called the residual unbalance.

国际标准化组织 (ISO) 以下列公式:

$$e_{per} = \frac{1000 \times G}{\omega} = \frac{60 \times 1000 G}{2\pi n} \approx \frac{9550 \times G}{n} \text{ (g.mm / kg) 或 } (\mu\text{m})$$

来表示最大剩余不平衡量  $e_{per}$  (g.mm/kg) 与平衡质量等级  $G$  (mm/s) 及转速  $n$  (r/min) 之间的关系(见表 2)。

The International Organization for Standardization (ISO) uses the following formula:

To express the relationship about the maximum residual unbalance  $e_{per}$  (g.mm/kg), the balance quality grades  $G$  (mm/s) and the rotation speed  $n$  (r/min). (Table 2)

例 1: SYT10-10L(DK) 风机的叶轮,最高转速为 1800 r/min,现要求平衡质量等级为 G2.5,求它的允许剩余不平衡量和校正平面上剩余不平衡值。

E.g. 1: The fan SYT10-10L(DK) impeller, and the fan's top speed is 1800 r/min. If it is required to balance to Balance quality Grade G2.5, find the permissible residual unbalance.

(1) 求允许剩余不平衡量:

$$e_{per} = \frac{9550 \times G}{n} = \frac{9550 \times 2.5}{1800} = 13.26 \mu\text{m}$$

SYT10-10L 叶轮质量为 3.231kg,平衡轴质量为 4.446 kg,合计为 7.677 kg。

(1) The permissible residual unbalance:

The mass of SYT10-10L fan impeller is 3.23kg; The mass of balance shaft is 4.446kg. Add up to 7.677kg.

$$\bar{U} = e \times M = 13.26 (\mu\text{m}) \times 7.677 (\text{kg}) = 101.8 \text{ g.mm}$$

(2) 求校正平面上剩余不平衡值:

因为 SYT10-10L 为双进风离心风机,需要校正左右两个平面的半径。

(2) The residual unbalance of correcting plane:

Cause SYT10-10L is the double-inlet centrifugal fan, so it needs to check the radiuses of the right and left plane.

$$m = \frac{\bar{U}}{2r} = \frac{e \times M}{2r} = \frac{13.26 (\mu\text{m}) \times 7.677 (\text{kg})}{2 \times 141 (\text{mm})} = 0.361 \text{ g} = 361 \text{ mg}$$

## 亿利达的风机的平衡

亿利达为了保证使风机的运行更稳定,性能更好,寿命更长久,所以,亿利达的每一个风机都经过三道的平衡,每一次的平衡都达到 ISO 平衡质量等级的 G2.5。  
亿利达风机的三道平衡如下:

## The Balancing of the Yilida Fans

In order to ensure that all the fans are running with good performance and long lifetime, Yilida ensures that all its fans are going through 3 types of balancing, each type of balancing has reached the ISO Balance Quality Grades of G2.5.  
The three types of balance are as follows:

ISO 1940-1:2003(E)

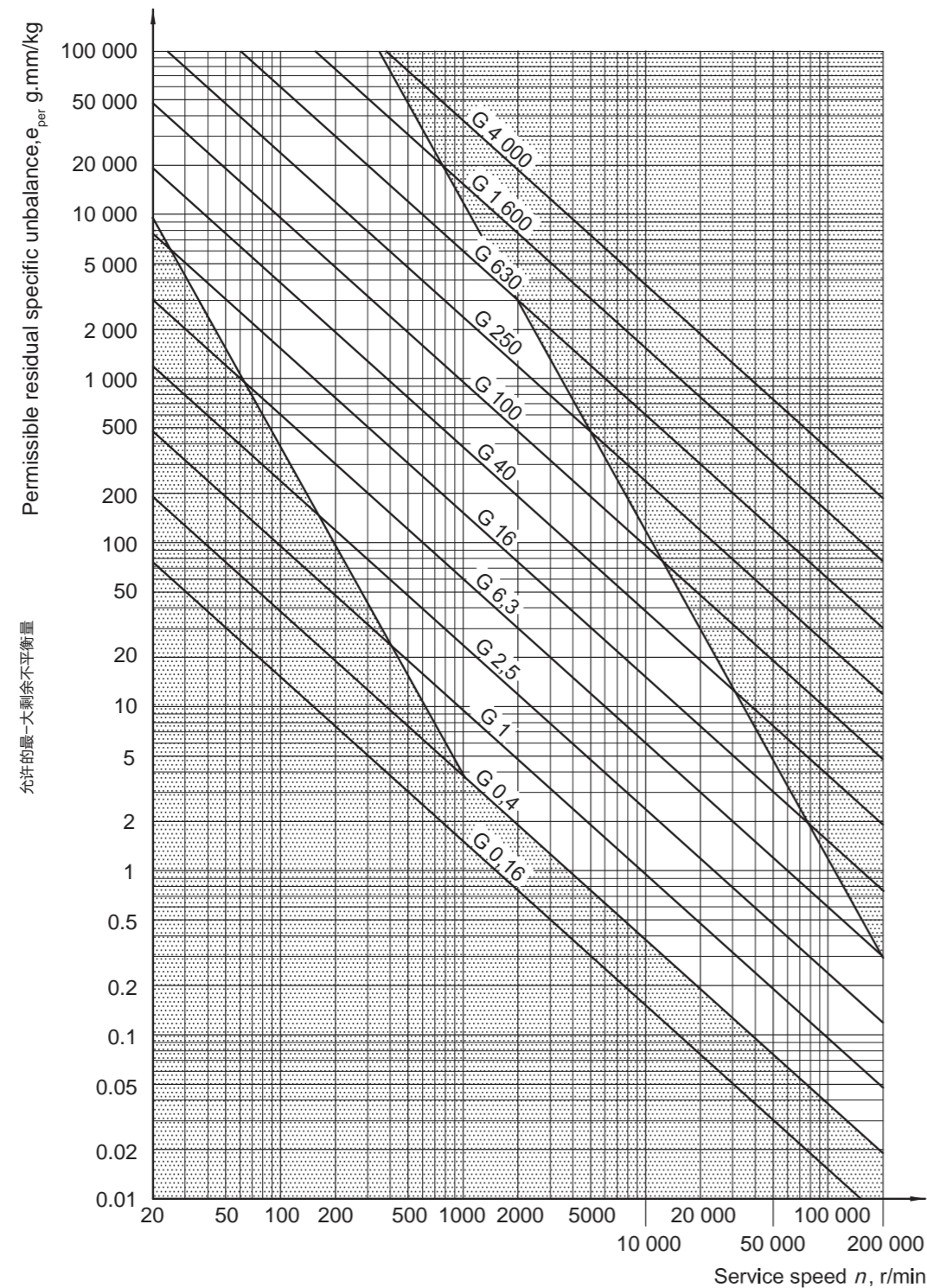

NOTE The white area is the generally used area, based on common experience.

Figure 2-Permissible residual specific unbalance based on balance quality grade G and service speed  $n$  (see 6.2)

(a) 风机叶轮的平衡

亿利达生产的每一个叶轮都要做动、静平衡,使每个叶轮在组装前达到 G2.5 的平衡等级。

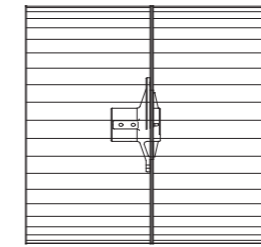

(a) Fan Wheel Balancing

Every wheel that manufactured by Yilida has to do the dynamic and static balance, so that each wheel is balanced to G2.5 before assembly.

(b) 风机的平衡

叶轮、轴、轴承、蜗壳及支架等等组装风机后,每个组装好的风机再做一次平衡,达到 G2.5 的平衡等级。

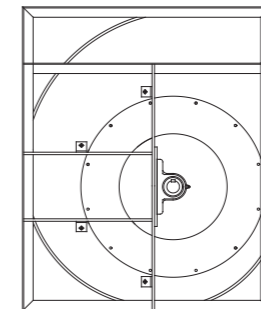

(b) Bare Fan Balancing

After assembly, the bare fan has to go through the balancing again, to reach G2.5 balance grade.

(c) 整机的平衡

风机、皮带轮、皮带、电机、底座及减振器等等组装成整机后,做最后的平衡,达到 G2.5 的平衡等级。平衡后的风机,电机等在运行时能更稳定。

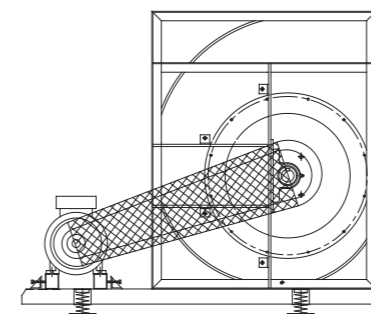

(c) Complete Fan Balancing

The bare fan, motor, pulleys, base frame, the isolators are assembled together to have a complete fan. The complete fan has to go through the last balance to reach G2.5 balance grade. After balancing that the fan,motor etc will be running more stable.

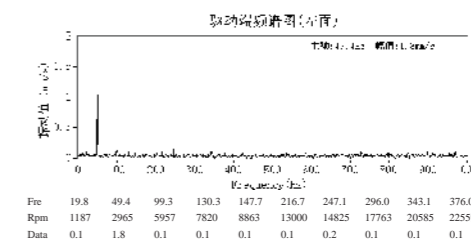



## 一、概述

声音的本质是波动。受作用的空气发生振动，当震动频率在20~20000Hz时，作用于人的耳鼓膜而产生的感觉称为声音。声源可以是固体、也可以是流体（液体和气体）的振动。下面介绍几个声音相关的物理量。

### 1) 声功率级

任何一个声源在运转时都会向外辐射声能，在稳定工况下单位时间内辐射的声能称为声功率W，以瓦（W）为单位。通常声学上以声功率级表示，即

$$L_w = 10 \lg \frac{W}{W_0}$$

式中  $L_w$ ——声功率级，单位为dB；  
 $W_0$ ——基准声功率， $W_0=10^{-12}W$ ；  
 $W$ ——声功率，单位为W。

### 2) 声强级和声压级

声源的声功率无法直接测定，而使通过测定声源的声压或声强后计算出声功率。声压P或声强I同样以声压级 $L_p$ 或声强级 $L_I$ 表示，即

$$L_p = 20 \lg \frac{P}{P_0}$$

式中  $L_p$ ——声压级，单位为dB；  
 $p$ ——声压，单位为Pa；  
 $p_0$ ——基准声压， $p_0=2 \times 10^{-5}Pa$ ；该值是对1000Hz的声音人耳刚能听到的最低声级

$$L_I = 10 \lg \frac{I}{I_0}$$

式中  $L_I$ ——声强级，单位为dB；  
 $I$ ——声强，单位为 $W/m^2$ ；  
 $I_0$ ——基准声强， $I_0=10^{-12}W/m^2$ 。对于1000Hz的声音，人耳能感觉到的最小声强约为 $10^{-12} W/m^2$ ，该基准声强为人的听阈。对于正常人的听觉所能忍受的声强为 $I_{max}=1 W/m^2$ ，称为痛阈。

### 3) 倍频程与声音频谱特性

人类能听到的声音一般指频率为20~20000Hz范围内的声波。为了测量方便，往往将这个频率范围划分成若干个小的频带或频段。在噪声测量中最常用的是倍频程和1/3倍频程。倍频程是指两个相邻频率之比为2:1确定的频段，国际IEC规格规定的常用倍频程如表1所示。1/3倍频程就是将一个倍频程再划分为三段。

频谱为声压级或声功率级随着频率的变化的图形，通风机噪声可以粗略地分为三类：频谱中最高声压级的中心频率低于500Hz的为低频噪声，最高声压级的中心频率在500~1000Hz为中频噪声，最高声压级的中心频率大于1000Hz为高频噪声。通风机的频谱一般用频谱分析仪测量得到。

表1

频程号 Octave number	1	2	3	4	5	6	7	8	
中心频率 center frequency/Hz	63	125	250	500	1000	2000	4000	8000	
频率范围 frequency coverage/Hz	45	90	180	355	710	1400	2800	5600	11200

## Outlines

The sound is a travelling oscillation. The sound that the human can hear is within the frequency range from 20 Hz to 20,000 Hz. Sound source can be from the vibration of the solid or fluid (liquid and gas).

### 1) Sound Power Level

The sound power is the sound energy radiated constantly from a sound source. Sound power is expressed in watts (W). Sound power converted to the decibel scale is called sound power level ( $L_w$ ).

where  $L_w$ ——sound power level, dB  
 $W_0$ ——reference sound power, W  
 $W$ ——sound power, W

### 2) Sound Intensity Level and Sound Pressure Level

The sound power from the sound source cannot be directly measured. The sound power is calculated from the sound pressure or the sound intensity that measured from the sound source. Similarly, sound pressure level and sound intensity level are expressed as below:

where  $L_p$ ——sound pressure level, dB  
 $p$ ——sound pressure, Pa  
 $p_0$ ——reference sound pressure,  $p_0=2 \times 10^{-5} Pa$ ,

This value is the minimum sound level at 1,000 Hz that the human ear can hear.

where  $L_I$ ——sound intensity level, dB  
 $I$ ——sound intensity,  $W/m^2$   
 $I_0$ ——reference sound intensity.

This value is the minimum sound intensity that the human ear can feel, and is the human hearing threshold. The maximum sound intensity that the human ear can tolerate is  $I_{max} = 1 W/m^2$ , it is known as the pain threshold.

### 3) Octave Bands and Sound Spectrum Characteristics

Normally, human can hear sounds within frequency range from 20 Hz to 20,000 Hz. For the convenient measuring, this frequency range is divided into several small octave bands. The most commonly used in sound measurement is the octave bands and 1/3 octave bands. An octave band is the frequency interval between two sounds whose ratio is 2. Table 1 shown the octave bands from the IEC Standard. 1/3 octave band is an octave band that divided into three portions. Spectrum is the graphics that the sound pressure level or the sound power level changes with the frequency. The sound from a fan can be roughly divided into three categories:

- The maximum sound pressure level of the center frequency of the band below 500 Hz is called low-frequency noise.
- The maximum sound pressure level of the center frequency of the band within 500 Hz to 1,000 Hz is called medium frequency noise.
- The maximum sound pressure level of the center frequency of the band greater than 1,000 Hz is called high frequency noise.

## 二、声音的测试方法

声压级和声强级可以用声级计或声强仪进行测定。声级计是常用的测量仪器，声强仪的使用目前尚未普及。

除了以上三个衡量声音的基本参数之外，还需要了解声音的频率成分，这就需要对声音进行频谱分析。常用的声音频谱为倍频程频谱和1/3倍频程频谱。声音频谱由精密声级计或专用的频率分析仪测定。通过声音频谱的测定，可以分析声源的频率成分，对其采取相应的降噪措施，使之减少向外辐射的声功率级。

声功率虽然可以由测定声压级的方法间接求得。但是，声压级测定时往往受到测试环境的影响而不易准确得出，为了使测试环境的影响降低至最小程度，创造了两种接近理想状态的实验室测试方法：自由声场法和混响声场法。

声源在一个特定空间内运行时，它所辐射的声能全部为边界所吸收而没有反射，在这个空间内形成特定的声波传播规律。这个特定空间称之为自由声场。模拟自由声场的实验室常用的是全消声室或半消声室。反之，若这个特定空间的边界是全反射而无声能的吸收，同样在此特定空间内也存在特定的声波传播规律。这个特定空间称之为混响声场，模拟混响声场的实验室常用的是混响室。

这里主要介绍下混响室法。

如果在以封闭的空室（混响室）内设置以声源，经过一段时间后，在该室内产生一恒定的声压级。

在切断声源后，声音并不立即消失，储存在空间的声能逐渐衰减，这一过程为扩散声场或混响声场。混响时间定义为声能密度衰减到60dB（即原有值的 $10^{-6}$ 倍）所需的时间。

在混响室中，测量充分扩散的声场，称为扩散声场法。若扩散声场的平均声压级为 $L_p$ ，则相应的声功率级为

$$L_w = L_p + 10 \lg V - 10 \lg T - 14 \quad (\text{dB})$$

式中： $V$ 为混响室容积（ $m^3$ ）； $T$ 为混响时间（s）。

如果测量充分扩散的声场，而混响室的房间常数为 $R$ ，测量充分扩散的声场声压级为 $L_p$ ，相应的声功率级为：

$$L_w = L_p + 10 \lg R - 6 \quad (\text{dB})$$

式中： $R$ 为混响室的房间常数

$$R = \frac{\alpha S}{1 - \alpha^2} (m^2)$$

其中， $\alpha$ 为吸声系数，一般 $\alpha=0\sim 1.0$ ； $S$ 为混响室的表面积。

事实上，实验室的边界对所有频率不可能做到完全吸收或完全反射，这种差异性规定了在实验室测定声功率级的精度要求（对声压级来说即为允许偏差的要求），这就必需有一个统一的测试规定即测试方法的标准。这里有两种，一种是以国际标准化组织指定的标准（即ISO标准）；另一种是美国AMCA或ASHRAE指定的标准属于行业性质的标准。两者的标准之间是存在一些区别的。

亿利达风机实验室所建的混响室与气动性能实验室结合在一起的风机测试实验室，属国内首创，符合AMCA300-96《风机声学测试——混响室法》的有关要求和规定。

## Sound Testing Method

Sound pressure level and sound intensity level can be measured from the sound level measuring meter or the sound intensity meter. Besides the three basic parameters of the sound, it is important to understand the sound frequency which will have to analyze the sound spectrum. The sound spectrum can be measured from the sound frequency analyzer. From the analysis of the sound spectrum, the sound level can be reduced and the radiation of the sound power level can also be reduced.

The sound power can be determined indirectly from the measuring of the sound pressure level. However the sound pressure level is not easy to measure, as it is influenced by the effects of the testing environment. In order to minimize the impact of the testing environment, two ideal state of the laboratory testing methods are created, free field method and reverberant field method.

When sound source is running in a given space, all the sound energy radiated from the sound source is absorbed by the boundary without reflection, and form a specific propagation of the sound waves in this space. This particular space is called the free field. The laboratory that simulates the free field is normally used full-anechoic room or semi-anechoic room. Conversely, if the sound energy is totally reflected by the boundary of this particular space with no absorption, and it forms another specific propagation of the sound waves in this space. This particular space is called the reverberant field. The laboratory that simulates the reverberant sound field is normally used the reverberant room.

Below is the introduction of the reverberant room.

A sound source is set in a closed room (reverberant room), after a time, a constant sound pressure level is produced in the room. In this stable state, if ignored the loss of the sound power due to the absorption of the air and the wall surround, the sound power is equal to the sound power releases from the sound source. This process is the direct sound field. After switching off the sound source, the sound does not disappear immediately, The sound energy in the room is gradually attenuated, this process is the diffuse sound field or the reverberant sound field. The reverberation time is defined as the time required to let the sound energy density attenuate to 60 dB (i.e. 10 to 6 times the original value). In the reverberant room, measuring the full diffusion of the sound field is known as the diffuse sound field method. The sound power level is corresponding to the average sound pressure level  $L_p$  in the diffuse sound field as follow:

Where  $V$  ----- the volume of the reverberant room ( $m^3$ )  
 $T$  ----- the reverberation time (s).

If the reverberant room constant is  $R$  and the sound pressure level measured in the full diffusion of the sound field is  $L_p$ , then the corresponding sound power level is :

Where  $R$  ----- the reverberant room constant  
And  $\alpha$  ----- the absorption coefficient, normally  $\alpha = 0 \sim 1.0$   
 $S$  ----- the surface area of the reverberant room.

In fact, all the sound frequencies can not be totally absorbed or reflected by the boundaries of the laboratory, this difference provides the accuracy requirement the sound power level measurement in the laboratory (it is the allowable deviation requirement of the sound pressure level). So, the test must have a unitary standard for the sound testing methods. There are two standards, one is the ISO standards, and the other is the AMCA or ASHRAE standards. There are some differences between the two standards. Yilida's comprehensive fan performance test laboratory has a reverberant room and an aerodynamic performance lab. This reverberant room is built in according to the requirements and the regulations of AMCA 300-96 (Reverberant Room Method for Sound Testing of Fans).



### 三、声音的计算

如前所述,当声音信号进入 A 计权网络时,低频的声音按比例衰减通过,而 1000Hz 以上的声音无衰减地通过。这种被 A 网络计权后的声压级,就称为 A 声级  $L_A$ 。它的单位为 dB。A 声级可以直接测量,也可以由 8 个倍频程声压级计算得到,其数学表达式为:

$$L_A = 10 \lg \sum_{i=1}^8 10^{0.1(L_{pi} + \Delta A_i)}$$

式中  $L_{pi}$ ——倍频程声压级,单位为 dB;  
 $\Delta A_i$ ——不同频率的计权衰减,见表 1,其中下表  $i=1, 2, \dots, 8$  分别代表 8 个倍频程中心频率 63, 125, 250, 500, 1000, 2000, 4000, 8000Hz。

中心频率 Center frequency/Hz	63	125	250	500	1000	2000	4000	8000
计权衰减 Weighted attenuated value /Hz	-26	-16	-9	-3	0	1	1	-1

通风机的 A 声级不仅与风机尺寸大小与转速有关,而且还取决于流量和压力的大小。为了比较不同型号及不同性能参数的通风机的噪声特性,可以引入比 A 声级  $L_{SA}$ , 通风机测试工况点比 A 声级的数学表达式:

$$L_{SA} = L_A - 10 \lg (q_v p_{tF}^2) + 19.8$$

式中  $L_{SA}$ ——通风机测试工况点的比 A 声级,单位为 dB(A);  
 $L_A$ ——通风机测试工况点的 A 声级,单位为 dB(A);  
 $q_v$ ——通风机测试工况点流量,单位为  $m^3/min$ ;  
 $p_{tF}$ ——通风机测试工况点全压,单位为 Pa。  
目前国内指定的通风机噪声标准都采用比 A 声级来评价通风机的噪声特性。

在实际工作中进行声音叠加时,可查曲线值来计算。见图 1。  
两个噪声相加,  $L_{p_{总}} = L_{p1} + L_{p2}$ , 规律总结如下:  
a) 总声压级不会比其中任一个大 3 分贝以上;  
b) 两个声压级相差 10 分贝以上时, 叠加增量可忽略不计。  
c) 两个声压级相差 10 分贝以下时, 查表确定增加量, 再与大的叠加。  
d) 对于多个声源, 只需两两逐次叠加即可, 和顺序没有关系。

图 1 两噪声源的叠加曲线  
Fig 1. Two noise sources superimposed curve

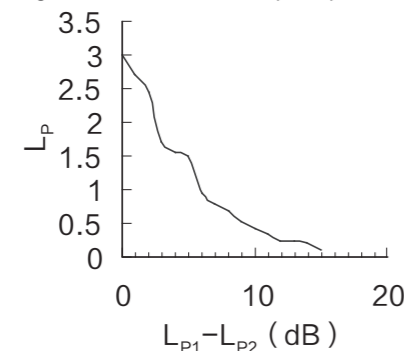

### Sound Calculation

As mentioned earlier, when the sound signal enters the A weighting network, the low-frequency sound will attenuate proportionally through the network. The sound pressure level that was adjusted by A weighting network is called A-weighted sound level  $L_A$ , its unit is dB(A). The A-weighted sound level can be measured directly, can also be calculated from the 8 octave bands of the sound pressure level. Its expression is:

Where  $L_{pi}$  ----- octave band sound pressure level, in dB  
 $\Delta A_i$  ----- weighted attenuated value, refer to table 1, in which  $i=1, 2, \dots, 8$  represent the 8 octave band centre frequency 63, 125, 250, 500, 1k, 2k, 4k, 8k Hz.

The A-weighted sound level of the fans is not only related with the fan size and the fan speed, but also depended on the air flow-rate and the pressure. In order to compare the sound characteristics of different models and different performance parameters, the specific A-weighted sound level  $L_{SA}$  is introduced. The specific A-weighted sound level is expressed as:

Where  $L_{SA}$  ----- the specific A-weighted sound level, in dB(A)  
 $L_A$  ----- the A-weighted sound level, in dB(A)  
 $q_v$  ----- the air flow-rate, in  $m^3/min$   
 $p_{tF}$  ----- the total pressure in Pa.

At present, the fan noise standards are using the specific A-weighted sound level to evaluate the noise characteristics of the fans.

In actual work, when the sounds are combining, the curve shown in Figure 1 can be used to calculate the value of the combined sounds.  
When two sounds are combined,  $L_{p_{total}} = L_{p1} + L_{p2}$ , the rules are as follow:  
a) The total sound pressure level is no more than any of the two sound pressure level by 3 dB.  
b) If the difference of the two sound pressure level is equal to, or more than 10 dB, the increment is negligible.  
c) When the difference of the two sound pressure level is less than 10 dB, then find the increment from the table, and add to the bigger sound pressure level.  
d) For more than two sound sources, just combine any two sound pressure level each time until the finished sound. pressure level is calculated, the sequence does not matter.

### 四、通风机噪声产生的原因

通风机的噪声主要包括空气动力所产生的噪声、机械振动所产生的噪声和两者共同作用产生的噪声 3 个方面。

- 1) 空气动力所产生的噪声
  - (a) 冲击噪声  
叶轮高速旋转时, 叶片作周期性运动, 空气质点受到周期性力的作用, 冲击压强波以声速传播所产生的噪声。
  - (b) 涡流噪声  
叶轮高速旋转时, 因气体边界分离而产生的涡流所引起的噪声
- 2) 机械振动性噪声  
回转体的不平衡及轴承的磨损、破坏等原因所产生的振动必然会产生噪声, 当叶片刚性不足, 气流作用使叶片振动, 也会产生噪声。
- 3) 两者相互作用而产生的噪声  
叶片旋转引起自身振动通过管道传递, 往往在管道弯曲部发生冲击和涡流, 造成振动加剧使噪声增大, 特别是当气流压强声波的频率与管道自身振动相同时, 将产生强烈的共振, 噪声会突然增大, 严重时将导致通风机破坏。

### The Causes of the Noise Generated

There are three causes of the fan noise generated: aerodynamic, mechanical vibration, between the aerodynamic and the vibration.

- 1) The noise generated by aerodynamic
  - (a) The impact noise  
When the impeller is rotating at a high speed and the blade is moving periodically, the air particle is affected by the periodic force, that pushes the pressure waves at the sound speed to generate noise.
  - (b) Turbulence Noise  
When the impeller is rotating at a high speed, there may have a swirl occurred at the inlet of the fan, then a noise is generated due to turbulence.
- 2) The noise from the mechanical vibration  
The unbalance impeller, the damaged bearing and others will cause vibration. The vibration will generate noise. If the blade is not rigid enough, it will vibrate when rotating that will also generate noise.
- 3) The noise generated from the interaction between the aerodynamic and the vibration  
Vibration caused by the rotating blades and transmitted through the duct, then occur impact and swirl in the bending of the duct that increase the vibration and increase the noise. Especially when the air pressure wave frequency is same as the vibration frequency of the duct that cause a strong resonance, then the noise suddenly increases. It can result in serious damage to the fan.

### 五、通风机噪声的控制

- 1) 设计良好的通风机  
在设计时, 为了防止或减少本身噪声源的产生, 应尽量减少气流的冲击, 避免尖锐突出和流道的急剧转弯。合理选择风机的转速大小, 注意控制叶轮和蜗舌的间隙, 此间隙越小, 噪声越大。
- 2) 消声器  
消声器一般可以通过吸收噪声源和进风口产生的噪声来隔音降噪。不同类型的风机用的消声器各有不同。

### The Control of the Noise of the Fans

- 1) Well-designed of Fans  
When design the fans, in order to prevent or reduce the generation of the sound source, should minimize the impact of the air flow, the side plate and the scroll must be smooth without uneven prominent, and avoid the sharp turn of the air flow. The fan speed must be selected correctly, and the gap between the cutoff and the wheel must be controlled, as the smaller the gap, the greater the noise.
- 2) Silencer  
Silencer can generally absorb the sound source and the noise generated from the inlet and the outlet of the fans. Different types of fans will use different kind of silencers.

## 一、选择风机的原则

风机选型时，首先要确定系统所需的流量和压力。由于风机样本中流量和压力等性能参数通常都是以标准大气状态下给出的，所以须将使用条件(如输送气体的温度、密度、工作点海拔高度或大气压力等)下系统所需的流量、压力等参数换算到标准大气状态，依此选择风机。  
通风机的标准大气状态，通常是指在海拔高度 0 m，温度 20℃，大气压力 101.325 kPa 时，输送相对湿度 50%，密度 1.2 kg/m<sup>3</sup> 的空气。

## 二、温度和海拔高度对空气的影响

但是在实际选型过程当中，有些风机的应用场合分布在不同的海拔和温度环境下，此时气体的密度随之影响很大。

1) 海拔高度对大气压力的影响，可用以下公式表示：

$$p_1 = p_0 \times (0.885)^Z \div 1000$$

注：p<sub>1</sub>——实际空气状态下压力；  
p<sub>0</sub>——标准状态下压力；  
Z——海拔高度。

2) 而温度根据工况点的实际情况定，温度及大气压力对大气密度的影响，可由下列公式表示：

$$\rho_1 = \rho_0 \left( \frac{p_1}{p_0} \times \frac{273 + t_0}{273 + t_1} \right)$$

式中：ρ<sub>0</sub>=1.2 kg/m<sup>3</sup>——标准大气状态下的密度；  
p<sub>0</sub>=101.325 kPa——标准大气状态的大气压力；  
t<sub>0</sub>=20℃——标准大气状态的温度；  
p<sub>1</sub>、ρ<sub>1</sub>、t<sub>1</sub>——分别为实际空气状态下的压力、密度和温度。

3) 设：

$$e = \frac{p_1}{p_0} \times \frac{273 + t_0}{273 + t_1}$$

可得：

e——大气密度的修正系数。

$$e = \frac{\rho_1}{\rho_0}$$

$$\therefore p_1 = p_0 \times (0.885)^Z \div 1000$$

可得：

$$e = \frac{(0.885)^Z}{1000} \times \frac{273 + t_0}{273 + t_1}$$

通过上式可得下表：

## The Principle of Fan Selection

First, we must determine the airflow and the pressure in the system. As the fan performance data in the catalog are usually given in the standard conditions, all the data of the operating point in the system must be converted to the standard atmospheric conditions before selection.

The standard atmospheric conditions are referred to altitude 0 m, temperature 20 °C, atmospheric pressure 101.325 kPa, air density 1.2 kg/m<sup>3</sup>.

## The Effects of Temperature and Altitude

Some fans are used in a high altitude and different temperature conditions, where the air density will vary accordingly. The effects of the temperature and the altitude must be considered, when doing selection.

1) The effect of the altitude to the atmospheric pressure can be expressed as the following formula:

Note: p<sub>1</sub>—— actual atmospheric pressure,  
p<sub>0</sub>—— standard atmospheric pressure,  
Z—— altitude.

2) The effects of the temperature and the atmospheric pressure to the air density can be expressed as the following formula:

where:  
ρ<sub>0</sub>=1.2kg/m<sup>3</sup>—— air density in the standard atmospheric condition,  
p<sub>0</sub>=101.325kPa—— standard atmospheric pressure,  
t<sub>0</sub>=20 °C —— temperature in the standard atmospheric condition,  
p<sub>1</sub>, ρ<sub>1</sub>, t<sub>1</sub>——actual atmospheric pressure, air density and temperature.

3) If

then:

e—— the correction factor of air density.

$$\therefore \frac{p_1}{p_0} = (0.885)^Z \div 1000$$

then:

From the above, the following table can be calculated:

大气密度的修正系数表  
Atmospheric density correction factor table

气温℃ Air Temperature	海拔 Altitude (单位:m)															
	0	400	800	1200	1600	2000	2400	2800	3200	3600	4000	4400	4800	5200	5600	6000
-40	1.26	1.20	1.14	1.09	1.04	0.99	0.94	0.89	0.85	0.81	0.76	0.73	0.69	0.65	0.62	0.59
-20	1.16	1.11	1.05	1.00	0.96	0.91	0.87	0.82	0.78	0.74	0.70	0.67	0.64	0.60	0.57	0.54
0	1.07	1.03	0.98	0.93	0.89	0.84	0.80	0.76	0.73	0.69	0.65	0.62	0.59	0.56	0.53	0.50
20	1.00	0.96	0.91	0.87	0.83	0.78	0.75	0.71	0.68	0.64	0.61	0.58	0.55	0.52	0.49	0.47
40	0.94	0.89	0.85	0.81	0.77	0.73	0.70	0.67	0.63	0.60	0.57	0.54	0.51	0.49	0.46	0.44
60	0.88	0.84	0.80	0.76	0.73	0.69	0.66	0.63	0.59	0.56	0.54	0.51	0.48	0.46	0.43	0.41
80	0.83	0.79	0.76	0.72	0.69	0.65	0.62	0.59	0.56	0.53	0.51	0.48	0.46	0.43	0.41	0.39
100	0.79	0.75	0.71	0.68	0.65	0.62	0.59	0.56	0.53	0.50	0.48	0.45	0.43	0.41	0.39	0.37
140	0.71	0.68	0.65	0.62	0.59	0.56	0.53	0.50	0.48	0.46	0.43	0.41	0.39	0.37	0.35	0.33
180	0.65	0.62	0.59	0.56	0.53	0.51	0.48	0.46	0.44	0.42	0.39	0.37	0.35	0.34	0.32	0.30
220	0.59	0.57	0.54	0.52	0.49	0.47	0.44	0.42	0.40	0.38	0.36	0.34	0.33	0.31	0.29	0.28
260	0.55	0.53	0.50	0.48	0.45	0.43	0.41	0.39	0.37	0.35	0.33	0.32	0.30	0.29	0.27	0.26
300	0.51	0.49	0.47	0.44	0.42	0.40	0.38	0.36	0.35	0.33	0.31	0.30	0.28	0.27	0.25	0.24
350	0.47	0.45	0.43	0.41	0.39	0.37	0.35	0.33	0.32	0.30	0.29	0.27	0.26	0.24	0.23	0.22
400	0.44	0.42	0.40	0.38	0.36	0.34	0.33	0.31	0.29	0.28	0.27	0.25	0.24	0.23	0.21	0.20
450	0.41	0.39	0.37	0.35	0.33	0.32	0.30	0.29	0.27	0.26	0.25	0.23	0.22	0.21	0.20	0.19
500	0.38	0.36	0.35	0.33	0.31	0.30	0.28	0.27	0.26	0.24	0.23	0.22	0.21	0.20	0.19	0.18

注：当实际温度或海拔高度不在表中时，可进行数据的穿插计算  
Note: When the actual temperature or altitude is not on the table, the data can be interspersed calculation

表 1

Fig 1

例 1：某化工行业项目在海拔 0 米，平均气温 10℃的环境需要一台双进风后向离心风机来送风，客户要求的是质量流量为 12000 kg/h，静压为 500 Pa。

E.g. 1: A chemical factory which is located at an altitude 0 m and average temperature 10 °C place needs a DIDW centrifugal fan to supply air. The required mass flow rate is 12000 kg/h and the static pressure is 500 Pa.

解：当具体风机选型时，需考虑两方面因素，一方面是所给流量参数是质量流量(单位是 kg/h)还是体积流量(单位是 m<sup>3</sup>/h)；如果给的是体积流量那就按实际值计算。如果给的是质量流量，那要转化成体积流量。一般情况下默认是体积流量。  
第二方面考虑的内容压力 P。当一定的风机尺寸和一定转速，密度发生变化时，所有压力变化与密度成正比，功率和密度也是成正比的。

Before selection, the following must be considered:  
First, if the flow rate given is mass flow rate, then convert the mass flow rate to the volume flow rate.  
Second, when there is a difference in the air density, the pressure p must be converted to the pressure in the standard atmospheric condition.

通过查表可得海拔 0 米，气温 10℃时密度系数 e 为 1.07。  
转化到标准大气状态下：

From the table, at altitude 0 m and temperature 10 °C, the corrective factor of the air density e is 1.07.  
Convert to standard atmospheric condition:

$$q_{V1} = \frac{q_{m1}}{\rho_1} \quad \rho_1 = \rho_0 \times e \quad \therefore q_{V1} = \frac{q_{m1}}{\rho_0 \times e} = \frac{12000 \text{ kg/h}}{1.2 \text{ kg/m}^3 \times 1.07} = 9346 \text{ m}^3/\text{h}$$

因为在一定的风机尺寸和一定的转速，密度变化时：流量不受影响。

Because the volume flow rate is unchanged when the air density is changing, but the fan diameter and rpm are not changing.

$$\therefore q_{V0} = q_{V1} = 9346 \text{ m}^3/\text{h}$$

$$\frac{p_1}{p_0} = \frac{\rho_1}{\rho_0} = e \quad \therefore p_0 = p_1 \div e = 500 \text{ Pa} \div 1.07 = 467 \text{ Pa}$$

选型可得风机型号为 SYD450K，风机转速 735 r/min，风机轴功率为 1.824 kW，电机功率为 2.2 kW。

From the above data, the fan selected is SYD 450 K, fan speed is 735 r/min, shaft power is 1.824 kW and the motor power is 2.2 kW.



此前一直正常运行,随着进入夏季,该厂在实际生产中发现风机性能达不到要求,于是找到生产厂家寻求解决办法。

解:通过询问该厂的环境情况得知,目前该厂最高温度在 40℃;通过查表可得海拔 0 米,气温 40℃时密度系数 e 为 0.94。转化到标准大气状态下:

$$q_{V1} = \frac{q_{m1}}{\rho_1} \quad \therefore q_{V1} = \frac{q_{m1}}{\rho_0 \times e} = \frac{12000 \text{ kg/h}}{1.2 \text{ kg/m}^3 \times 0.94} = 10638 \text{ m}^3/\text{h}$$

同理可得:

$$q_{V0} = q_{V1} = 10638 \text{ m}^3/\text{h}$$

$$\frac{p_1}{p_0} = \frac{\rho_1}{\rho_0} = e \quad \therefore p_0 = p_1 \div e = 500 \text{ Pa} \div 0.94 = 532 \text{ Pa}$$

选型可得风机型号为 SYD450K, 风机转速 775 r/min, 风机轴功率为 2.323 kW, 电机功率为 3 kW。针对这种温度变化,使用者对风量要求比较严格的情况:建议使用 3 kW 的变频电机,变频调节风机转速或者配 3 kW 的普通电机再配上风量调节阀来控制。

例 1:某工程项目在海拔 800 米,气温 60℃的环境需要一台单进风后向离心风机来送风,风量为 20000m³/h,静压为 900Pa。请选型。

解:通过查表可得海拔 800 米,气温 60℃时密度系数 e 为 0.80。转化到标准大气状态下:

$$\frac{p_1}{p_0} = \frac{\rho_1}{\rho_0} = e \quad \therefore p_0 = p_1 \div e = 900 \text{ Pa} \div 0.80 = 1125 \text{ Pa}$$

压力按 1125 Pa 选型可得风机型号为 SYQS900E, 风机转速 933 r/min, 风机轴功率为 8.124 kW, 电机功率为 11 kW。可后来根据实际需要又将设备移到海拔 3000 m 的环境下使用,发现此时静压不够,求解决问题的方法。

解:通过查表可得海拔 3200 米,气温 60℃时密度系数 e 为 0.59。转化到标准大气状态下:

$$\frac{p_1}{p_0} = \frac{\rho_1}{\rho_0} = e \quad \therefore p_0 = p_1 \div e = 900 \text{ Pa} \div 0.59 = 1525 \text{ Pa}$$

压力按 1525 Pa 选型可得风机型号为 SYQS900E, 风机速 1061 r/min, 风机轴功率为 11.35 kW, 电机功率为 15 kW。此时需要更换电机和皮带轮才能满足工况需求。

In summer, the client find that the air flow does not meet the requirement, so he calls for help.

Knowing that the temperature now is 40℃, from the table, at altitude 0 m and temperature 40℃, the corrective factor of the air density e is 0.94. Convert to standard atmospheric condition:

Similarly:

From the data above, the fan selected is SYD 450 K, fan speed is 775 r/min, brake horsepower is 2.323 kW and the motor power is 3 kW. For this project, the air mass flow rate must be constant, so it is recommended to use 3 kW motor. By using the VFD to change the motor speed or using damper to control the air volume, to ensure that the air mass flow rate is constant.

E.g. 2: A project which is located at altitude 800 m and average temperature 60℃ place requires a single inlet backward inclined centrifugal fan to supply air. The air volume is 20000 m³/h and the static pressure is 900 Pa.

From the table, at altitude 800 m and temperature 60℃, the corrective factor of the air density e is 0.80. Convert to standard atmospheric condition:

From the above data, the fan selected is SYQS 900 E, fan speed is 933 r/min, brake horsepower is 8.124 kW and the motor power is 11 kW. After some times, the fan is moved to a location at altitude 3200 m and temperature 60℃, then find that the static pressure is not enough for the operating. Find the solution.

From the table, at altitude 3200 m and temperature 60℃, the corrective factor of the air density e is 0.59. Convert to standard atmospheric condition:

From the above data, the fan selected is SYQS 900 E, fan speed is 1061 r/min, brake horsepower is 11.35 kW and the motor power is 15 kW. So, to solve the problem, the motor and the drive package must be changed to satisfy the requirement.

## SYT 系列离心式空调风机

## Centrifugal Ventilators

浙江亿利达风机股份有限公司特此证明,此处所示 SYT 系列离心风机获得了加盖 AMCA 印章的授权。所示额定值系根据 AMCA 出版物 211 和 AMCA 出版物 311 所进行测试和程序确定,并符合 AMCA 认证额定值计划的要求。

这里描述的所有离心风机都已经取得了 AMCA 印章,他们的认证数据见第 035 页到 046 页。

Zhejiang Yilida Ventilator Co.,Ltd.certifies that the SYT Series fans shown herein are licensed to bear the AMCA Seal. The ratings shown are based on tests and procedures performed in accordance with AMCA Publication 211 and AMCA Publication 311 and comply with the requirements of the AMCA Certified Ratings Program.

All the Centrifugal Fans described herein are licensed to bear the AMCA Seal, and their certified ratings are shown on pages 035 through 046.



## 概述

SYT 系列离心式空调风机采用国际同类产品先进技术自行开发生产, 通过了 AMCA 国际认证并取得 AMCA 印章。该样本中列出的 12 种规格风机, 流量范围从 1000m<sup>3</sup>/h-40000 m<sup>3</sup>/h。SYT 系列风机采用前向多翼叶轮, 具有通用性强、效率高、噪音低、耗能少等特点。是各类中央空调机组及其他暖通空调、净化、通风等设备理想的配套产品。

## Summary

The SYT Series of centrifugal air conditioning fans was developed with advanced technologies. They are licensed to bear the AMCA Seal for air performance, sound, and FEG. The SYT Series includes 12 models as described in this catalogue. The volume flow of the SYT Series ranges from 1,000 m<sup>3</sup>/h to 40,000 m<sup>3</sup>/h. Some of the features and characteristics of these fans are: forward impeller blades, a wide range of applications, high efficiency, low noise, and low power consumption. These fans are ideal for use in central air-conditioning systems, in purifiers. They are also suitable for use in a variety of other ventilation applications.

## 命名方式

## Nomenclature

SYT 7 - 7 L



## 产品型式

## Product Features

### 1. 旋向

SYT 系列风机可分为左旋(LG)和右旋(RD)两种旋转方式, 从风机皮带轮一段正视, 叶轮顺时针旋转的称为右旋风机, 逆时针旋转的称为左旋风机。

### 1. Rotation

SYT series fans have two direction of rotations, left-hand rotation (LG) and right-hand rotation (RD); Viewing from drive side, if the impeller rotates clockwise, it is left hand (LG) rotation. If the impeller rotates counter clockwise, it is right-hand (RD).

### 2. 出风口方向

SYT 系列出风口可按图 1 所示制成 0°、90°、180°、270° 四种出风方向。

### 2. Discharge Direction

As shown in Fig1, SYT Series fans can be constructed in four discharge directions: 0°, 90°, 180°, and 270°.

图1(Fig 1)

	0°	90°	180°	270°
左旋 LG Left Hand				
右旋 RD Right Hand				

### 3. 结构形式

SYT 系列风机可按图 2 所示制成 L 型、LK、R 型、RK 型、L2 型、R2 型。

### 3. type of Construction

As shown in Fig 2, SYT series fans can be divided into category L, R, K, category R2, K2.

图2(Fig 2)

风机类型 Fan Type	机号 Fan Size	风机示意图 Fan Diagram	轴承实物图 Bearing Type
L、LK 型 TYPE L, LK	7-18in		
R、RK 型 TYPE R, RK	7-18in		
K 型 TYPE K	20-30in		
L2 型 TYPE L2	7-18in		
R2 型 TYPE R2	7-18in		



## 产品结构

SYT 系列风机主要由机壳、叶轮、框架、轴承、及轴构成。出口法兰(为可选件)。

### 1. 机壳

机壳采用热镀锌钢板制造,侧板具有符合空气动力学的外形,进风口整体拉伸成型,蜗板采用点焊或“Pittsburg seam locking”的连接方式与侧板连成一体。

### 2. 叶轮

前向多翼叶轮采用优质热镀锌钢板制成,叶片设计成符合空气动力学的特定形状,使得效率最高,噪声最低。叶片用铆爪固定在中盘及端圈上,在最大功率连续运转时,叶轮将具备足够的刚度。所有叶轮进行静平衡和动平衡测试,内控精度达到 G2.5 级(ANSI/AMCA 204-05)。

### 3. 框架

L、R 型风机框架采用热镀锌钢板剪切、折弯制成,TOX 连接保证了所需的尺寸精度和应有的刚度;K 型风机框架由角钢和扁钢冷弯焊接制成,轴承安装位进行对称铣平面加工,表面喷塑处理,以保证足够的刚度和强度,同时保证安装轴和轴承的同轴度。

### 4. 轴承

SYT 系列风机均采用优质滚珠轴承,并根据噪声最低来选择,该轴承设有加润滑油的孔,已预先加润滑油并自动对中;L/R 型风机的轴承安装在轴承支架上,并设有防振垫圈;K 型风机则采用带座向心球轴承。轴承寿命为  $L_{10} \geq 100000$  小时。

### 5. 轴

风机轴采用 40Cr 低合金钢,经车、调质热处理、磨削制成,强度高,挠度小,严格控制轴径尺寸公差及形位公差,每根轴均经过涂覆防锈处理。轴尺寸设计应满足第一临界转速至少为风机最大运行转速的 1.4 倍。

### 6. 出风口法兰

法兰采用热镀锌钢板制成,法兰与蜗壳的连接采用 TOX 免焊工艺,外观精美,并具有足够的刚度与强度。

## Construction of Product

SYT series fans are mainly constructed of housing, impeller, frame, bearing and shaft. Outlet flange (is optional).

### 1. Housing

The housing is made of hot galvanized steel sheet. The side plates include inlets cones that are designed with the best aerodynamics for inlet condition. The scroll is fixed to the side plates by spot welding or "Pittsburg seam locking."

### 2. Impeller

Forward curved impeller is constructed of high-grade hot galvanized steel sheet with the advanced aerodynamics profile to achieve the highest efficiency and the lowest noise level. The impeller is fixed on the center plate and on the end ring with riveting grip pres. The impeller is constructed with maximum strength that endures the continuous operation with maximum power. All impellers are balanced to ANSI/AMCA Standard 204-05. Yilida's internal standard is G2.5 or higher for wheel balancing.

### 3. Frame

The frames for type R and tyoe L constructions are made of galvanized steel angle iron bars. The cutting and bending of the frame parts, as well as the TOX connections, are formed with the use of toolings to ensure the high accuracy and the rigidity of the frames; The farmes for K constructions are welded by angle steel and flat steel, and finished with polyester coating in order to ensure sufficient rigidity and strength. The bearing supports are machined to ensure proper installation and alignments of the bearings.

### 4. Bearings

Ball bearings are used in all of the SYT Series fans. They are high quality bearings and they are selected to minimize the noise levels. The bearings are pre-lubricated, sealed, and self-centering. For type R and L fans, the bearings are remounted using vibration resistant washers. For type K fans bearing are supplied with lubrication fittings..Bearing service life for  $L_{10} \geq 100000$  hours.

### 5. Shaft

The shafts are made of 40 Cr carbon steel bars. The shafts are rough machined and then stress relieved with heat treatment before final machining. The shaft diameters are machined to very accurate tolerance levels, and they are fully checked to ensure precision fit. Each shaft is made turned, ground and polished. They are coated after assembly to provide corrosion resistance. Shaft size should be designed to meet the first critical speed of at least fan maximum running speed 1.4 times.

### 6. Outlet Flange

The outlet flange is made of galvanized steel. The connections of the flange components to the scroll are made using a TOX non-welding process. This maintains a good flange appearance while also providing sufficient strength and rigidity.

## 风机性能

### 1. 风机选型示意图例

型号 Type	SYT18-13R
风量 Volume	$q_v=8000\text{m}^3/\text{h}$
全压 Total Pressure	$P_{IF}=500\text{Pa}$
动压 Dynamic Pressure	$P_{DF}=70\text{Pa}$
出口速度 Outlet Velocity	$C=10.81\text{m/s}$
风机转速 Fan Speed	$n=761\text{r/min}$
轴功率 Shaft Power	$P_{in}=1.63\text{KW}$
A声功率级 A Sound Power Level	$L_{WA}=79\text{dB(A)}$
全压效率 Total Efficiency	$\eta_{IF}=68.3\%$

## Performance Chart

### 1. Fan Performance Curve

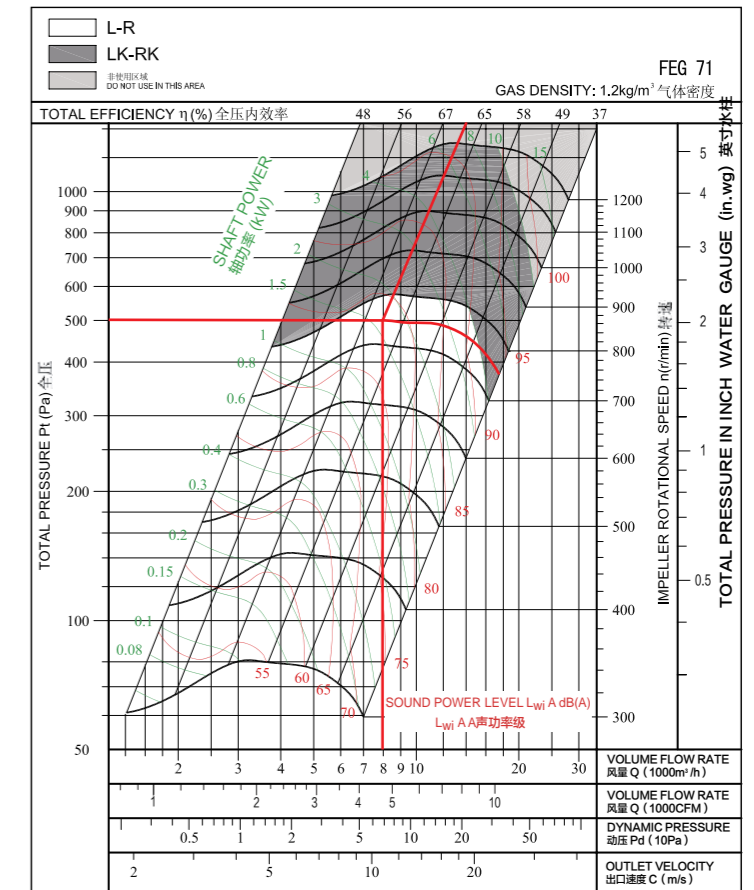

## 2、电机的选配

性能曲线图上的功率 Psh 是指风机轴功率。  
配套电机的功率： $P_{sh,p} = P_{sh} \times K \div \eta_{me}$   
风机传动效率的取值方法可参照表 1，  
电机容量安全系数的取值方法可参照表 2。

表 1 (Table 1)

风机传动方式 Drive Type	$\eta_{me}$
电机直联传动 Motor direct drive	1
联轴器直联传动 Coupling direct drive	0.98
三角皮带传动 V-belt drive	0.95

## 3. 双联风机的性能计算

L2 型、R2 型、K2 型双联风机性能与 L 型、R 型、K 型风机曲线上所示性能比较，在压力相同的情况下，双联风机性能如下：

风量	x2	转速	x1.05
轴功率	x2.15	噪声	+3 dB

双联风机的性能未获得 AMCA International 授权。

## 2. Motor selection

The power (Psh) on the performance chart refers to the shaft power of the fan.  
The rated power of the drive motor equals the total required shaft input multiplied by the safety factor :  $P_{sh,p} = P_{sh} \times K + \eta_{me}$   
The value of mechanical drive efficiency can be obtained from Table 1.  
The required safety factors is provided in Table 2.

表 2 (Table 2)

电机功率 Power of electric motor (Kw)	K 值 Value k
$\leq 0.75Kw$	1.3
$\leq 2.2Kw$	1.2
$\leq 7.5Kw$	1.15
$\geq 11Kw$	1.1

## 3. The twin fans' performance calculation is the double fan performance calculation formula:

Comparing the performance of the twin fan of Category L2 Category R2 and Category K2 with the performance of Category L Category R and K in the chart in the same condition of pressure, the twin fans' performance is as the following.

Volume	x2	Speed	x1.05
Shaft Power	x2.15	Noise	+3 dB

Performance of twin fans are not licensed by AMCA International.

## 安装与维护

### A) 皮带传动安装

1. 拆除风机轴端的保护并检查有无缺口和毛刺；
2. 检查风机和电机轴之间的平行度；
3. 中心距控制在  $0.7(d1+d2) < a < 2(d1+d2)$ ，前向风机皮带速度应控制在 10~15m/s；后向风机皮带速度应控制在 25~35m/s；
4. 将皮带轮套在轴上滑进去，不要敲击，以免损伤轴承；
5. 用一根直尺把风机和电机上的带轮对齐并紧固；
6. 把皮带套进皮带轮，不要撬、挤压，以免损伤皮带；

## Installation and Maintenance

### A) V-belt drive Installation

1. Remove the protective coating from the ends of the fan shaft and ensure that the shaft ends are free of nick and burrs.
2. Check fan and motor shafts for alignment.
3. The center distance must be controlled as  $0.7(d1+d2) < a < 2(d1+d2)$ . The belt speed of forward curve fan should be more than 10m/s, but less than 15m/s, ( $10 < v < 15m/s$ ). The belt speed of backward curve fan should be more 25m/s, but less than 35m/s ( $25 < v < 35m/s$ ).
4. Slide sheaves on to the shafts, Do not hammer the sheaves on to the shafts with force as this may result in bearing damage.
5. Align fan and motor sheaves with a straight-edge, and tighten the sheaves.
6. Place belts over the sheaves with care. Do not bend or squeeze the belts, or it might get damaged.

7. 调整张进度直至皮带看起来松紧适度，风机运行几分钟后，再调整皮带至合适的张紧度；
8. 关掉风机，移动电机座以调整张紧度，当风机工作时，皮带紧的一边是两个皮带轮连成的一条直线，松的一边有轻微弧形。

图 3 (Fig3)

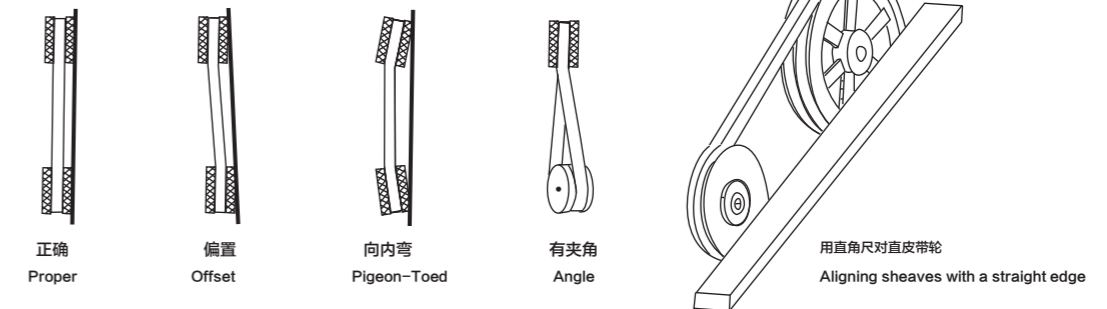

### B) 皮带松紧度

合适的皮带松紧度对使用寿命来说很重要，太紧会给皮带和轴承带来额外的负载，降低它们的使用寿命，太松会出现皮带打滑现象而产生热能并降低使用寿命。  
皮带松紧度量具用来判断皮带是否松紧合适。量具本身带有一个尺表，根据皮带轮中心距和皮带横截面确定皮带张紧力的大小，如图 4 和表 3。  
如没有皮带张紧度量具，应调节皮带松紧至风机启动时皮带不发生尖叫声为止，如发生短促的叫声是允许的。  
拉紧皮带后、开动风机之前，重新检查皮带轮的对齐情况，如右必要则重新调整对齐。新皮带在开始使用时可能有点拉伸，则应在运行几天后重新检查皮带张紧度。

图 4 (Fig4)

与中心距有关的皮带张紧度指示  
Belt tension indicator applied to mid centre distance.

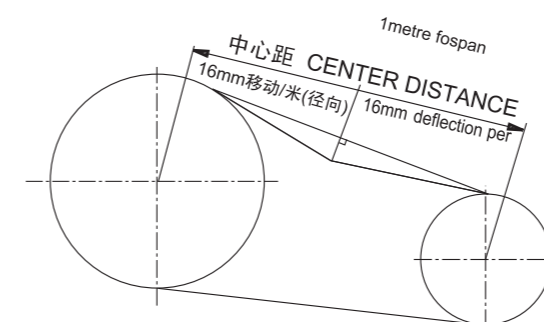

7. Adjust the belt tension until the belts appear snug. Run the unit for a few minutes and allow the belts to set properly.
8. Switch off the fan, adjust the belt tension by moving the motor base. When in operation, the tight side of the belts should be in a straight line from sheave to sheave and there should be a slight bow on the slack side.

### B) Belt tension

A proper level of belt tension is required in order to obtain a satisfactory belt life. If the belt tension level is too high, excessive loads will be imposed on the belts and the bearing, and this will reduce the lives of both of these components. If the belt tension level is too low, the belt will slip. Belt slippage generates a large amount of heat, and this heat will drastically reduce the life of a belt.  
Belt-tensioning gauges can be used to determine whether the belts are tensioned properly. A chart is normally supplied with the gauge which indicates the ranges of forces required to deflect the belts by a given amount to obtain the proper belt tension level. The required forces are based upon the center distance of the sheaves and the belt cross-section. The belts are properly tensioned when the forces required to deflect the belt are within the specified range, see Fig 4 and Table 3.  
If a belt-tensioning gauge is not available, then the belt should be tightened just enough so that the belt does not squeal when the fan is started. A very short period of noise during the starting of a fans is allowable, but a squeal lasting several seconds or longer is not acceptable. After tensioning the belts and before starting the fan, check to make sure that the sheaves is properly aligned.  
Realign the sheaves if necessary. Note that new belts may stretch a little during initial use, so the belt tension level should be checked after a few days of operation.

表 3 (Table 3)

皮带截面 Belt Section	使皮带向下移动16mm径向距离1米所需的力 Force required to deflect belt 16mm per metre of span		
	张紧力 (小皮带轮直径) Small Pulley Diameter (mm)	牛顿 Newtonian (N)	千克力 Kilogram force (Kgf)
SPZ	56-95	13-20	1.3-2.0
	100-140	20-25	2.0-2.5
SPA	80-140	25-35	2.5-3.6
	140-200	35-45	3.6-4.6
SPB	112-224	45-65	4.6-6.6
	236-315	65-85	6.6-8.7
SPC	224-335	85-115	8.7-11.7
	375-560	115-150	11.7-15.3
A	40-140	10-15	1.1-1.5
B	125-200	20-30	2.0-3.1

### C) 轴承润滑

风机使用带座轴承, 可通过加油嘴注入润滑油。润滑油有效期取决于油脂类型、轴承的转速和工作温度。判断是否加油的最好办法是当加新油时观察清除下来的旧油脂, 可延长换油脂的间隔, 如果清除下来的油脂比新的黑得多表明油脂已氧化, 应缩短换油脂的间隔。

### C) Bearing Lubrication

The fan bearings are filled with lubricant when they ship from the factory, so the bearings do not require any additional grease to be supplied before starting the fan. The fans that are equipped with pillow block bearing are provided with lubrication fittings, and these fittings allow for additional lubrication to be supplied to the bearings at regular intervals. The allowable period of time between lubrication of these bearings depends upon the operating speeds and temperatures of the bearing as well as on the type of lubrication. It is recommended to inspect the condition of the grease that is discharged from the bearings when new grease is added. If the discharged grease looks similar to the new grease, then a longer period of time between lubrications is possible. If the discharged grease is much darker than the new grease, this indicates that the grease is being oxidized and more frequent lubrications of the bearings are required.

### 说明

- 1). 订货时须注明风机型号、转速、风量、风压、出风口方向和旋转方向。若需配套皮带、皮带轮、电机、安装底座等配件及其它特殊要求可在订货时提出。
- 2). 在安装前应对风机各部件进行检查, 对叶轮、主轴和轴承等主要机件应重点细致检查, 如有损伤应修复后再安装使用。
- 3). 检查机壳和其它壳体内部, 不应有掉入、遗留的工具和杂物。
- 4). 风机正式运转前, 需检查电机的转向是否符合风机转向的要求。
- 5). 风管与出风口之间应采用软连接, 接头不得拉紧。
- 6). 风机安装后用手或杠杆拨动叶轮, 检查是否过紧或碰撞现象, 确认无这些现象时方可进行试转。
- 7). 风机配用电动机功率是指在特定工况下, 风机内功率加上机械损失与电机容量安全系数而言, 并非出风口全敞开时所需的功率。为防止电机超功率运行而烧毁, 严禁风机出风口或进风口不接管路或未加外界任何阻力进行空运转。
- 8). 风机在无较大腐蚀性气体、不含酸(碱)性和尘颗粒物小于 150mg/m<sup>3</sup> 的气体、温度小于 85℃ 大于 -20℃ 的气体环境下使用, 风机在运输装卸过程中应小心轻放, 防止碰撞挤压。

### Instructions

- 1) When placing the order, it is necessary to state the type of fan, speed, air volume, air pressure, discharge direction, rotation direction, type of electric motor and its specifications.
- 2) Prior to installation, the fan should be carefully inspected. Special care should be taken in checking the shaft, impeller and bearings. If there is an indication of any damage, the damaged parts should be repaired or replaced before the fan is installed or commissioned.
- 3) The inside of the scroll and casing need to be checked to make sure that there are no foreign objects inside the housing, such as tools or loose parts.
- 4) The rotational directions of the motor and impeller should be checked to ensure that they are in compliance with the specification and purchase orders.
- 5) A flexible connector should be used between the fan out let flange and its mating ductwork. The flex connector should not be over-stretched.
- 6) Following the installation, the impeller should be turned by hand or with the use of a wrench to make sure that it turns freely without colliding with other parts of the fan. Once all this is done, the fan can be commissioned normally.
- 7) The rated motor power as calculated herein might not be sufficient to drive the fan with an unrestricted discharge flow. Operating the fan with an unrestricted discharge outlet will result in flow rate that exceeds the specified fan capabilities. Such operation will quickly burn the motor and damage the fan. Great care must be taken in operating the fan to make sure that the maximum rated flows, as provided on the performance charts in this catalog, are not exceeded.
- 8) The fan is limited for use in areas where air substances are non-corrosive, non-toxics and non-erosive and where dust particles are less than 150mg/m<sup>3</sup> with a temperature between -20°C and 85°C. Special care should be taken during transportation, load and unload.

### 技术参数

### Technical Data

Wheel diameter	叶轮直径	D = 7 inch	Fan weight	风机质量	m = 8.5 kg
Moment of inertia	转动惯量	J = 0.009 kg·m <sup>2</sup>	Speed limit	极限转速	n <sub>max</sub> = 2200 r/min

### 性能曲线

### Performance Curves

经认证的性能是B类安装: 自由入口, 管道出口。功率额定值(kW)不包括传输损失。各项性能额定值不包括附属物(附件)的影响。所示A加权声音性能额定值已按AMCA International标准301计算。所示值为安装类型B: 自由入口, 管道出口的声功率级(入口L<sub>wA</sub>)。

Performance certified is for installation type B: free inlet, ducted outlet. Power rating (kW) does not include transmission losses. Performance ratings do not include the effects of appurtenances (accessories). The A-weighted sound ratings shown have been calculated per AMCA International Standard 301. Values shown are for inlet L<sub>wA</sub> sound power levels for installation type B: free inlet, ducted outlet.

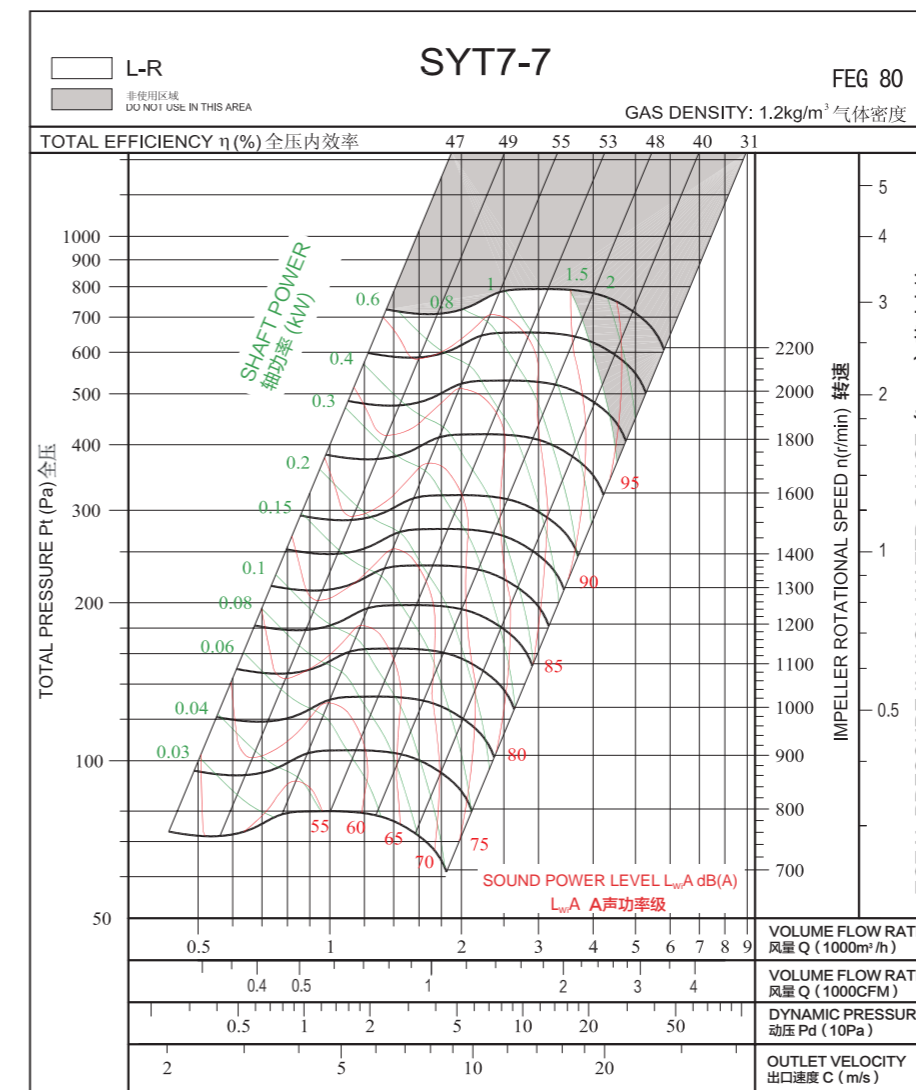

Measured in installation B according to AMCA Standard 210:

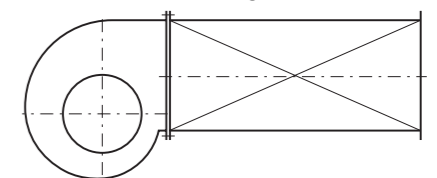



## 技术参数

## Technical Data

Wheel diameter 叶轮直径	D = 8 inch	Fan weight 风机质量	m = 9.5 kg
Moment of inertia 转动惯量	J = 0.015 kg·m <sup>2</sup>	Speed limit 极限转速	n <sub>max</sub> = 2200 r/min

## 技术参数

## Technical Data

Wheel diameter 叶轮直径	D = 9 inch	Fan weight 风机质量	m = 10.2 kg
Moment of inertia 转动惯量	J = 0.029 kg·m <sup>2</sup>	Speed limit 极限转速	n <sub>max</sub> = 2200 r/min

## 性能曲线

## Performance Curves

经认证的性能是B类安装：自由入口，管道出口。功率额定值(kW)不包括传输损失。各项性能额定值不包括附属物(附件)的影响。所示A加权声音性能额定值已按AMCA International标准301计算。所示值为安装类型B：自由入口，管道出口的声功率级（入口L<sub>WA</sub>）。

Performance certified is for installation type B: free inlet, ducted outlet. Power rating (kW) does not include transmission losses. Performance ratings do not include the effects of appurtenances (accessories). The A-weighted sound ratings shown have been calculated per AMCA International Standard 301. Values shown are for inlet L<sub>WA</sub> sound power levels for installation type B: free inlet, ducted outlet.

## 性能曲线

## Performance Curves

经认证的性能是B类安装：自由入口，管道出口。功率额定值(kW)不包括传输损失。各项性能额定值不包括附属物(附件)的影响。所示A加权声音性能额定值已按AMCA International标准301计算。所示值为安装类型B：自由入口，管道出口的声功率级（入口L<sub>WA</sub>）。

Performance certified is for installation type B: free inlet, ducted outlet. Power rating (kW) does not include transmission losses. Performance ratings do not include the effects of appurtenances (accessories). The A-weighted sound ratings shown have been calculated per AMCA International Standard 301. Values shown are for inlet L<sub>WA</sub> sound power levels for installation type B: free inlet, ducted outlet.

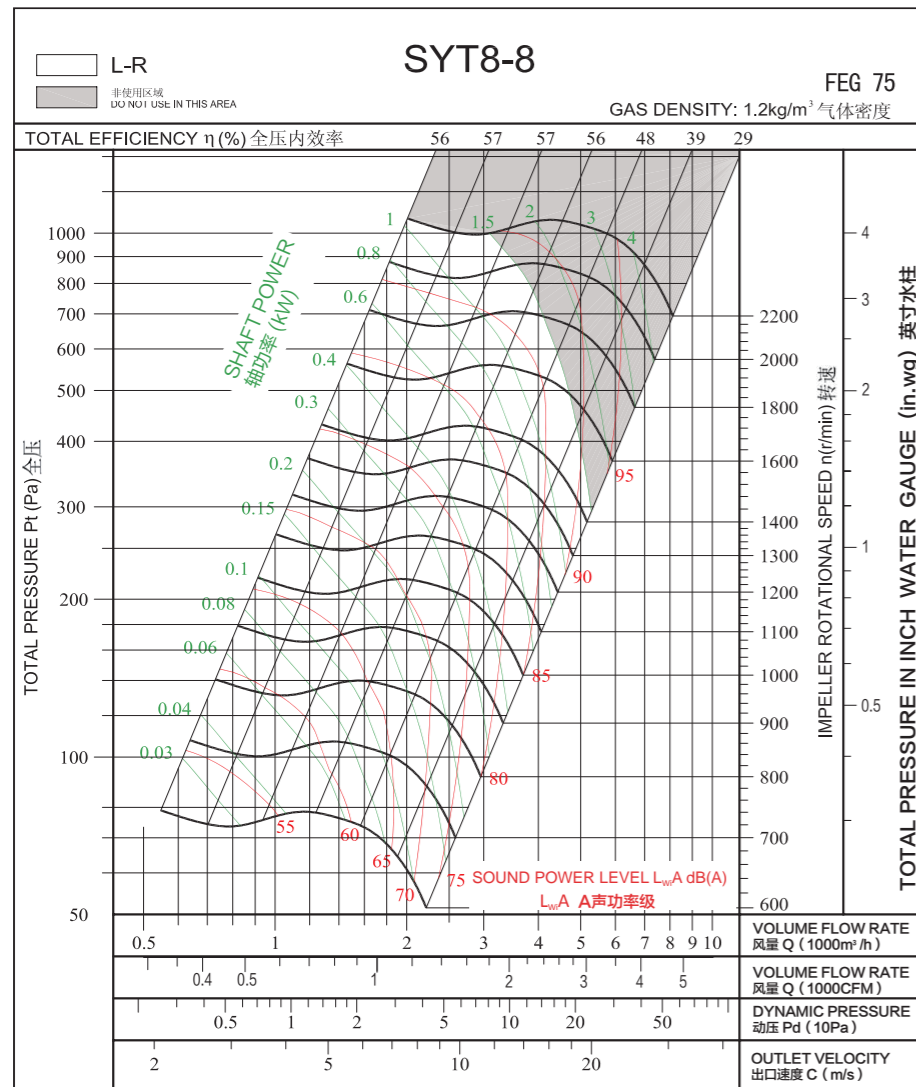

Measured in installation B according to AMCA Standard 210:

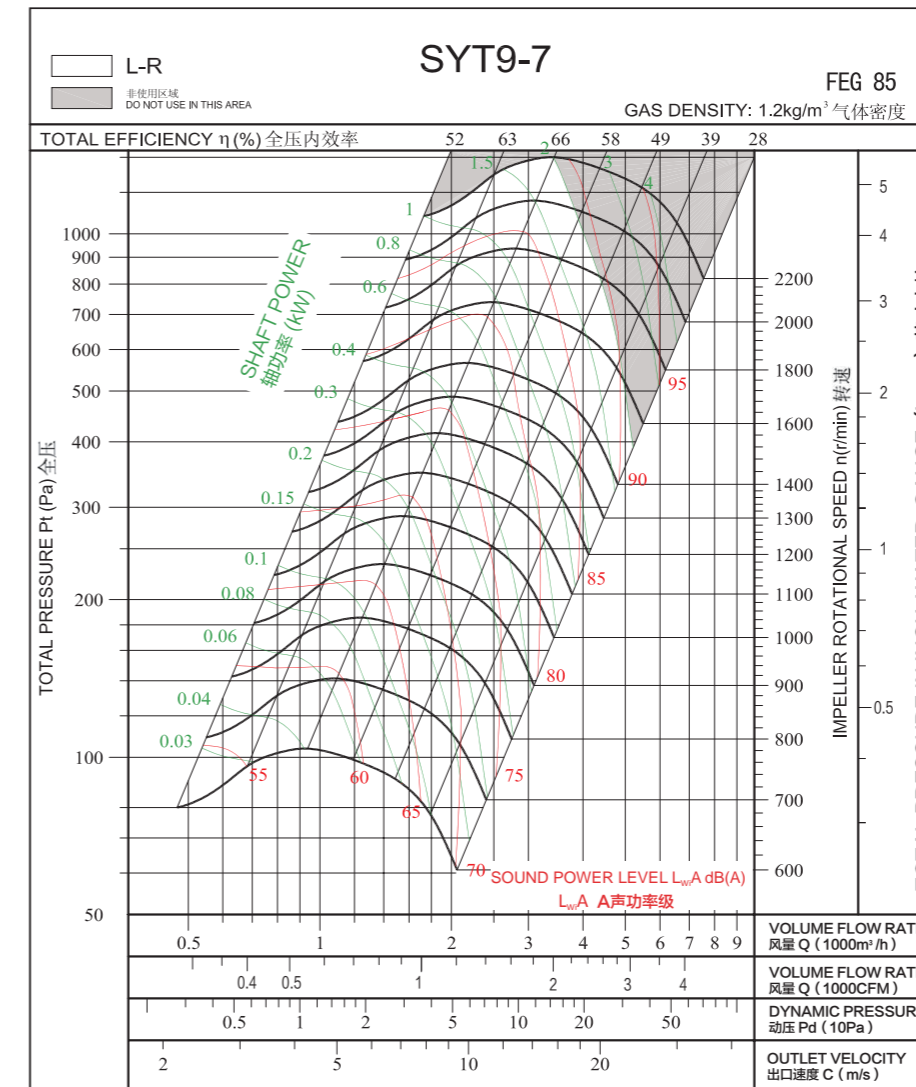
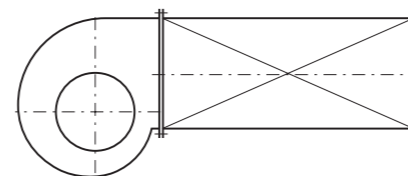

Measured in installation B according to AMCA Standard 210:

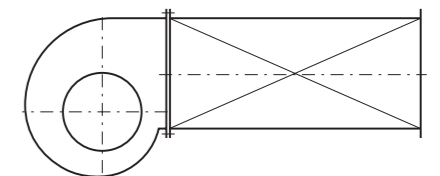



### 技术参数

### Technical Data

Wheel diameter 叶轮直径	D = 9 inch	Fan weight 风机质量	m = 11.4 kg
Moment of inertia 转动惯量	J = 0.034kg·m <sup>2</sup>	Speed limit 极限转速	n <sub>max</sub> = 1800 r/min

### 技术参数

### Technical Data

Wheel diameter 叶轮直径	D = 10 inch	Fan weight 风机质量	m = 12.3 kg
Moment of inertia 转动惯量	J = 0.047 kg·m <sup>2</sup>	Speed limit 极限转速	n <sub>max</sub> = 1800 r/min

### 性能曲线

### Performance Curves

经认证的性能是B类安装：自由入口，管道出口。功率额定值(kW)不包括传输损失。各项性能额定值不包括附属物(附件)的影响。所示A加权声音性能额定值已按AMCA International标准301计算。所示值为安装类型B：自由入口，管道出口的声功率级（入口L<sub>wA</sub>）。

Performance certified is for installation type B: free inlet, ducted outlet. Power rating (kW) does not include transmission losses. Performance ratings do not include the effects of appurtenances (accessories). The A-weighted sound ratings shown have been calculated per AMCA International Standard 301. Values shown are for inlet L<sub>wA</sub> sound power levels for installation type B: free inlet, ducted outlet.

### 性能曲线

### Performance Curves

经认证的性能是B类安装：自由入口，管道出口。功率额定值(kW)不包括传输损失。各项性能额定值不包括附属物(附件)的影响。所示A加权声音性能额定值已按AMCA International标准301计算。所示值为安装类型B：自由入口，管道出口的声功率级（入口L<sub>wA</sub>）。

Performance certified is for installation type B: free inlet, ducted outlet. Power rating (kW) does not include transmission losses. Performance ratings do not include the effects of appurtenances (accessories). The A-weighted sound ratings shown have been calculated per AMCA International Standard 301. Values shown are for inlet L<sub>wA</sub> sound power levels for installation type B: free inlet, ducted outlet.

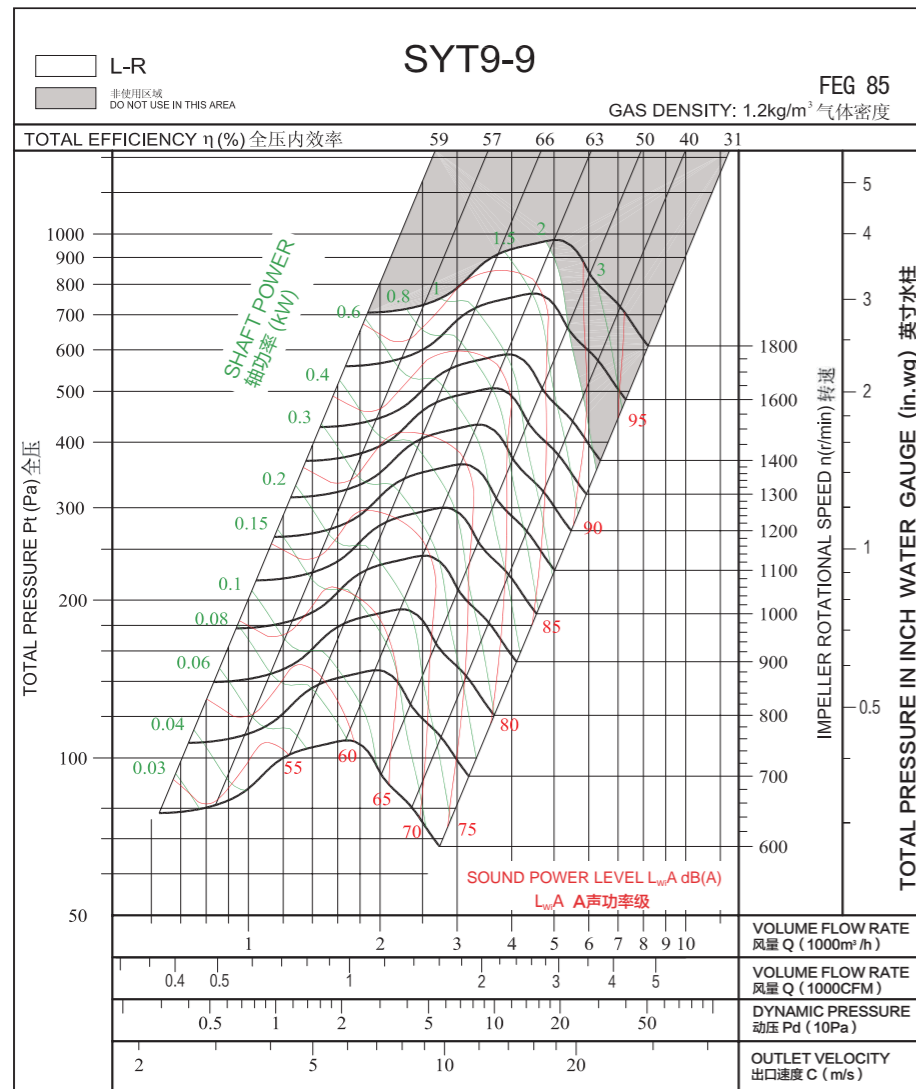

Measured in installation B according to AMCA Standard 210:

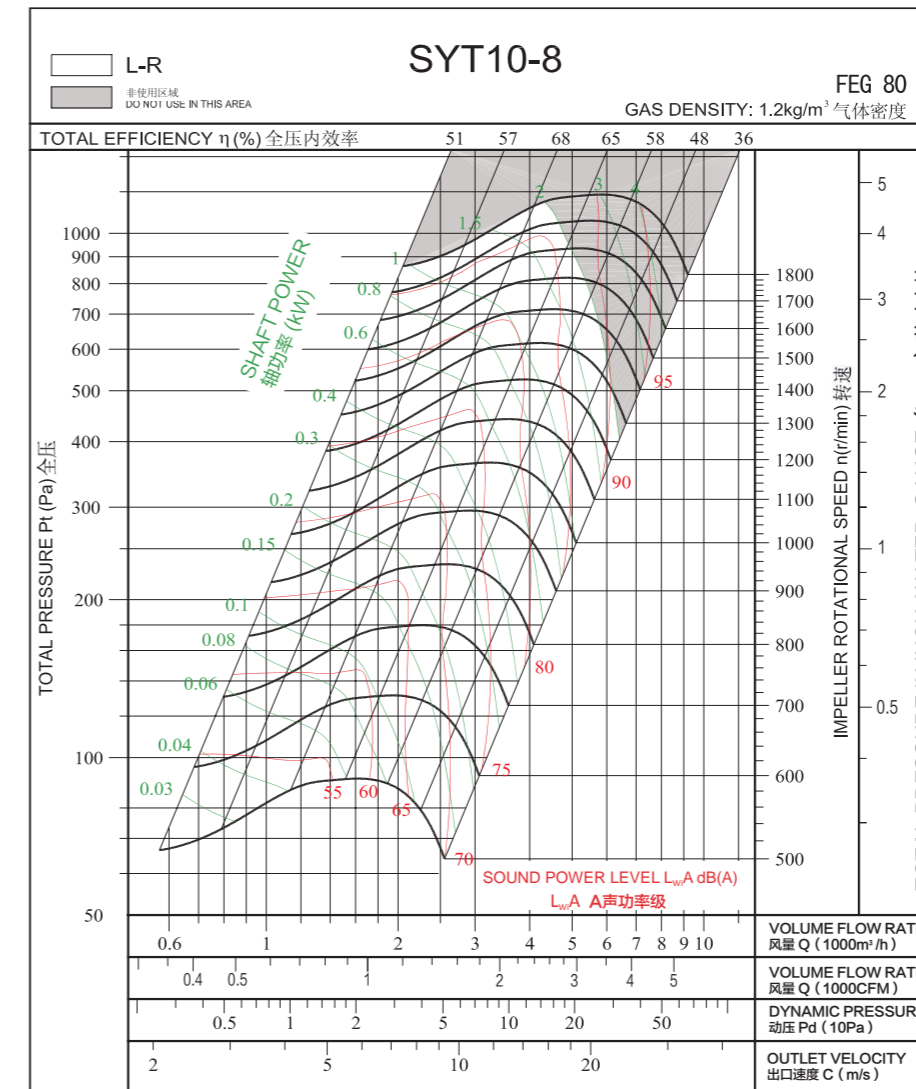
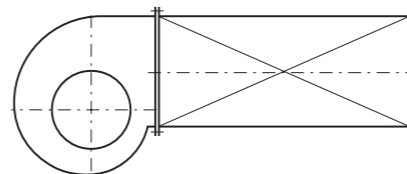

Measured in installation B according to AMCA Standard 210:

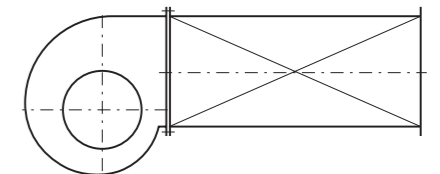

## 技术参数

## Technical Data

Wheel diameter 叶轮直径	D = 10 inch	Fan weight 风机质量	m = 13.2 kg
Moment of inertia 转动惯量	J = 0.055 kg·m <sup>2</sup>	Speed limit 极限转速	n <sub>max</sub> = 1800 r/min

## 技术参数

## Technical Data

Wheel diameter 叶轮直径	D = 12 inch	Fan weight 风机质量	m = 19.1 kg
Moment of inertia 转动惯量	J = 0.097 kg·m <sup>2</sup>	Speed limit 极限转速	n <sub>max</sub> = 1600 r/min

## 性能曲线

## Performance Curves

经认证的性能是B类安装：自由入口，管道出口。功率额定值(kW)不包括传输损失。各项性能额定值不包括附属物(附件)的影响。所示A加权声音性能额定值已按AMCA International标准301计算。所示值为安装类型B：自由入口，管道出口的声功率级（入口L<sub>wA</sub>）。

Performance certified is for installation type B: free inlet, ducted outlet. Power rating (kW) does not include transmission losses. Performance ratings do not include the effects of appurtenances (accessories). The A-weighted sound ratings shown have been calculated per AMCA International Standard 301. Values shown are for inlet L<sub>wA</sub> sound power levels for installation type B: free inlet, ducted outlet.

## 性能曲线

## Performance Curves

经认证的性能是B类安装：自由入口，管道出口。功率额定值(kW)不包括传输损失。各项性能额定值不包括附属物(附件)的影响。所示A加权声音性能额定值已按AMCA International标准301计算。所示值为安装类型B：自由入口，管道出口的声功率级（入口L<sub>wA</sub>）。

Performance certified is for installation type B: free inlet, ducted outlet. Power rating (kW) does not include transmission losses. Performance ratings do not include the effects of appurtenances (accessories). The A-weighted sound ratings shown have been calculated per AMCA International Standard 301. Values shown are for inlet L<sub>wA</sub> sound power levels for installation type B: free inlet, ducted outlet.

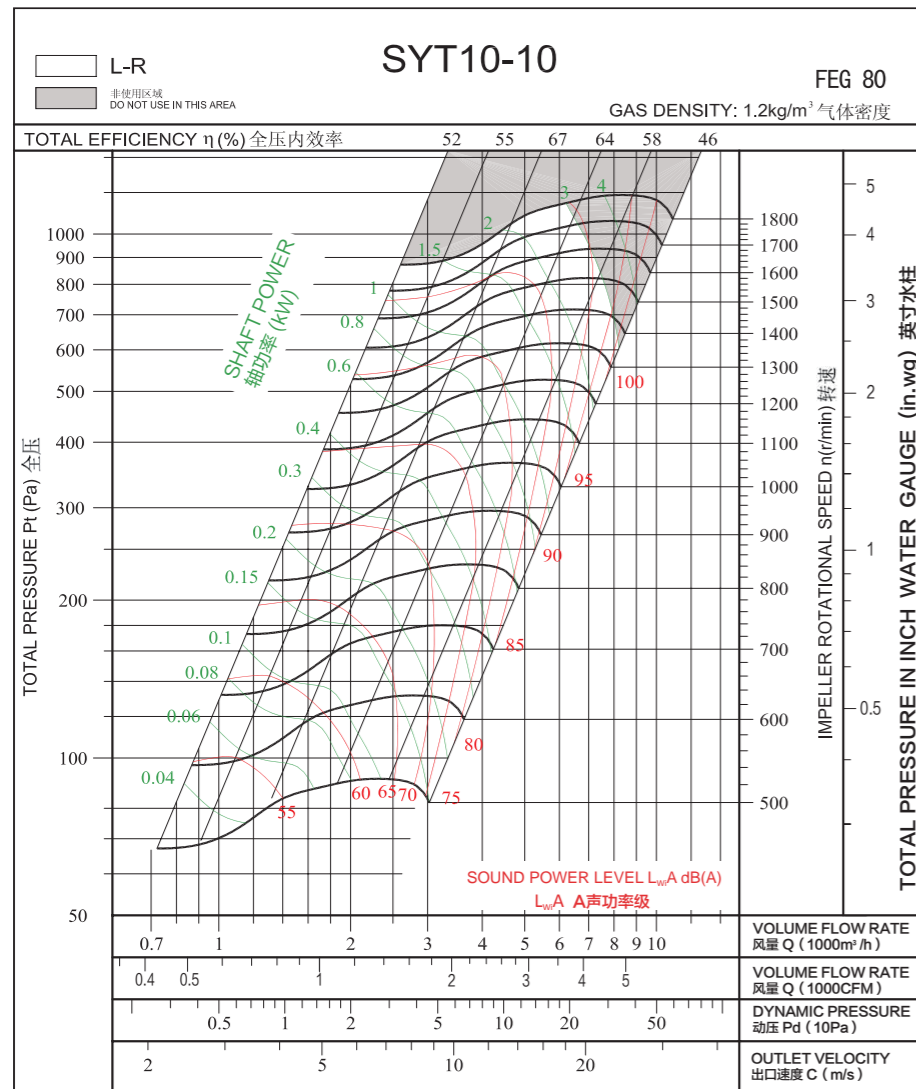

Measured in installation B according to AMCA Standard 210:

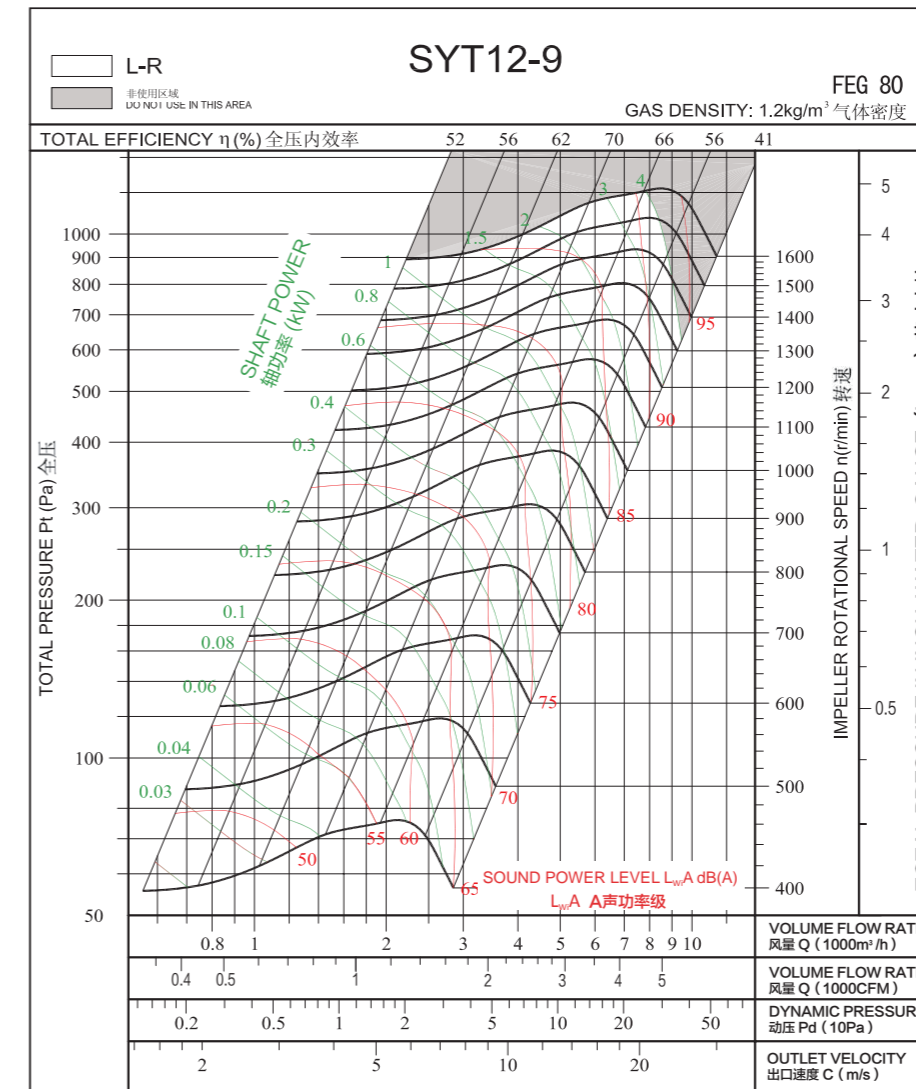
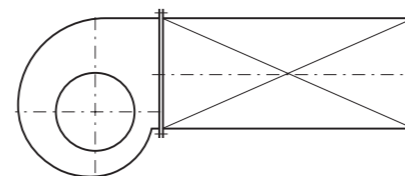

Measured in installation B according to AMCA Standard 210:

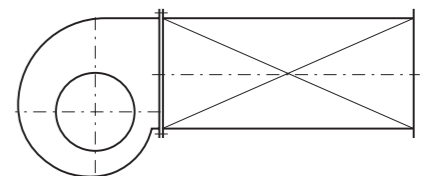

## 技术参数

## Technical Data

Wheel diameter 叶轮直径	D = 12 inch	Fan weight 风机质量	m = 22 kg
Moment of inertia 转动惯量	J = 0.12 kg·m <sup>2</sup>	Speed limit 极限转速	n <sub>max</sub> = 1500 r/min

## 技术参数

## Technical Data

Wheel diameter 叶轮直径	D = 15 inch	Fan weight 风机质量	m = 25.1 kg
Moment of inertia 转动惯量	J = 0.19 kg·m <sup>2</sup>	Speed limit 极限转速	n <sub>max</sub> = 1300 r/min

## 性能曲线

## Performance Curves

经认证的性能是B类安装：自由入口，管道出口。功率额定值(kW)不包括传输损失。各项性能额定值不包括附属物(附件)的影响。所示A加权声音性能额定值已按AMCA International标准301计算。所示值为安装类型B：自由入口，管道出口的声功率级（入口L<sub>wA</sub>）。

Performance certified is for installation type B: free inlet, ducted outlet. Power rating (kW) does not include transmission losses. Performance ratings do not include the effects of appurtenances (accessories). The A-weighted sound ratings shown have been calculated per AMCA International Standard 301. Values shown are for inlet L<sub>wA</sub> sound power levels for installation type B: free inlet, ducted outlet.

## 性能曲线

## Performance Curves

经认证的性能是B类安装：自由入口，管道出口。功率额定值(kW)不包括传输损失。各项性能额定值不包括附属物(附件)的影响。所示A加权声音性能额定值已按AMCA International标准301计算。所示值为安装类型B：自由入口，管道出口的声功率级（入口L<sub>wA</sub>）。

Performance certified is for installation type B: free inlet, ducted outlet. Power rating (kW) does not include transmission losses. Performance ratings do not include the effects of appurtenances (accessories). The A-weighted sound ratings shown have been calculated per AMCA International Standard 301. Values shown are for inlet L<sub>wA</sub> sound power levels for installation type B: free inlet, ducted outlet.

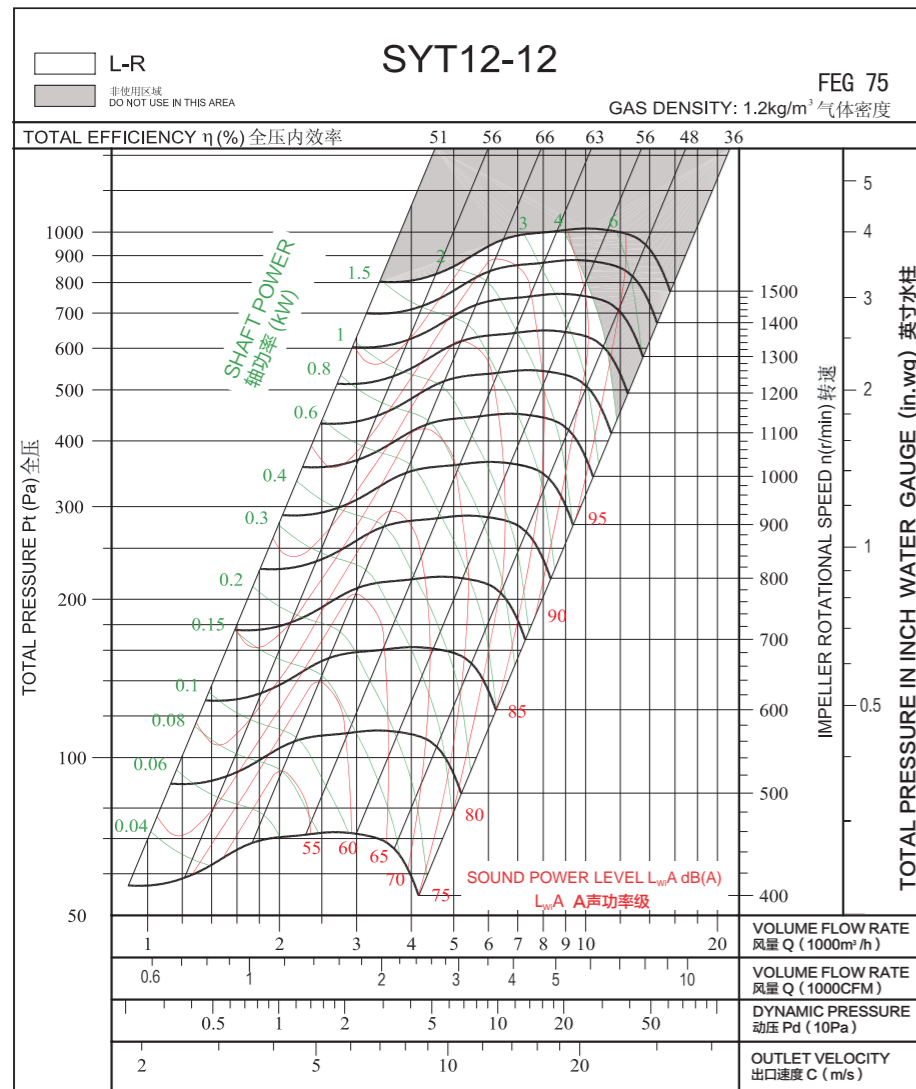

Measured in installation B according to AMCA Standard 210:

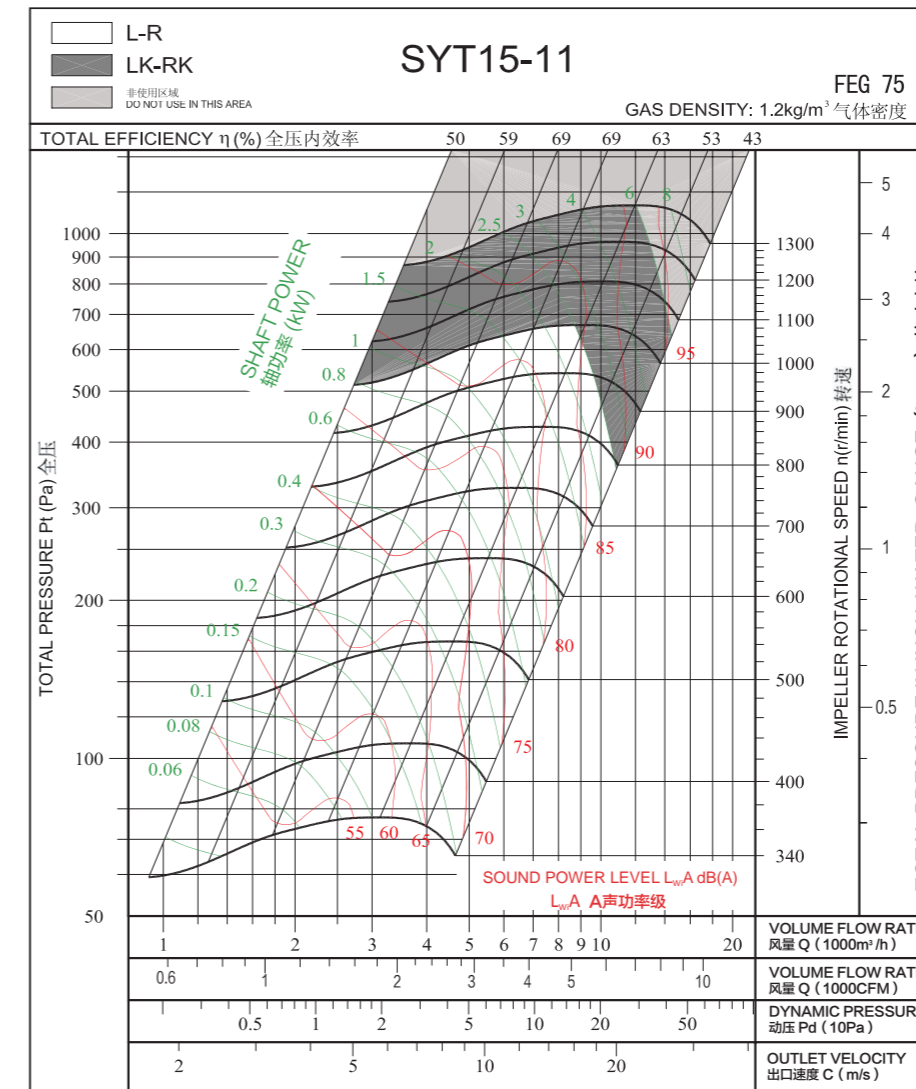
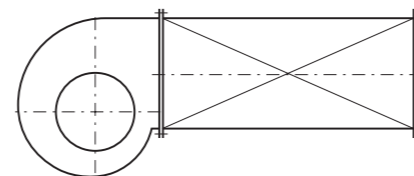

Measured in installation B according to AMCA Standard 210:

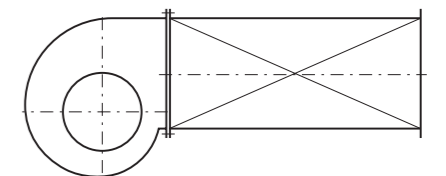



## 技术参数

## Technical Data

Wheel diameter 叶轮直径	D = 15 inch	Fan weight 风机质量	m = 29.4 kg
Moment of inertia 转动惯量	J = 0.23 kg·m <sup>2</sup>	Speed limit 极限转速	n <sub>max</sub> = 1200 r/min

## 技术参数

## Technical Data

Wheel diameter 叶轮直径	D = 18 inch	Fan weight 风机质量	m = 39.6 kg
Moment of inertia 转动惯量	J = 0.46 kg·m <sup>2</sup>	Speed limit 极限转速	n <sub>max</sub> = 1200 r/min

## 性能曲线

## Performance Curves

经认证的性能是B类安装：自由入口，管道出口。功率额定值(kW)不包括传输损失。各项性能额定值不包括附属物(附件)的影响。所示A加权声音性能额定值已按AMCA International标准301计算。所示值为安装类型B：自由入口，管道出口的声功率级（入口L<sub>wA</sub>）。

Performance certified is for installation type B: free inlet, ducted outlet. Power rating (kW) does not include transmission losses. Performance ratings do not include the effects of appurtenances (accessories). The A-weighted sound ratings shown have been calculated per AMCA International Standard 301. Values shown are for inlet L<sub>wA</sub> sound power levels for installation type B: free inlet, ducted outlet.

## 性能曲线

## Performance Curves

经认证的性能是B类安装：自由入口，管道出口。功率额定值(kW)不包括传输损失。各项性能额定值不包括附属物(附件)的影响。所示A加权声音性能额定值已按AMCA International标准301计算。所示值为安装类型B：自由入口，管道出口的声功率级（入口L<sub>wA</sub>）。

Performance certified is for installation type B: free inlet, ducted outlet. Power rating (kW) does not include transmission losses. Performance ratings do not include the effects of appurtenances (accessories). The A-weighted sound ratings shown have been calculated per AMCA International Standard 301. Values shown are for inlet L<sub>wA</sub> sound power levels for installation type B: free inlet, ducted outlet.

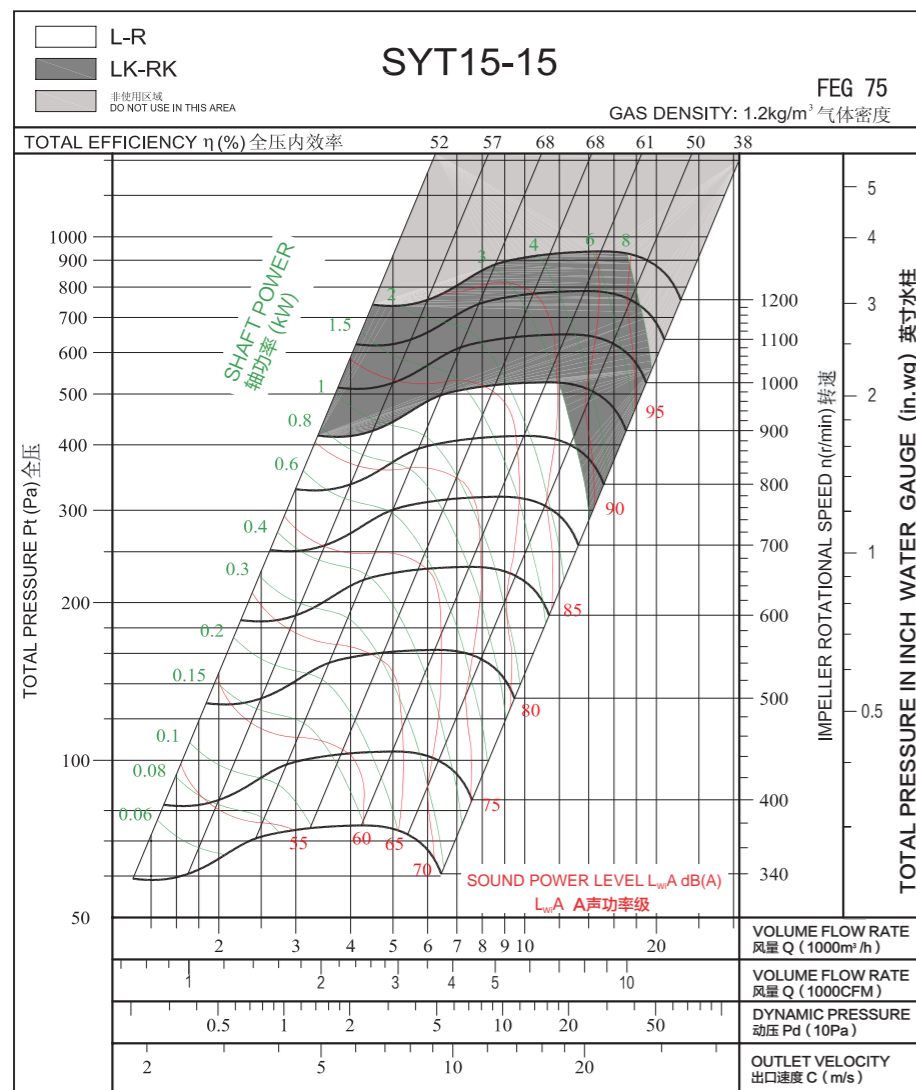

Measured in installation B according to AMCA Standard 210:

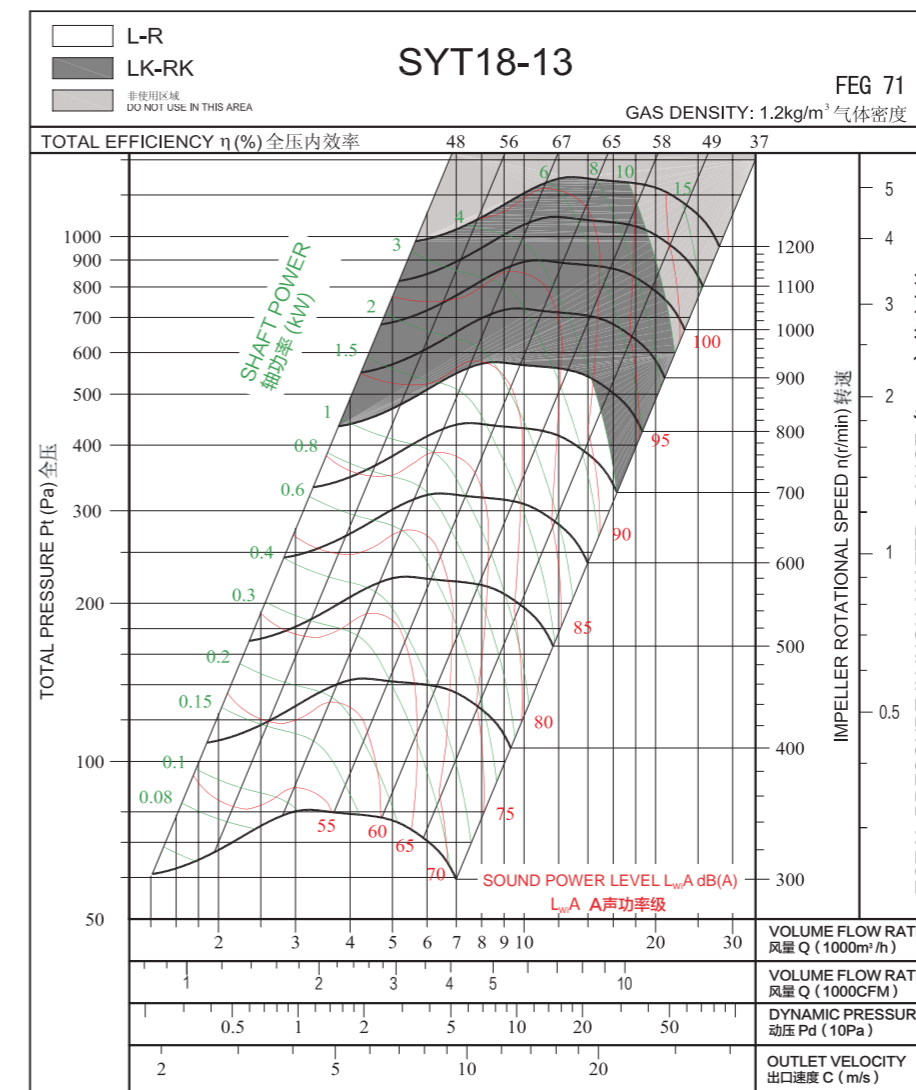
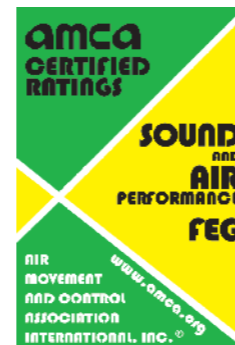
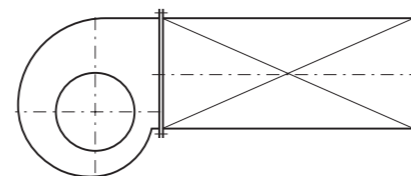

Measured in installation B according to AMCA Standard 210:

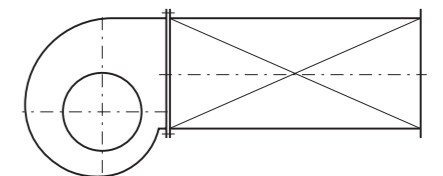

## 技术参数

## Technical Data

Wheel diameter 叶轮直径	D = 18 inch	Fan weight 风机质量	m = 45.5 kg
Moment of inertia 转动惯量	J = 0.57kg·m <sup>2</sup>	Speed limit 极限转速	n <sub>max</sub> = 1100r/min

## 性能曲线

## Performance Curves

经认证的性能是B类安装：自由入口，管道出口。功率额定值(kW)不包括传输损失。各项性能额定值不包括附属物(附件)的影响。所示A加权声音性能额定值已按AMCA International标准301计算。所示值为安装类型B：自由入口，管道出口的声功率级（入口L<sub>wA</sub>）。

Performance certified is for installation type B: free inlet, ducted outlet. Power rating (kW) does not include transmission losses. Performance ratings do not include the effects of appurtenances (accessories). The A-weighted sound ratings shown have been calculated per AMCA International Standard 301. Values shown are for inlet L<sub>wA</sub> sound power levels for installation type B: free inlet, ducted outlet.

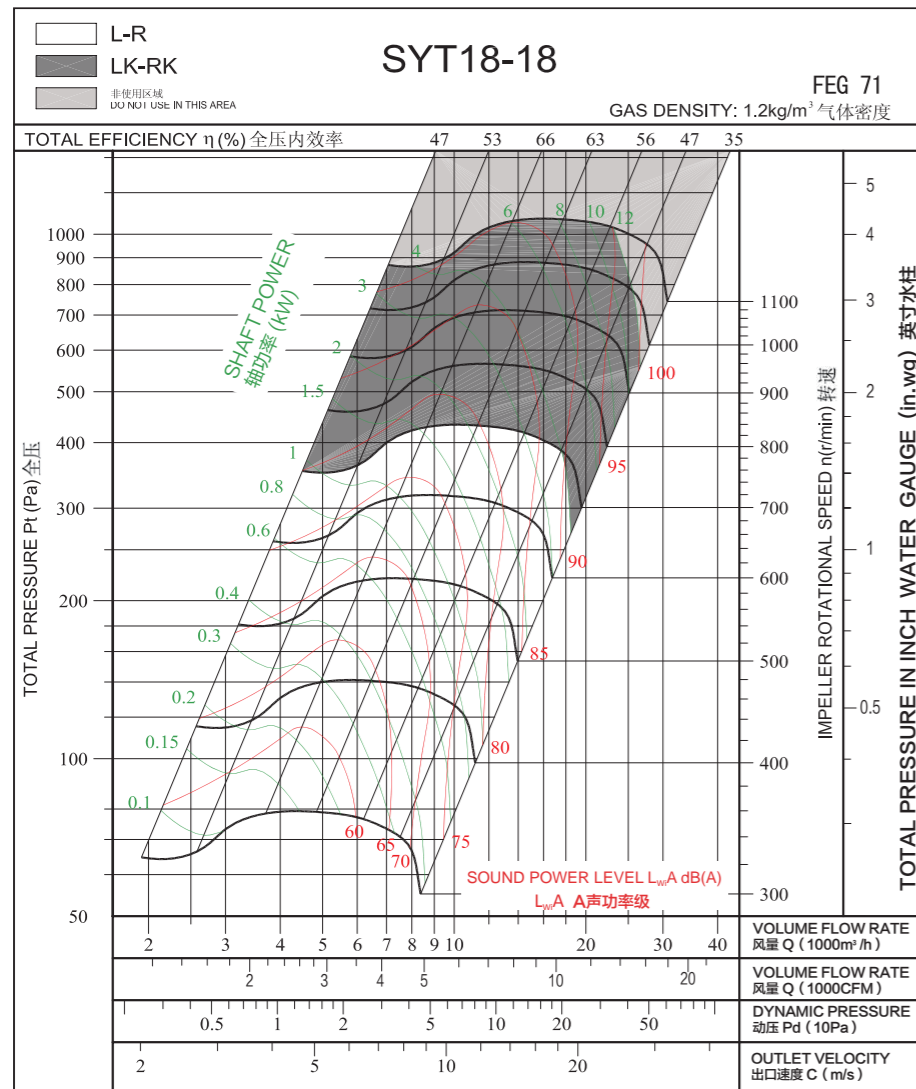

Measured in installation B according to AMCA Standard 210:

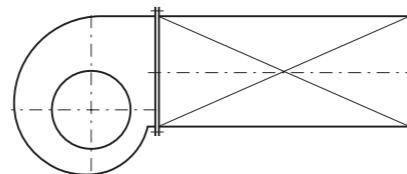

## 出口法兰

## Outlet Flange

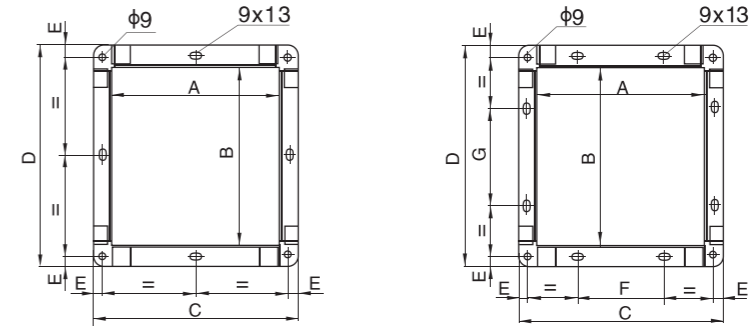

单位: mm

Dim \ Modle	7-7	8-8	9-7	9-9	10-8	10-10	12-9	12-12	15-11	15-15	18-13	18-18
A	259	287	232	298	265	331	309	395	373	471	430	557
B	228	256	262	262	289	289	341	341	404	404	478	478
C	299	327	272	338	321	387	365	451	429	527	486	613
D	268	296	302	302	345	345	397	397	460	460	534	534
E	10	10	10	10	13	13	13	13	13	13	13	13
F	\	\	\	\	\	\	125	150	145	180	160	200
G	\	\	\	\	\	\	140	140	160	160	180	180

## 出口法兰

## Outlet Flange

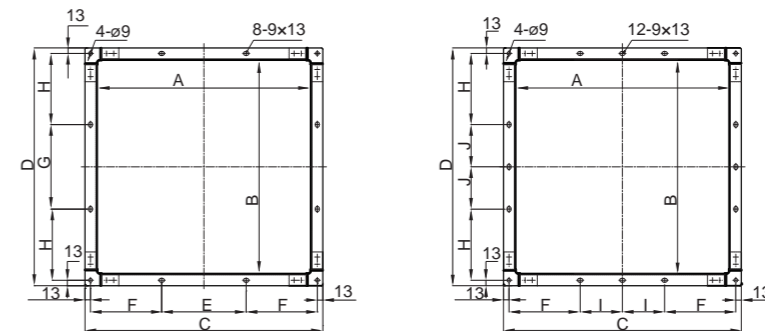

单位: mm

Dim \ Modle	20-15	20-20	22-15	22-22	25-20	25-25	28-20	28-28	30-20	30-28
A	502	630	514	629	664	794	676	870	676	870
B	629	629	695	695	797	797	870	870	936	936
C	558	686	570	748	720	850	732	926	732	926
D	685	685	751	751	853	853	926	926	992	992
E	200	200	250	250	300	300	\	\	\	\
F	166	230	147	236	197	262	153	250	153	250
G	200	200	250	250	300	300	\	\	\	\
H	229.5	229.5	237.5	237.5	263.5	263.5	250	250	283	283
I	\	\	\	\	\	\	200	200	200	200
J	\	\	\	\	\	\	200	200	200	200

**SYT-L(LK)**

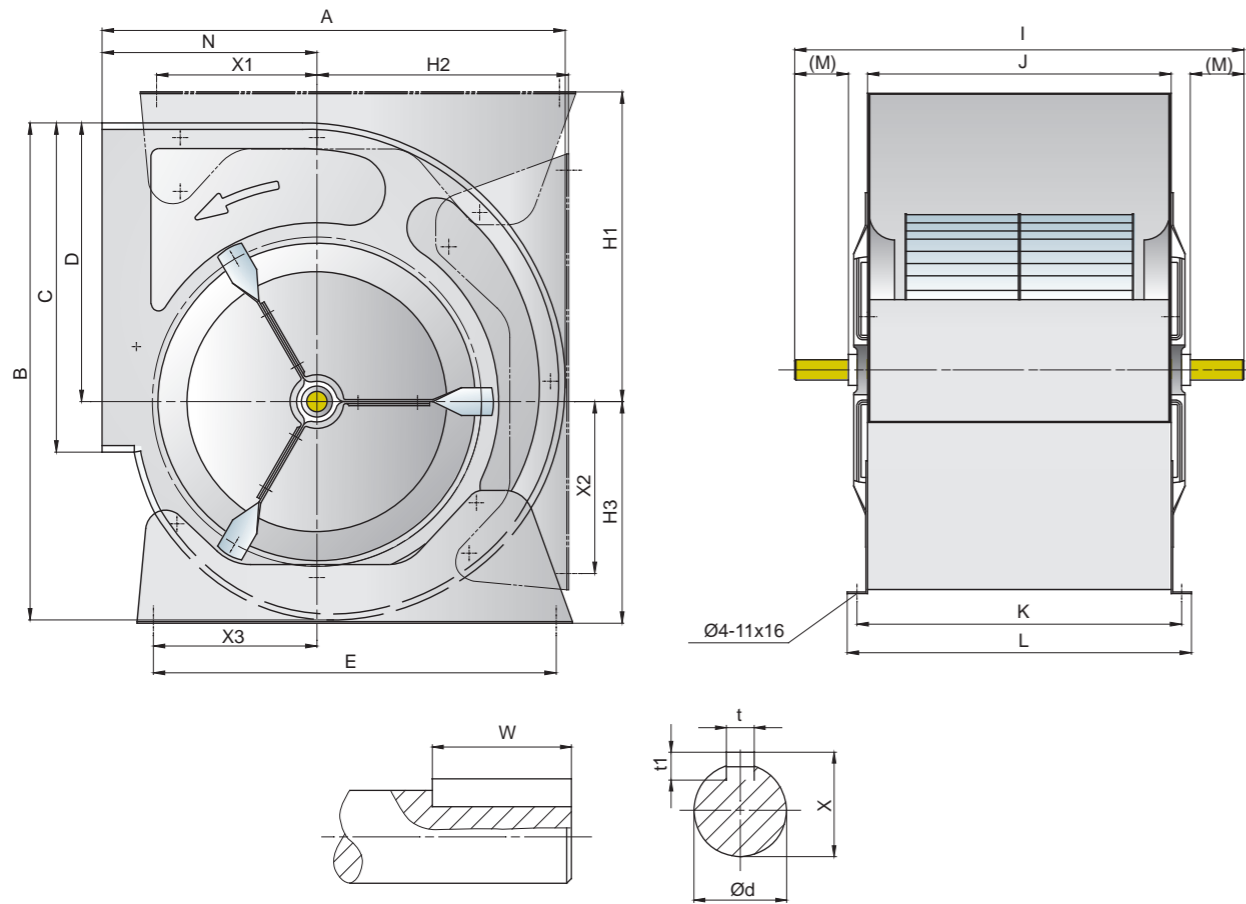

单位: mm

Model	A	B	C	D	E	I	J	K	L	M	N	X	t	t1	W	d	H1	H2	H3	X1	X2	X3
7-7L	312	328	228	192	180	370	259	279	299	32	152	22.5	6	6	30	20	224	164	164	90	90	90
8-8L	346	365	256	216	224	420	287	312	337	43	164	22.5	6	6	40	20	245	184	181	112	112	112
9-7L	380	387	262	215	300	370	232	258	282	45.5	185	22.5	6	6	40	20	253	199	177	119	124	123
9-9L	380	387	262	215	300	447	298	324	348	51	185	22.5	6	6	30	20	253	199	177	119	124	123
10-8L	430	446	289	249	340	409	265	291	315	48.5	203	28	8	7	40	25	287	227	198	136	132	135
10-10L	430	446	289	249	340	490	331	357	381	56	203	28	8	7	55	25	287	227	198	136	132	135
12-9L	492	521	341	294	408	464	309	335	359	54	230	28	8	7	40	25	332	266	232	161	153	161
12-12L	492	521	341	294	408	564	395	421	445	61	230	28	8	7	60	25	332	266	232	161	153	161
15-11L	569	609	404	342	495	552	373	399	423	66	264	28	8	7	50	25	380	309	272	197	211	161
15-11LK	569	609	404	342	495	570	373	399	423	71.8	264	33	8	7	40	30	380	309	272	197	211	201
15-15L	569	609	404	342	495	650	471	497	521	66	264	28	8	7	60	25	380	309	272	197	211	201
15-15LK	569	609	404	342	495	675	471	497	521	75.3	264	33	8	7	65	30	380	309	272	197	211	201
18-13L	684	739	478	415	608	610	430	456	480	66.5	314	28	8	7	65	25	457	376	340	262	283	278
18-13LK	684	739	478	415	608	610	430	456	480	60.6	314	38	10	8	60	35	457	376	340	262	283	278
18-18L	684	739	478	415	608	740	557	583	607	68	314	28	8	7	65	25	457	376	340	262	283	278
18-18LK	684	739	477	415	608	790	557	583	607	87.1	314	38	10	8	70	35	457	376	340	262	283	278

**SYT-R(RK)**

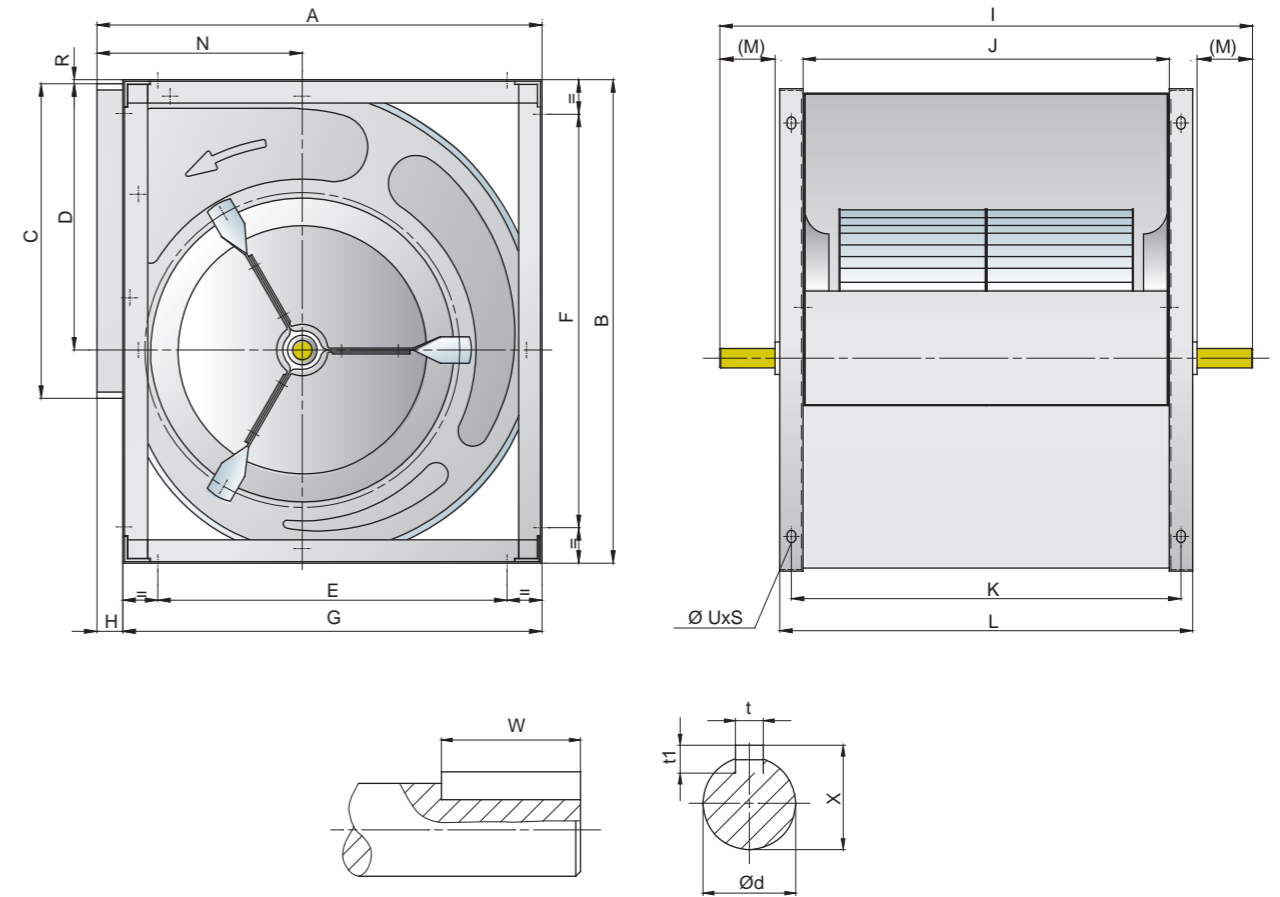

单位: mm

Model	A	B	C	D	E	F	G	H	I	J	K	L	M	N	R	t	t1	W	X	d	UxS
7-7R	323	336	228	192	180	180	294	29	420	259	281	299	57	152	6	6	6	40	22.5	20	9x12
8-8R	348	370	256	216	224	224	314	34	460	287	312	337	63	164	3	6	6	50	22.5	20	9x12
9-7R	385	399	262	215	274	324	349	36	388	232	254	272	54.5	185	6	6	6	40	22.5	20	9x12
9-9R	385	399	262	215	274	324	349	36	460	298	320	338	57.5	185	6	6	6	50	22.5	20	9x12
10-8R	431	455	289	249	330	390	395	36	425	265	287	305	56.5	203	6	8	7	40	28	25	11x16
10-10R	431	455	289	249	330	390	395	36	490	331	353	371	56	203	6	8	7	55	28	25	11x16
12-9R	494	527	341	294	371	443	458	36	490	309	339	369	67	230	3	8	7	50	28	25	11x16
12-12R	494	527	341	294	371	443	458	36	600	395	425	455	79	230	3	8	7	40	28	25	11x16
15-11R	575	619	402	343	449	531	539	36	585	373	403	433	82.5	267	4	8	7	50	28	25	11x16
15-11RK	575	619	402	343	449	531	539	36	625	373	403	433	99.3	267	4	8	7	40	33	30	11x16
15-15R	575	619	402	343	449	531	539	36	685	471	501	531	83.5	267	4	8	7	65	28	25	11x16
15-15RK	575	619	402	343	449	531	539	36	725	471	501	531	100	267	4	8	7	65	33	30	11x16
18-13RK	690	751	478	415	544	641	654	36	666	430	470	510	94.5	314	6	8	7	65	28	25	11x16
18-13R	690	751	478	415	544	641	654	36	666	430	470	510	88.6	314	6	10	8	55	38	35	11x16
18-18R	690	751	478	415	544	641	654	36	790	557	597	637	93	314	6	8	7	65	28	25	11x16
18-18RK	690	751	477	415	544	641	654	36	790	557	597	637	89.8	314	6	10	8	70	38	35	11x16



**SYT-L2**

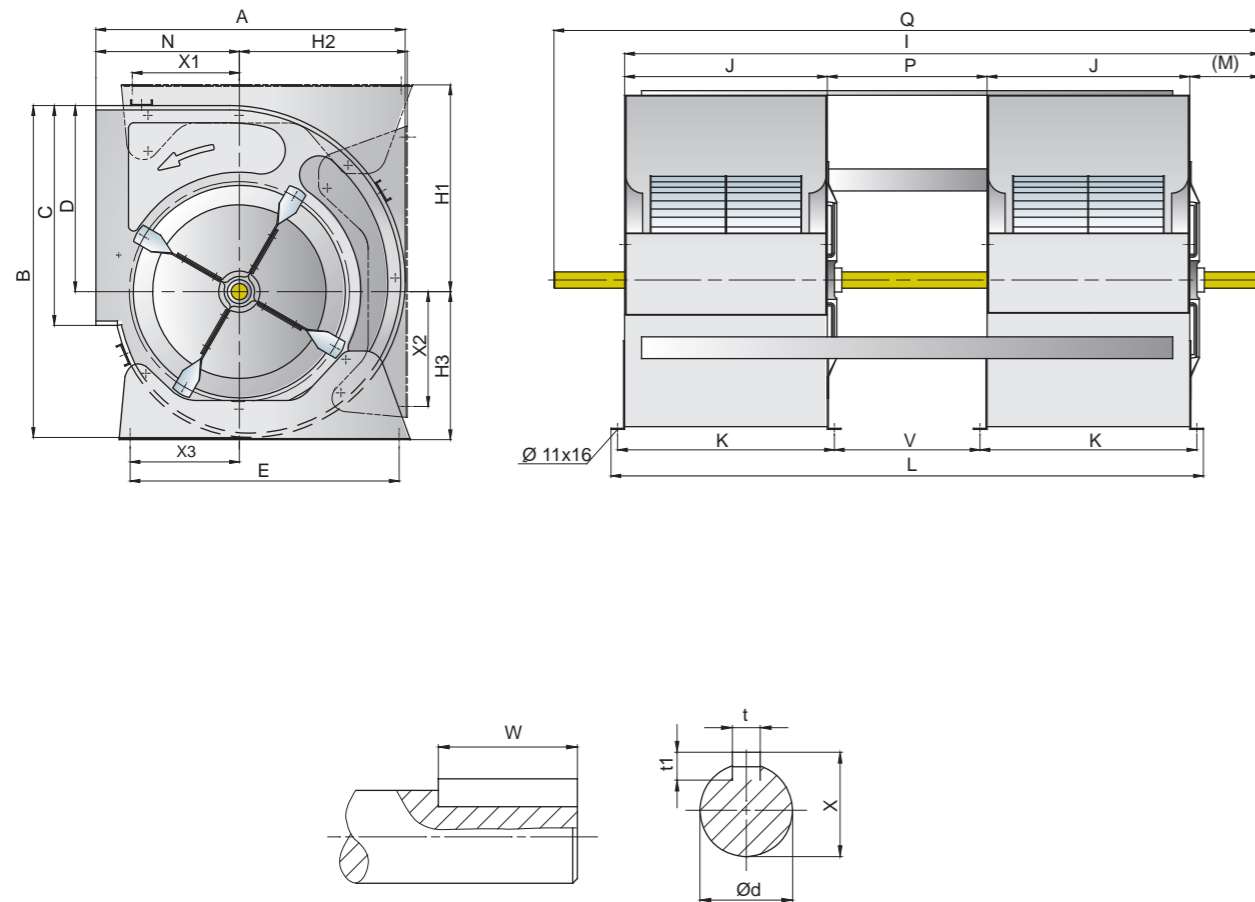

单位: mm

Model	A	B	C	D	E	I	J	K	L	M	N	P	Q	V	X	t	t1	W	d	H1	H	H3	X1	X2	X3
7-7L2	312	328	228	192	180	\	259	279	742	80	152	184	862	164	22.5	6	6	60	20	224	164	164	90	90	90
8-8L2	346	365	256	216	224	\	287	312	838	95	164	214	978	189	22.5	6	6	60	20	245	184	181	112	112	112
9-7L2	380	387	262	215	300	\	232	258	698	90	185	184	828	159	22.5	6	6	60	20	253	199	177	119	124	123
9-9L2	380	387	262	215	300	\	298	324	890	90	185	244	1020	218	28	8	7	60	25	253	199	177	119	124	123
10-8L2	425	443	289	249	340	\	265	291	794	90	203	214	924	188	28	8	7	60	25	287	227	198	136	132	135
10-10L2	425	443	289	249	340	\	331	357	976	90	203	264	1106	238	28	8	7	60	25	287	227	198	136	132	135
12-9L2	492	521	341	294	408	\	309	335	912	110	230	244	1082	218	28	8	7	60	25	332	266	232	161	153	161
12-12L2	492	521	341	294	408	1224	395	421	1164	110	230	324	\	298	33	8	7	70	30	332	266	232	161	153	161
15-11L2	569	609	404	342	495	1170	373	399	1090	130	264	294	\	268	33	8	7	70	30	380	309	272	197	211	201
15-15L2	569	609	404	342	495	1456	471	497	1376	130	264	384	\	358	33	8	7	70	30	380	309	272	197	211	201
18-13L2	684	739	478	415	608	1343	430	454	1253	140	314	343	\	319	38	10	8	90	35	457	376	340	262	283	278
18-18L2	684	739	478	415	608	1702	557	581	1622	130	314	458	\	434	38	10	8	90	35	457	376	340	262	283	278

注: SYT7-7至SYT12-9系列风机为双出轴 / SYT12-12至SYT18-18系列风机为单出轴

**SYT-R2**

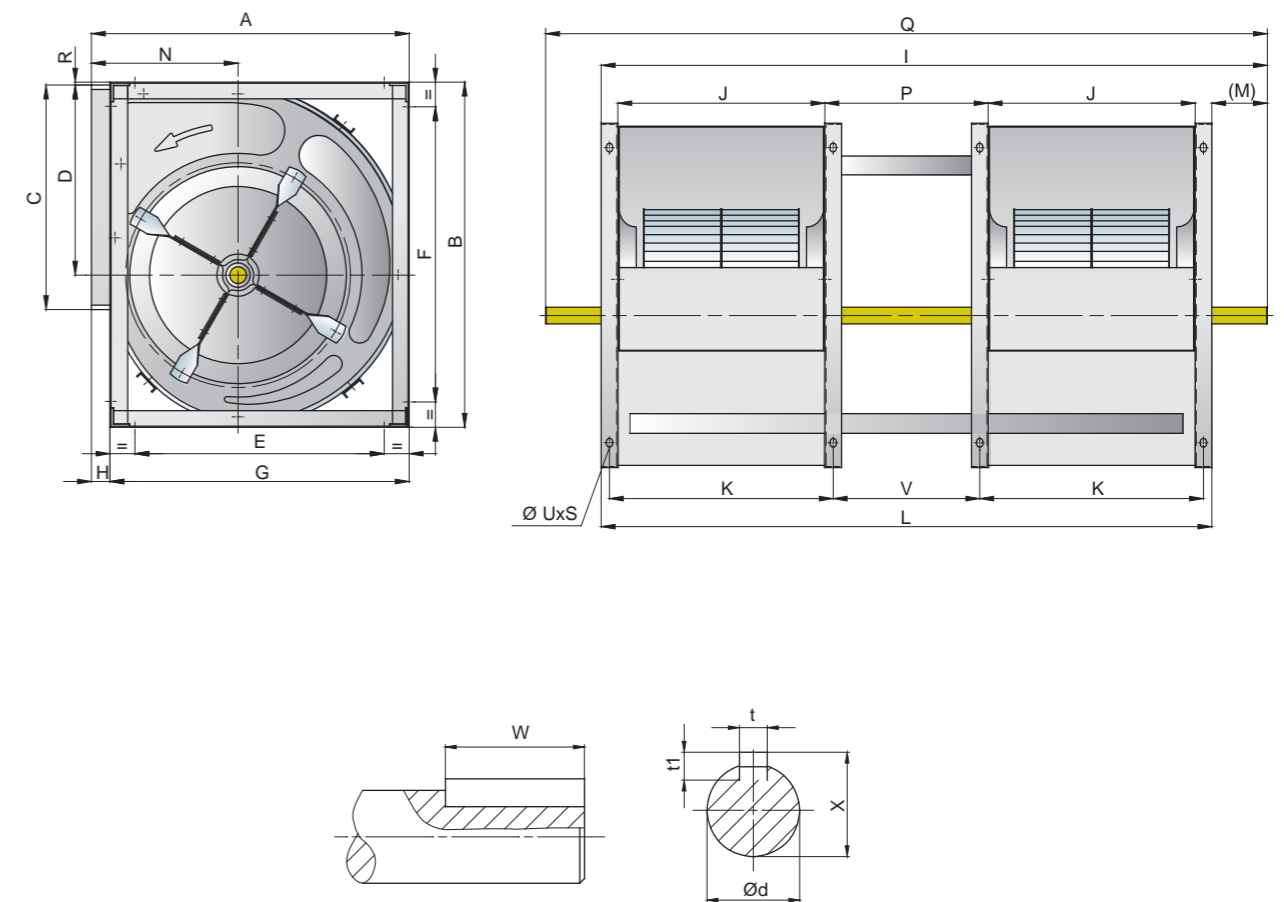

单位: mm

Model	A	B	C	D	E	F	G	H	I	J	K	L	M	N	P	Q	V	R	t	t1	W	X	d	UxS
7-7R2	323	336	228	192	180	180	294	29	\	259	281	742	70	152	184	882	162	6	6	6	60	22.5	20	9x12
8-8R2	348	370	256	216	224	224	314	37	\	287	312	838	70	164	214	978	189	3	6	6	60	22.5	20	9x12
9-7R2	385	399	262	215	274	324	349	36	\	232	254	688	70	185	184	828	162	6	6	6	60	22.5	20	9x12
9-9R2	385	397	262	215	274	324	349	36	\	298	320	880	70	185	244	1020	222	6	8	7	60	28	25	9x12
10-8R2	431	455	289	249	330	390	395	36	\	265	287	784	70	203	214	924	192	7	8	7	60	28	25	11x16
10-10R2	431	455	289	249	330	390	395	36	\	331	353	966	70	203	264	1106	242	7	8	7	60	28	25	11x16
12-9R2	494	527	341	294	371	443	458	36	\	309	339	918	82	230	244	1082	214	3	8	7	60	28	25	11x16
12-12R2	494	527	341	294	371	443	458	36	1274	395	425	1174	100	230	324	\	294	3	8	7	60	33	30	11x16
15-11R2	575	619	402	343	449	531	539	36	1200	373	403	1100	100	266.7	294	\	264	4	8	7	70	33	30	11x16
15-15R2	575	619	402	343	449	531	539	36	1486	471	501	1386	100	266.7	384	\	354	4	8	7	70	33	30	11x16
18-13R2	690	751	478	415	544	641	654	36	1383	430	470	1283	100	314	343	\	303	6	10	8	90	38	35	11x16
18-18R2	690	751	478	415	544	641	654	36	1752	557	597	1652	100	314	458	\	418	6	10	8	90	38	35	11x16

注: SYT7-7至SYT12-9系列风机为双出轴 / SYT12-12至SYT18-18系列风机为单出轴

SYT-L(LK)

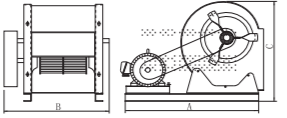
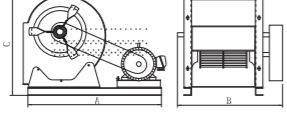
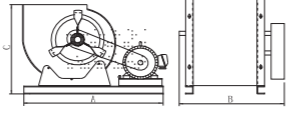
		0°			90°			180°		
左旋 LG Left Hand										
右旋 RD Right Hand										
型号 Model	电机机座型号 Motor Frame Size	A	B	C	A	B	C	A	B	C
7-7	63	690	400	410	690	400	366	690	400	406
	71	690	400	410	690	400	366	690	400	406
	80	690	400	410	690	400	366	690	400	406
	90	690	400	410	690	400	366	690	400	406
8-8	63	710	450	443	710	450	378	710	450	447
	71	710	450	443	710	450	378	710	450	447
	80	710	450	443	710	450	378	710	450	447
	90	710	450	443	710	450	378	710	450	447
9-7	71	810	400	474	810	400	434	810	400	444
	80	810	400	474	810	400	434	810	400	444
	90	810	400	474	810	400	434	810	400	444
	100	810	400	474	810	400	434	810	400	444
	/	/	/	/	/	/	/	/	/	/
9-9	71	810	439	474	810	439	434	810	439	444
	80	810	439	474	810	439	434	810	439	444
	90	810	439	474	810	439	434	810	439	444
	100	810	439	474	810	439	434	810	439	444
	/	/	/	/	/	/	/	/	/	/
10-8	71	850	465	531	850	465	480	850	465	497
	80	850	465	531	850	465	480	850	465	497
	90	850	465	531	850	465	480	850	465	497
	100	850	465	531	850	465	480	850	465	497
	/	/	/	/	/	/	/	/	/	/
10-10	80	860	490	531	860	490	480	7	490	497
	90	860	490	531	860	490	480	8	490	497
	100	860	490	531	860	490	480	8	490	497
	112	860	490	531	860	490	480	9	490	497

SYT-L(LK)

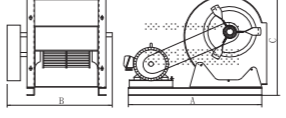
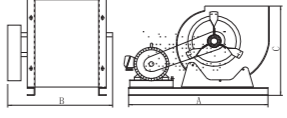
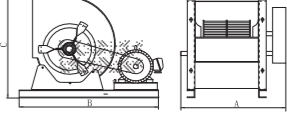
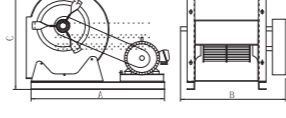
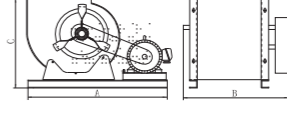
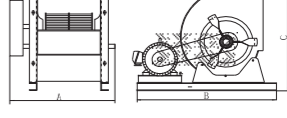
		0°			90°			180°		
左旋 LG Left Hand										
右旋 RD Right Hand										
型号 Model	电机机座型号 Motor Frame Size	A	B	C	A	B	C	A	B	C
12-9	80	960	494	610	960	494	546	960	494	576
	90	960	494	610	960	494	546	960	494	576
	100	960	494	610	960	494	546	960	494	576
	112	960	494	610	960	494	546	960	494	576
	132	960	494	610	960	494	546	960	494	576
12-12	80	960	580	610	960	580	546	960	580	576
	90	960	580	610	960	580	546	960	580	576
	100	960	580	610	960	580	546	960	580	576
	112	960	580	610	960	580	546	960	580	576
	132	960	580	610	960	580	546	960	580	576
15-11	80	1070	582	687	1070	582	613	1070	582	664
	90	1070	582	687	1070	582	613	1070	582	664
	100	1070	582	687	1070	582	613	1070	582	664
	112	1070	582	687	1070	582	613	1070	582	664
	132	1070	582	687	1070	582	613	1070	582	664
15-15	80	1080	680	687	1080	680	613	1080	680	664
	90	1080	680	687	1080	680	613	1080	680	664
	100	1080	680	687	1080	680	613	1080	680	664
	112	1080	680	687	1080	680	613	1080	680	664
	132	1080	680	687	1080	680	613	1080	680	664
18-13	90	1240	640	821	1240	640	730	1240	640	805
	100	1240	640	821	1240	640	730	1240	640	805
	112	1240	640	821	1240	640	730	1240	640	805
	132	1240	640	821	1240	640	730	1240	640	805
	160	1240	640	821	1240	640	730	1240	640	805
18-18	90	1250	770	821	1250	770	730	1250	770	805
	100	1250	770	821	1250	770	730	1250	770	805
	112	1250	770	821	1250	770	730	1250	770	805
	132	1250	770	821	1250	770	730	1250	770	805

SYT-R(RK)

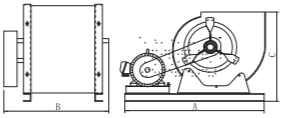
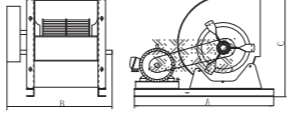
		0°			90°			180°		
左旋 LG Left Hand										
右旋 RD Right Hand										
型号 Model	电机机座型号 Motor Frame Size	A	B	C	A	B	C	A	B	C
7-7	63	690	398	386	690	398	373	690	398	386
	71	690	398	386	690	398	373	690	398	386
	80	690	398	386	690	398	373	690	398	386
	90	690	398	386	690	398	373	690	398	386
8-8	63	710	484	420	710	484	393	710	484	420
	71	710	484	420	710	484	393	710	484	420
	80	710	484	420	710	484	393	710	484	420
	90	710	484	420	710	484	393	710	484	420
9-7	71	810	418	449	810	418	435	810	418	449
	80	810	418	449	810	418	435	810	418	449
	90	810	418	449	810	418	435	810	418	449
	100	810	418	449	810	418	435	810	418	449
	/	/	/	/	/	/	/	/	/	/
9-9	71	810	490	449	810	490	435	810	490	449
	80	810	490	449	810	490	435	810	490	449
	90	810	490	449	810	490	435	810	490	449
	100	810	490	449	810	490	435	810	490	449
	/	/	/	/	/	/	/	/	/	/
10-8	71	850	455	505	850	455	481	850	455	505
	80	850	455	505	850	455	481	850	455	505
	90	850	455	505	850	455	481	850	455	505
	100	850	455	505	850	455	481	850	455	505
	/	/	/	/	/	/	/	/	/	/
10-10	80	860	520	505	860	520	481	860	520	505
	90	860	520	505	860	520	481	860	520	505
	100	860	520	505	860	520	481	860	520	505
	112	860	520	505	860	520	481	860	520	505

SYT-R(RK)

		0°			90°			180°		
左旋 LG Left Hand										
右旋 RD Right Hand										
型号 Model	电机机座型号 Motor Frame Size	A	B	C	A	B	C	A	B	C
12-9	80	960	525	583	960	525	547	960	525	583
	90	960	525	583	960	525	547	960	525	583
	100	960	525	583	960	525	547	960	525	583
	112	960	525	583	960	525	547	960	525	583
	132	960	525	583	960	525	547	960	525	583
12-12	80	960	615	583	960	615	547	960	615	583
	90	960	615	583	960	615	547	960	615	583
	100	960	615	583	960	615	547	960	615	583
	112	960	615	583	960	615	547	960	615	583
	132	960	615	583	960	615	547	960	615	583
15-11	80	1070	615	661	1070	615	615	1070	615	661
	90	1070	615	661	1070	615	615	1070	615	661
	100	1070	615	661	1070	615	615	1070	615	661
	112	1070	615	661	1070	615	615	1070	615	661
	132	1070	615	661	1070	615	615	1070	615	661
15-15	80	1080	715	661	1080	715	615	1080	715	661
	90	1080	715	661	1080	715	615	1080	715	661
	100	1080	715	661	1080	715	615	1080	715	661
	112	1080	715	661	1080	715	615	1080	715	661
	132	1080	715	661	1080	715	615	1080	715	661
18-13	90	1240	696	791	1240	696	730	1240	696	791
	100	1240	696	791	1240	696	730	1240	696	791
	112	1240	696	791	1240	696	730	1240	696	791
	132	1240	696	791	1240	696	730	1240	696	791
	160	1240	696	791	1240	696	730	1240	696	791
18-18	90	1250	820	791	1250	820	730	1250	820	791
	100	1250	820	791	1250	820	730	1250	820	791
	112	1250	820	791	1250	820	730	1250	820	791
	132	1250	820	791	1250	820	730	1250	820	791
	160	1250	820	791	1250	820	730	1250	820	791



SYT系列风机运行极限

SYT Series Fan Operational Limits

			7-7	8-8	9-7	9-9	10-8	10-10	12-9	12-12	15-11	15-15	18-13	18-18
极限吸收功率 Max.Absorbed Power	L-R	Kw	1	1.5	2	2	2	3	4	4	2.5	3	4	4
	LK-RK	Kw	/	/	/	/	/	/	/	/	6	8	10	12
	L2-R2	Kw	2	3	4	4	4	6	8	8	12	16	20	24
极限转速 Max.Speed	L-R	rmp	2200	2200	2200	1800	1800	1800	1600	1500	1000	900	800	700
	LK-RK	rmp	/	/	/	/	/	/	/	/	1300	1200	1200	1100
	L2-R2	rmp	2200	2200	2200	1800	1800	1800	1600	1500	1300	1200	1200	1100
极限温度 (最低-20°C) Air Temperature Limits (Min-20°C)	L-R	Max.°C	85	85	85	85	85	85	85	85	85	85	85	85
	L2-R2	Max.°C	85	85	85	85	85	85	85	85	85	85	85	85
轴承额定动载荷 Bearing Dynamic Load	L-R	N	12800	12800	12800	12800	14000	14000	14000	14000	14000	14000	14000	14000
	LK-RK	N	/	/	/	/	/	/	/	/	19500	19500	25700	25700
	L2-R2	N	12800	12800	12800	12800	14000	1400	14000	19500	19500	19500	25700	25700
风机质量 Fan Weight	L	Kg	6	7	8	9.5	10	11	15.2	18.2	21.2	24.7	32.4	39.6
	R	Kg	8.5	9.5	10.2	11.4	12.3	13.2	19.1	22	25.1	29.4	39.6	45.5
	LK	Kg	/	/	/	/	/	/	/	/	24.5	28.2	38.6	45.8
	RK	Kg	/	/	/	/	/	/	/	/	28.5	32.8	45.8	51.7
	L2	Kg	14	15.6	17.9	21.7	22.2	25.3	33.9	40.6	47.6	54.3	69.3	84.6
	R2	Kg	20	24	25.8	29.7	29.7	34.1	50	56	63	74.8	100.1	116.3

SYD 系列离心式空调风机

Centrifugal Ventilators

浙江亿利达风机股份有限公司特此证明，此处所示 SYD 系列离心风机获得了加盖 AMCA 印章的授权。所示额定值系根据 AMCA 出版物 211 和 AMCA 出版物 311 所进行测试和程序确定，并符合 AMCA 认证额定值计划的要求。

这里描述的所有离心风机都已经取得了 AMCA 印章，他们的认证数据见第 065 页到 079 页。

Zhejiang Yilida Ventilator Co.,Ltd. certifies that the SYD Series fans shown herein are licensed to bear the AMCA Seal. The ratings shown are based on tests and procedures performed in accordance with AMCA Publication 211 and AMCA Publication 311 and comply with the requirements of the AMCA Certified Ratings Program.

All the Centrifugal Fans described herein are licensed to bear the AMCA Seal, and their certified ratings are shown on pages 065 through 079.



本样本中所述的风机特性,如尺寸、性能参数等,本公司保留更改的权利,恕不另行通知;如有不明之处,请来电询问。

This fan features described in the sample, such as size, performance parameters, the Company reserves the right to change without notice; if unknown place, please call us.

## 概述

SYD 系列离心式空调风机采用国际同类产品先进技术自行开发生产，通过了 AMCA 国际认证并取得 AMCA 印章。该样本中列出的 15 种规格风机，流量范围从 1000m<sup>3</sup>/h-100000m<sup>3</sup>/h。SYD 系列风机采用前向多翼叶轮，具有通用性强、效率高、噪音低、耗能少等特点。是各类中央空调机组及其他暖通空调、净化、通风等设备理想的配套产品。

## Summary

The SYD Series of centrifugal air conditioning fan was developed with advanced technologies. They are licensed to bear the AMCA Seal for air performance, sound, and FEG. The SYD Series includes 15 models as described in this catalogue. The volume flow of the SYD Series ranges from 1,000m<sup>3</sup>/h to 100,000m<sup>3</sup>/h. Some of the features and characteristics of these fans are: forward impeller blades, a wide range of applications, high efficiency, low noise, and low power consumption. These fans are ideal for use in central air conditioning systems, in purifiers. They are also suitable for use in a variety of other ventilation applications.

## 命名方式

## Nomenclature

SYD 200 L

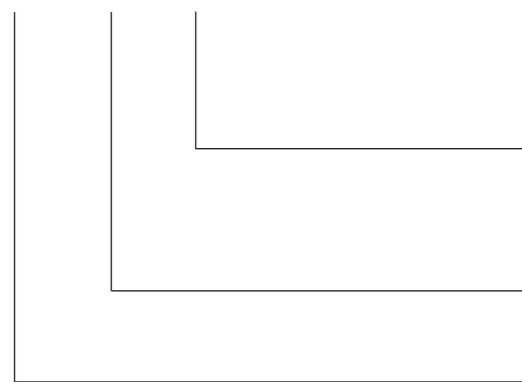

结构型式  
L,R 型(基本型)    **Construction type**  
Type L, R (Basic Model)  
K 型(加强型)    **Type K (Heavy Duty Model)**

叶轮直径(mm)  
**Diameter of impeller (mm)**

前向离心风机系列代号  
**Fan series with forward curved blades**

## 产品型式

## Product Features

### 1、旋向

SYD 系列风机可分为左旋(LG)和右旋(RD)两种旋转方式，从风机皮带轮一端正视，叶轮顺时针旋转的称为右旋风机，逆时针旋转的称为左旋风机。

### 1. Rotation

SYD series fans have two direction of rotations, left-hand rotation (LG) and right-hand rotation (RD); Viewing from drive side, if the impeller rotates clockwise, it is left hand (LG) rotation. If the impeller rotates counter clockwise, it is right-hand (RD).

## 2、出风口方向

## 2. Discharge Direction

SYD 系列出风口可按图 1 所示制成 0°、90°、180°、270° 四种出风方向。

As shown in Fig1, SYD Series ventilator can be constructed in four discharge directions: 0°, 90°, 180°, and 270°.

图1(Fig 1)

	0°	90°	180°	270°
左旋 LG Left Hand				
右旋 RD Right Hand				

## 3、结构形式

## 3. Type of construction

SYD 系列风机可按图 2 所示制成 L 型、R 型、K 型、R2 型、K2 型。

As shown in Fig 2, SYD series ventilators can be divided into Category L, R, K Category R2, K2.

图2(Fig 2)

风机类型 Fan Type	机号 Fan Size	风机示意图 Fan Diagram	轴承实物图 Bearing Type
L 型 TYPE L	200-250		
R 型 TYPE R	200-710		
K 型 TYPE K	200-1000		
R2 型 TYPE R2	200-500		
K2 型 TYPE K2	200-500		

## 产品结构

SYD 系列风机主要由机壳、叶轮、框架、轴承及轴构成。出口法兰(为可选件)。

### 1、机壳

机壳采用热镀锌钢板制造,侧板具有符合空气动力的外形,进风口整体拉伸成型,蜗板采用点焊或“Pittsburg seam locking”的连接方式与侧板连成一体。

### 2、叶轮

前向多翼叶轮采用优质热镀锌钢板制成,叶片设计成符合空气动力学的特定形状,使得效率最高,噪声最低。叶片用铆爪固定在中盘及端圈上,在最大功率连续运转时,叶轮将具备足够的刚度。所有叶轮进行静平衡和动平衡测试,内控精度达到 G2.5 级 (ANSI/AMCA 204-05)。

### 3、框架

L、R 型风机框架采用热镀锌钢板剪切、折弯制成, TOX 连接保证了所需的尺寸精度和应有的刚度; K 型风机框架由角钢和扁钢冷弯焊接制成,轴承安装位进行对称铣平面加工,表面喷塑处理,以保证足够的刚度和强度,同时保证安装轴和轴承的同心度。

### 4、轴承

SYD 系列风机均采用优质滚珠轴承,并根据噪声最低来选择轴承型号; L/R 型风机的轴承安装在轴承支架上,并设有防振垫圈,该轴承已预先加润滑油并自动对中,免维护; K 型风机则采用带座偏心套轴承。轴承设计寿命为  $L_{10} \geq 100000$  小时。

### 5、轴

风机轴采用 40Cr 低合金钢,经车、调质热处理、磨削制成,强度高,挠度小,严格控制轴径尺寸公差及形位公差,每根轴均经过涂覆防锈处理。轴尺寸设计应满足第一临界转速至少为风机最大运行转速的 1.4 倍。

### 6、出风口法兰

法兰采用热镀锌钢板制成,法兰与蜗壳的连接采用 TOX 免焊工艺,外观精美,并具备足够的刚度与强度。

## Construction of Product

SYD series fans are mainly constructed of housing, impeller, frame, bearing and shaft. Outlet flange (is optional) .

### 1. Housing

The housing is made of hot galvanized steel sheet. The side plates include inlets cones that are designed with the best aerodynamics for inlet condition. The scroll is fixed to the side plates by spot welding or "Pittsburg seam locking".

### 2. Impeller

Forward curved impeller is constructed of high-grade hot galvanized steel sheet with the advanced aerodynamics profile to achieve the highest efficiency and the lowest noise level. The impeller is fixed on the center plate and on the end ring with riveting grippres. The impeller is constructed with maximum strength that endure the continuous operation with maximum power. All impellers are balanced to ANSI/AMCA Standard 204-05 . Yilida's internal standard is G2.5 or higher for wheel balancing.

### 3. Frame

The frames for type L, R construction are made of galvanized steel angle iron bars . The cutting and bending of the frame parts, as well as the TOX connections, are formed with the use of toolings to assure the high accuracy and the rigidity of the frames; The frames for K constructions are welded by angle steel and flat steel, and finished with polyester coating in order to ensure sufficient rigidity and strength. The bearing supports are machined to ensure proper installation and alignments of the bearings.

### 4. Bearings

The SYD series fans are using high-quality ball bearings. They are selected to minimize the noise levels. For type R and L fans, the bearings are mounted on bearing bracket as well as shock-proof washer. The bearings are pre-lubricated, sealed, self-centering and maintenance-free. For type K fans are supplied with eccentric shaft bearings. The bearing design life ( $L_{10}$ ) is above 100000 hours.

### 5. Shaft

The shafts are made of 40 Cr carbon steel bars. The shafts are rough machined and then stress relieved with heat treatment before final machining. The shaft diameters are machined to very accurate tolerance levels and they are fully checked to ensure precision fit. Each shaft is made turned, ground and polished. They are coated after assembly to provide corrosion resistance. Shaft size should be designed to meet the first critical speed of at least fan maximum running speed 1.4 times.

### 6. Outlet Flange

The outlet flange is made of galvanized steel. The connections of the flange components to the scroll are made using a TOX non-welding process. This maintains a good flange appearance while also providing sufficient strength and rigidity.

## 风机性能

### 1、风机选型示意图例

型号 Type	SYD500K
风量 Volume	$q_v=15700\text{m}^3/\text{h}$
全压 Total Pressure	$P_{IF}=839\text{Pa}$
动压 Dynamic Pressure	$P_{DF}=109\text{Pa}$
出口速度 Outlet Velocity	$C=13.5\text{m/s}$
风机转速 Fan Speed	$n=980\text{r/min}$
轴功率 Shaft Power	$P_{sh}=5.34\text{KW}$
A声功率级 A Sound Power Level	$L_{WA}=86\text{dB(A)}$
全压效率 Total Efficiency	$\eta_{IF}=68.5\%$

## Performance Chart

### 1. Fan Performance Curve

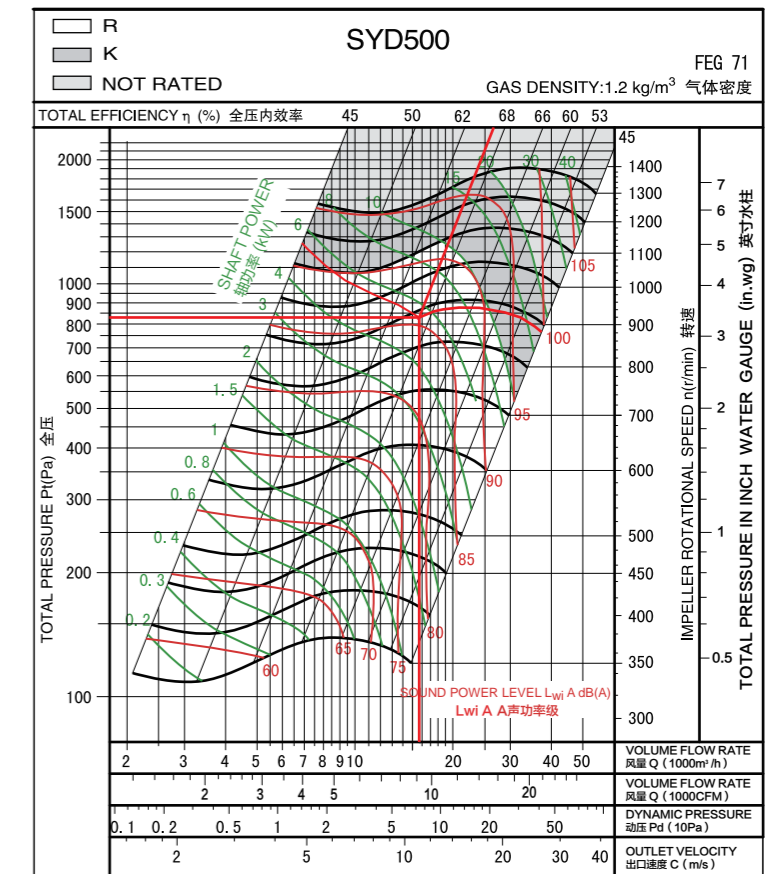



## 2、电机的选配

性能曲线图上的功率 Psh 是指风机的轴功率。  
配套电机的功率： $P=Psh \times K \div \eta_{me}$   
风机传动效率的取值方法可参照表 1，  
电机容量安全系数的取值方法可参照表 2。

表1(Table 1)

风机传动方式	Drive type	$\eta_{me}$
电机直联传动	Motor Direct Driven	1
联轴器直联传动	Coupling Direct Driven	0.98
三角皮带传动	V-Belt Driven	0.95

## 3.双联风机的性能计算

L2 型、R2 型、K2 型双联风机性能与 L 型、R 型、K 型风机曲线上所示性能比较，在压力相同的情况下，双联风机性能如下：

风量	x 2	转速	x 1.05
轴功率	x 2.15	噪声	+ 3 dB

双联风机的性能未获得 AMCA International 授权。

## 安装与维护

### A) 皮带传动安装

- 1、拆除风机轴端的保护并检查有无缺口和毛刺；
- 2、检查风机和电机轴之间的平行度；
- 3、中心距控制在  $0.7(d1+d2) < a < 2(d1+d2)$ ，前向风机皮带速度应控制在 10~15m/s；后向风机皮带速度应控制在 25~35m/s；
- 4、将皮带轮套在轴上滑进去，不要敲击，以免损伤轴承；
- 5、用一根直尺把风机和电机上的带轮对齐并紧固；
- 6、把皮带套进皮带轮，不要撬、挤压，以免损伤皮带；
- 7、调整张紧度直至皮带看起来松紧适度，风机运行几分钟后，再调整皮带至合适的张紧度；

## 2. Motor selection

The power (Psh) on the performance chart refers to the shaft power of the fan.  
The rated power of the drive motor equals the total required shaft input multiplied by the safety factor:  $P=Psh \times K + \eta_{me}$   
The value of mechanical drive efficiency can be obtained from Table 1.  
The required safety factors is provided in Table 2.

表2(Table 2)

电机功率	Power of electric motor (Kw)	K值Value k
$\leq 0.75Kw$		1.3
$\leq 2.2Kw$		1.2
$\leq 7.5Kw$		1.15
$\geq 11Kw$		1.1

## 3.The twin fan performance calculation

Comparing the performance of the twin fan of Category L2, R2 and K2 with the comparable single fan performance of L, R and K. In the same condition of pressure, the twin fans' performance are as the following:

Volume	x 2	RPM	x 1.05
Shaft Power	x 2.15	Noise	+ 3 dB

Performance of twin ventilators are not licensed by AMCA International.

## Installation and Maintenance

### A) V-belt drive Installation

1. Remove the protective coating from the ends of the fan shaft and ensure that the shaft ends are free of nick and burrs.
2. Check fan and motor shafts for alignment.
3. The center distance must be controlled as  $0.7(d1+d2) < a < 2(d1+d2)$ , The belt speed of forward curve fan should be more than 10m/s, but less than 15m/s, ( $10 < v < 15m/s$ ). The belt speed of backward curve fan should be more 25m/s, but less than 35m/s ( $25 < v < 35m/s$ ).
4. Slide sheaves on to the shafts, Do not hammer the sheaves on to the shafts with force as this may result in bearing damage.
5. Align fan and motor sheaves with a straight-edge, and tighten the sheaves.
6. Place belts over the sheaves with care. Do not bend or squeeze the belts or it might get damaged.
7. Adjust the belt tension until the belts appear snug. Run the unit for a few minutes and allow the belts to set properly.

8、关掉风机，移动电机座以调整张紧度，当风机工作时，皮带紧的一边是两个皮带轮连成的一条直线，松的一边有轻微弧形。

图3(Fig3)

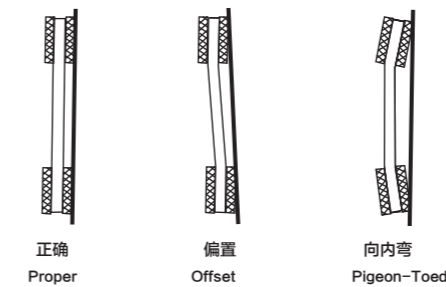

### B) 皮带松紧度

合适的皮带松紧度对使用寿命来说很重要，太紧会给皮带和轴承带来额外的负载，降低它们的使用寿命，太松会出现皮带打滑现象而产生热能并降低使用寿命。

皮带松紧度量具用来判断皮带是否松紧合适。量具本身带有一个尺表，根据皮带轮中心距和皮带横截面确定皮带张紧力的大小，如图 4 和表 3。

如没有皮带张紧度量具，应调节皮带松紧至风机启动时皮带不发生尖叫声为止，如发生短促的叫声是允许的。

拉紧皮带后、开动风机之前，重新检查皮带轮的对齐情况，如有必要则重新调整对齐。新皮带在开始使用时可能有点拉伸，则应在运行几天后重新检查皮带张紧度。

表4 (Fig4)

与中心距有关的皮带张紧度指示  
Belt tension indicator applied to mid centre distance.

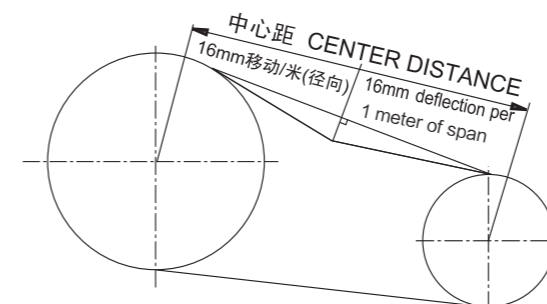

8. Switch off the fan, adjust the belt tension by moving the motor base. When in operation, the tight side of the belts should be in a straight line from sheave to sheave and there should be a slight bow on the slack side.



### B) Belt tension

A proper level of belt tension is required in order to obtain a satisfactory belt life. If the belt tension level is too high, excessive loads will be imposed on the belts and the bearing, and this will reduce the lives of both of these components. If the belt tension level is too low, the belt will slip. Belt slippage generates a large amount of heat, and this heat will drastically reduce the life of a belt.

Belt-tensioning gauges can be used to determine whether the belts are tensioned properly. A chart is normally supplied with the gauge which indicates the ranges of forces required to deflect the belts by a given amount to obtain the proper belt tension level. The required forces are based upon the center distance of the sheaves and the belt cross-section. The belts are properly tensioned when the forces required to deflect the belt are within the specified range, see Fig 4 and Table 3.

If a belt-tensioning gauge is not available, then the belt should be tightened just enough so that the belt does not squeal when the ventilator is started. A very short period of noise during the starting of a ventilator is allowable, but a squeal lasting several seconds or longer is not acceptable. After tensioning the belts and before starting the fan, check to make sure that the sheaves are properly aligned.

Realign the sheaves if necessary. Note that new belts may stretch a little during initial use, so the belt tension level should be checked after a few days of operation.

表3 (Table3)

皮带截面 Belt Section	使皮带向下移动16mm径向距离1米所需的力 Force required to deflect belt 16mm per metre of span		
	张紧力 (小皮带轮直径) Small Pulley Diameter (mm)	牛顿 Newtonian (N)	千克力 Kilogram force (Kgf)
SPZ	56-95	13-20	1.3-2.0
	100-140	20-25	2.0-2.5
SPA	80-132	25-35	2.5-3.6
	140-200	35-45	3.6-4.6
SPB	112-224	45-65	4.6-6.6
	236-315	65-85	6.6-8.7
SPC	224-335	85-115	8.7-11.7
	375-560	115-150	11.7-15.3
A	80-140	10-15	1.1-1.5
B	125-200	20-30	2.0-3.1

### C) 轴承润滑

亿利达风机不带座轴承有支架减振套橡胶圈, 轴承已预先润滑, 不必加润滑油。风机使用带座轴承, 可通过加油嘴注入润滑油。润滑油有效期取决于油脂类型、轴承的转速和工作温度。判断是否加油的最好办法是当加新油时观察清除下来的旧油脂, 如果清除下来的油脂看起来像是新的, 则可延长换油脂的间隔, 可延长换油脂的间隔; 如果清除下来的油脂比新的黑得多表明油脂已氧化, 应缩短换油脂的间隔。

### C) Bearing Lubrication

The fan bearings are filled with lubricant when they ship from the factory, so the bearings do not require any additional grease to be supplied before starting the fan. The fans that are equipped with pillow block bearing are provided with lubrication fittings, and these fittings allow for additional lubrication to be supplied to the bearings at regular intervals. The allowable period of time between lubrication of these bearings depends upon the operating speeds and temperatures of the bearing as well as on the type of lubrication. It is recommended to inspect the condition of the grease that is discharged from the bearings when new grease is added. If the discharged grease looks similar to the new grease, then a longer period of time between lubrications is possible. If the discharged grease is much darker than the new grease, this indicates that the grease is being oxidized and more frequent lubrications of the bearings are required.

### 说明

- 1) 订货时须注明风机型号、转速、风量、风压、出风口方向和旋转方向。若需配套皮带、皮带轮、电机、安装底座等配件及其它特殊要求可在订货时提出。
- 2) 在安装前应对风机各部件进行检查, 对叶轮、主轴和轴承等主要机件应重点细致检查, 如有损伤应修复后再安装使用。
- 3) 检查机壳和其它壳体内部, 不应有掉入、遗留的工具和杂物。
- 4) 风机正式运转前, 需检查电机的转向是否符合风机转向的要求。
- 5) 风管与出风口之间应采用软连接, 接头不得拉紧。
- 6) 风机安装后用手或杠杆拨动叶轮, 检查是否过紧或碰撞现象, 确认无这些现象时方可进行试转。
- 7) 风机配用电机功率是指在特定工况下, 风机内功率加上机械损失与电机容量安全系数而言, 并非出风口全敞开时所需的功率。为防止电机超功率运行而烧毁, 严禁风机出风口或进风口不接管路或未加外界任何阻力进行空运转。
- 8) 风机在无较大腐蚀性气体、不含酸(碱)性和尘粒物质小于 150mg/m<sup>3</sup> 的气体、温度小于 85℃ 大于 -20℃ 的气体环境下使用, 风机在运输装卸过程中应小心轻放, 防止碰撞挤压。

### Instructions

- 1) When placing the order, it is necessary to state the type of fan, speed, air volume, air pressure, discharge direction, rotation direction, type of electric motor and its specifications.
- 2) Prior to installation, the fan should be carefully inspected. Special care should be taken in checking the shaft, impeller and bearings. If there is an indication of any damage, the damaged parts should be repaired or replaced before the fan is installed or commissioned.
- 3) The inside of the scroll and casing need to be checked to make sure that there are no foreign objects inside the housing, such as tools or loose parts.
- 4) The rotational directions of the motor and impeller should be checked to ensure that they are in compliance with the specification and purchase orders.
- 5) A flexible connector should be used between the fan outlet flange and its mating ductwork. The flex connector should not be over-stretched.
- 6) Following the installation, the impeller should be turned by hand or with the use of a wrench to make sure that it turns freely without colliding with other parts of the fan. Once all this is done, the fan can be commissioned normally.
- 7) The rated motor power as calculated herein might not be sufficient to drive the fan with an unrestricted discharge flow. Operating the fan with an unrestricted discharge outlet will result in flow rate that exceeds the specified fan capabilities. Such operation will quickly burn the motor and damage the fan. Great care must be taken in operating the fan to make sure that the maximum rated flows, as provided on the performance charts in this catalog, are not exceeded.
- 8) The fan is limited for use in areas where air substances are non-corrosive, non-toxic and non-erosive and where dust particles are less than 150mg/m<sup>3</sup> with a temperature between -20°C and 85°C. Special care should be taken during transportation, load and unload.

### 技术参数

Wheel diameter	叶轮直径	D = 200 mm	Fan weight	风机质量	m = 9.4 kg
Moment of inertia	转动惯量	J = 0.015 kg·m <sup>2</sup>	Speed limit	极限转速	n <sub>max</sub> = 3200 r/min

### Technical Data

### 性能曲线

经认证的性能是B类安装: 自由入口, 管道出口。功率额定值(kW)不包括传输损失。各项性能额定值不包括附属物(附件)的影响。所示A加权声音性能额定值已按AMCA International标准301计算。所示值为安装类型B: 自由入口, 管道出口的声功率级(入口L<sub>wA</sub>)。

### Performance Curve

Performance certified is for installation type B: free inlet, ducted outlet. Power rating (kW) does not include transmission losses. Performance ratings do not include the effects of appurtenances (accessories). The A-weighted sound ratings shown have been calculated per AMCA International Standard 301. Values shown are for inlet L<sub>wA</sub> sound power levels for installation type B: free inlet, ducted outlet.

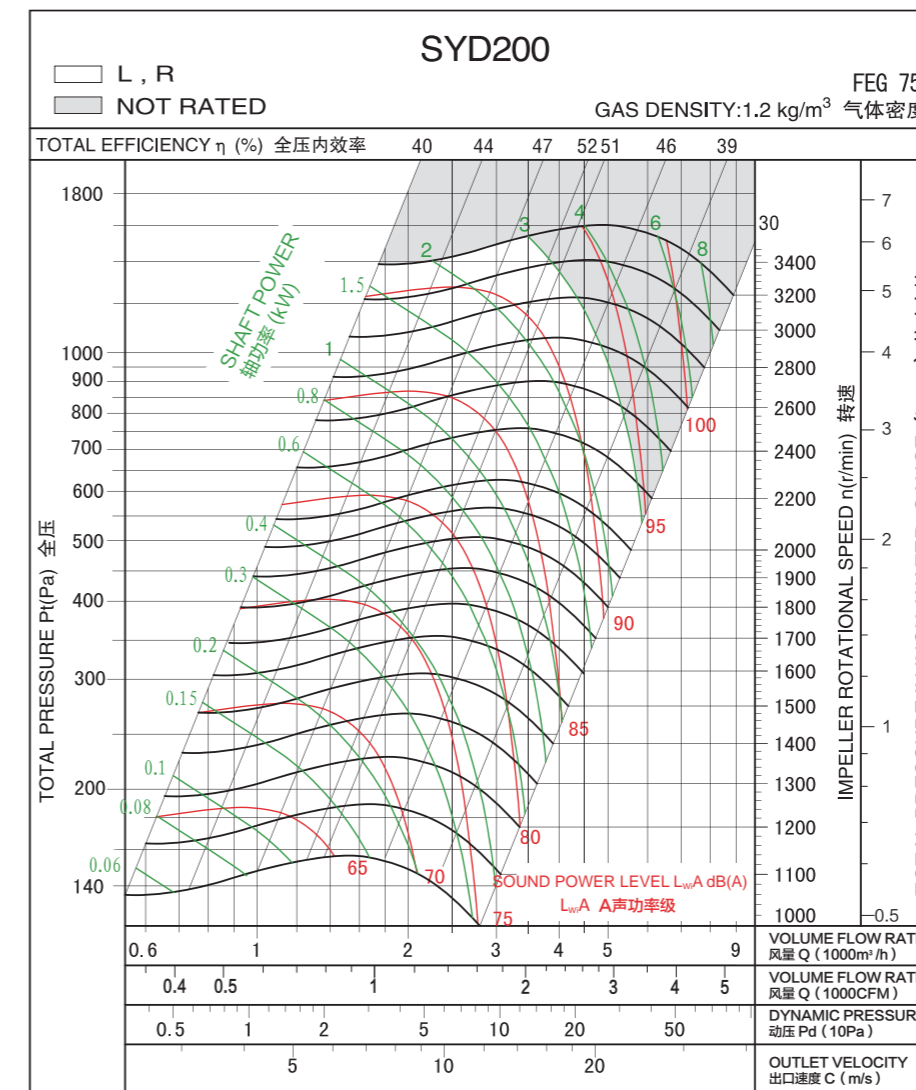

Measured in installation B according to AMCA Standard 210:

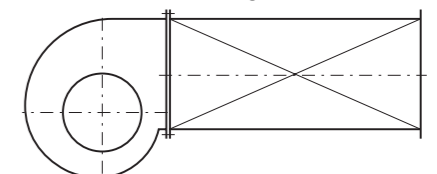

## 技术参数

## Technical Data

Wheel diameter 叶轮直径	D = 225 mm	Fan weight 风机质量	m = 10.8 kg
Moment of inertia 转动惯量	J = 0.021 kg·m <sup>2</sup>	Speed limit 极限转速	n <sub>max</sub> = 2800 r/min

## 技术参数

## Technical Data

Wheel diameter 叶轮直径	D = 250 mm	Fan weight 风机质量	m = 13 kg
Moment of inertia 转动惯量	J = 0.038 kg·m <sup>2</sup>	Speed limit 极限转速	n <sub>max</sub> = 2400 r/min

## 性能曲线

## Performance Curve

经认证的性能是B类安装：自由入口，管道出口。功率额定值(kW)不包括传输损失。各项性能额定值不包括附属物(附件)的影响。所示A加权声音性能额定值已按AMCA International标准301计算。所示值为安装类型B：自由入口，管道出口的声功率级（入口L<sub>WA</sub>）。

Performance certified is for installation type B: free inlet, ducted outlet. Power rating (kW) does not include transmission losses. Performance ratings do not include the effects of appurtenances (accessories). The A-weighted sound ratings shown have been calculated per AMCA International Standard 301. Values shown are for inlet L<sub>WA</sub> sound power levels for installation type B: free inlet, ducted outlet.

## 性能曲线

## Performance Curve

经认证的性能是B类安装：自由入口，管道出口。功率额定值(kW)不包括传输损失。各项性能额定值不包括附属物(附件)的影响。所示A加权声音性能额定值已按AMCA International标准301计算。所示值为安装类型B：自由入口，管道出口的声功率级（入口L<sub>WA</sub>）。

Performance certified is for installation type B: free inlet, ducted outlet. Power rating (kW) does not include transmission losses. Performance ratings do not include the effects of appurtenances (accessories). The A-weighted sound ratings shown have been calculated per AMCA International Standard 301. Values shown are for inlet L<sub>WA</sub> sound power levels for installation type B: free inlet, ducted outlet.

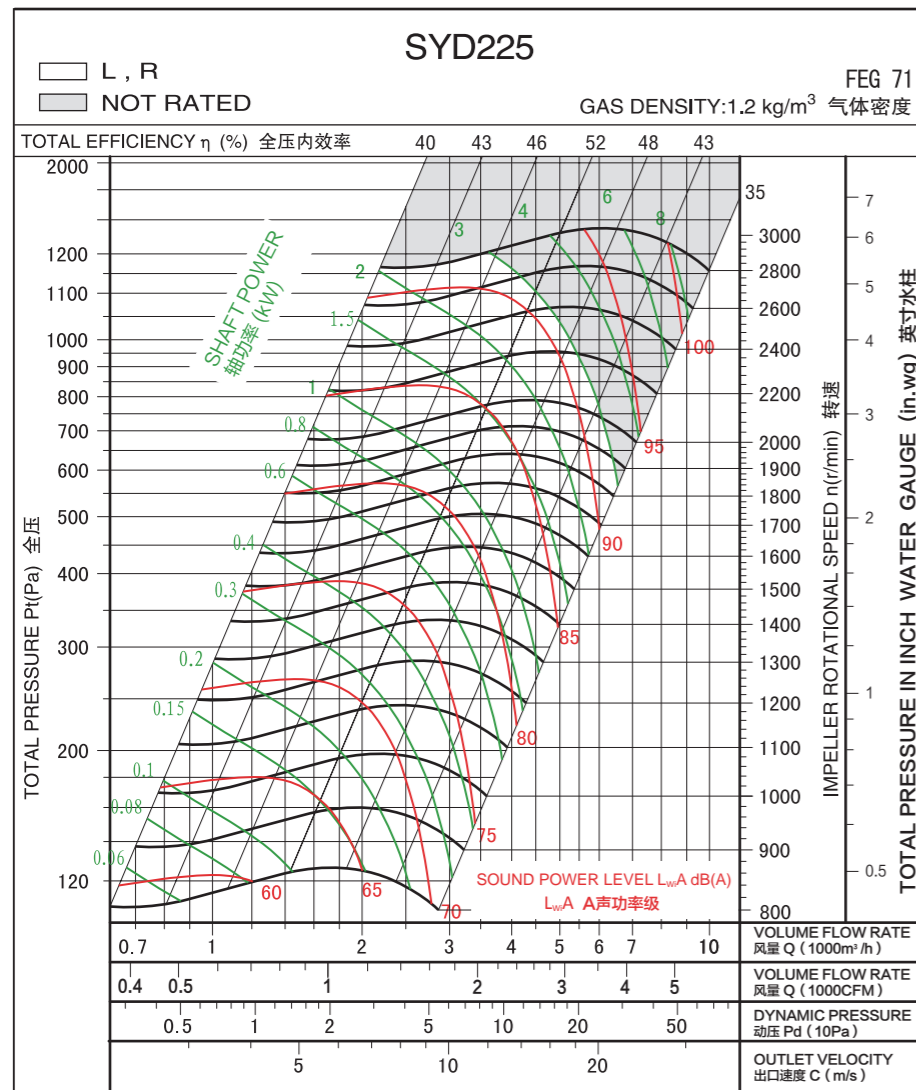

Measured in installation B according to AMCA Standard 210:

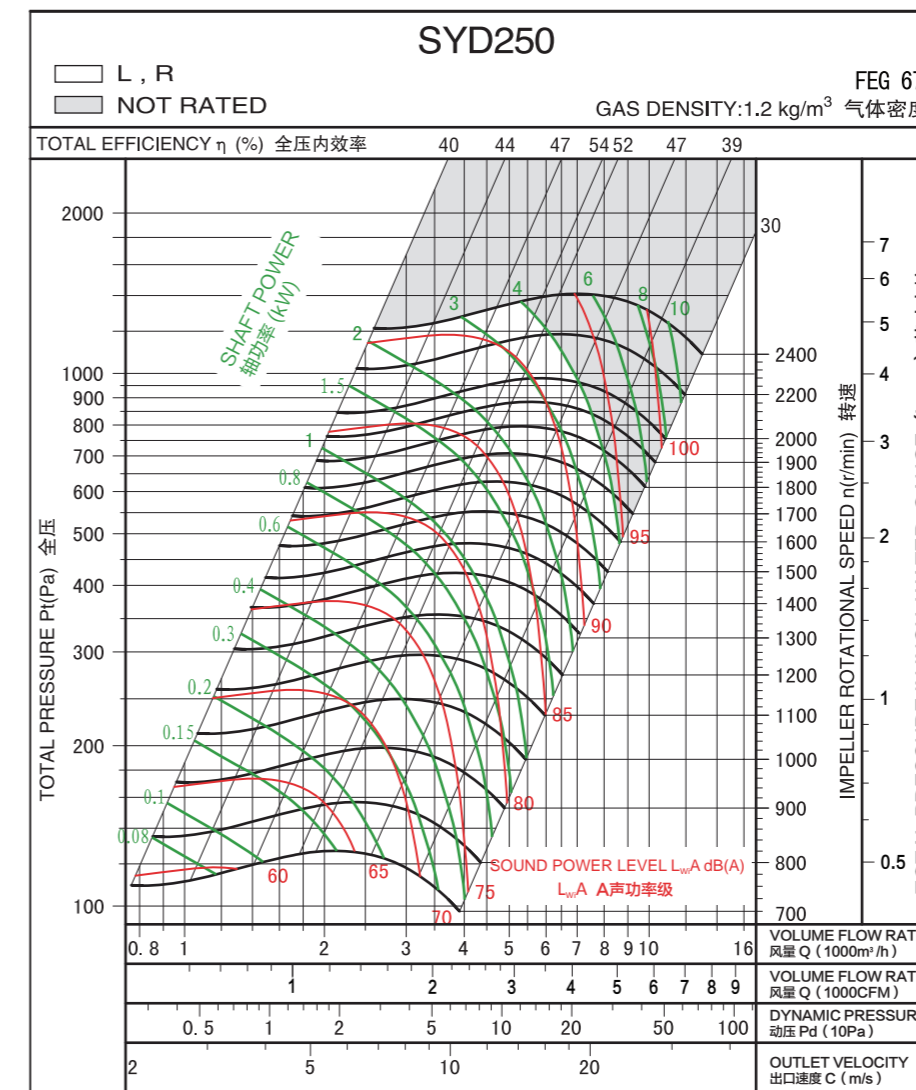
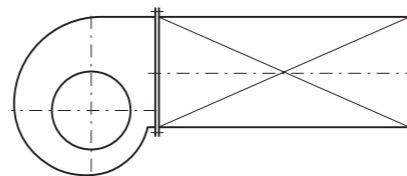

Measured in installation B according to AMCA Standard 210:

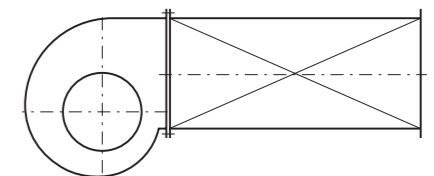



## 技术参数

## Technical Data

Wheel diameter 叶轮直径	D = 280 mm	Fan weight 风机质量	m = 29 kg
Moment of inertia 转动惯量	J = 0.06 kg·m <sup>2</sup>	Speed limit 极限转速	n <sub>max</sub> = 2500 r/min

## 技术参数

## Technical Data

Wheel diameter 叶轮直径	D = 315 mm	Fan weight 风机质量	m = 35 kg
Moment of inertia 转动惯量	J = 0.1 kg·m <sup>2</sup>	Speed limit 极限转速	n <sub>max</sub> = 2200 r/min

## 性能曲线

## Performance Curve

经认证的性能是B类安装：自由入口，管道出口。功率额定值(kW)不包括传输损失。各项性能额定值不包括附属物(附件)的影响。所示A加权声音性能额定值已按AMCA International标准301计算。所示值为安装类型B：自由入口，管道出口的声功率级（入口L<sub>WA</sub>）。

Performance certified is for installation type B: free inlet, ducted outlet. Power rating (kW) does not include transmission losses. Performance ratings do not include the effects of appurtenances (accessories). The A-weighted sound ratings shown have been calculated per AMCA International Standard 301. Values shown are for inlet L<sub>WA</sub> sound power levels for installation type B: free inlet, ducted outlet.

## 性能曲线

## Performance Curve

经认证的性能是B类安装：自由入口，管道出口。功率额定值(kW)不包括传输损失。各项性能额定值不包括附属物(附件)的影响。所示A加权声音性能额定值已按AMCA International标准301计算。所示值为安装类型B：自由入口，管道出口的声功率级（入口L<sub>WA</sub>）。

Performance certified is for installation type B: free inlet, ducted outlet. Power rating (kW) does not include transmission losses. Performance ratings do not include the effects of appurtenances (accessories). The A-weighted sound ratings shown have been calculated per AMCA International Standard 301. Values shown are for inlet L<sub>WA</sub> sound power levels for installation type B: free inlet, ducted outlet.

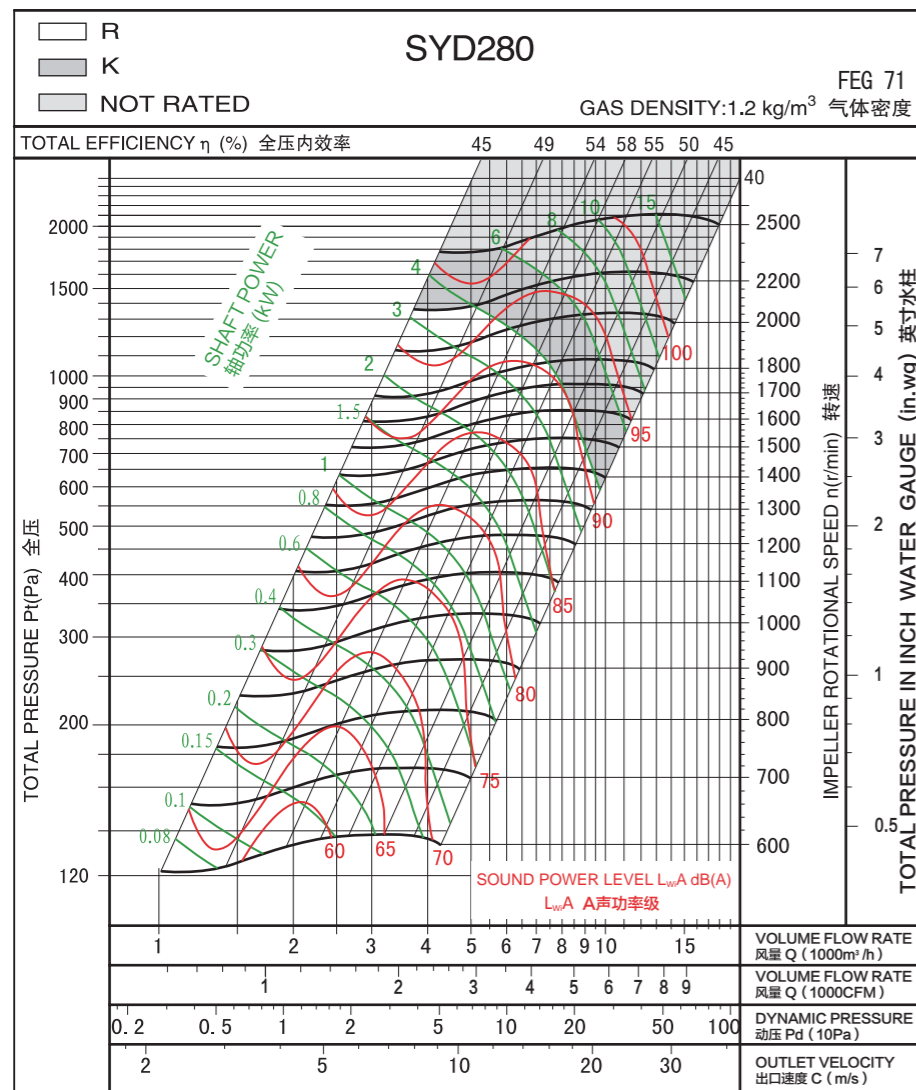

Measured in installation B according to AMCA Standard 210:

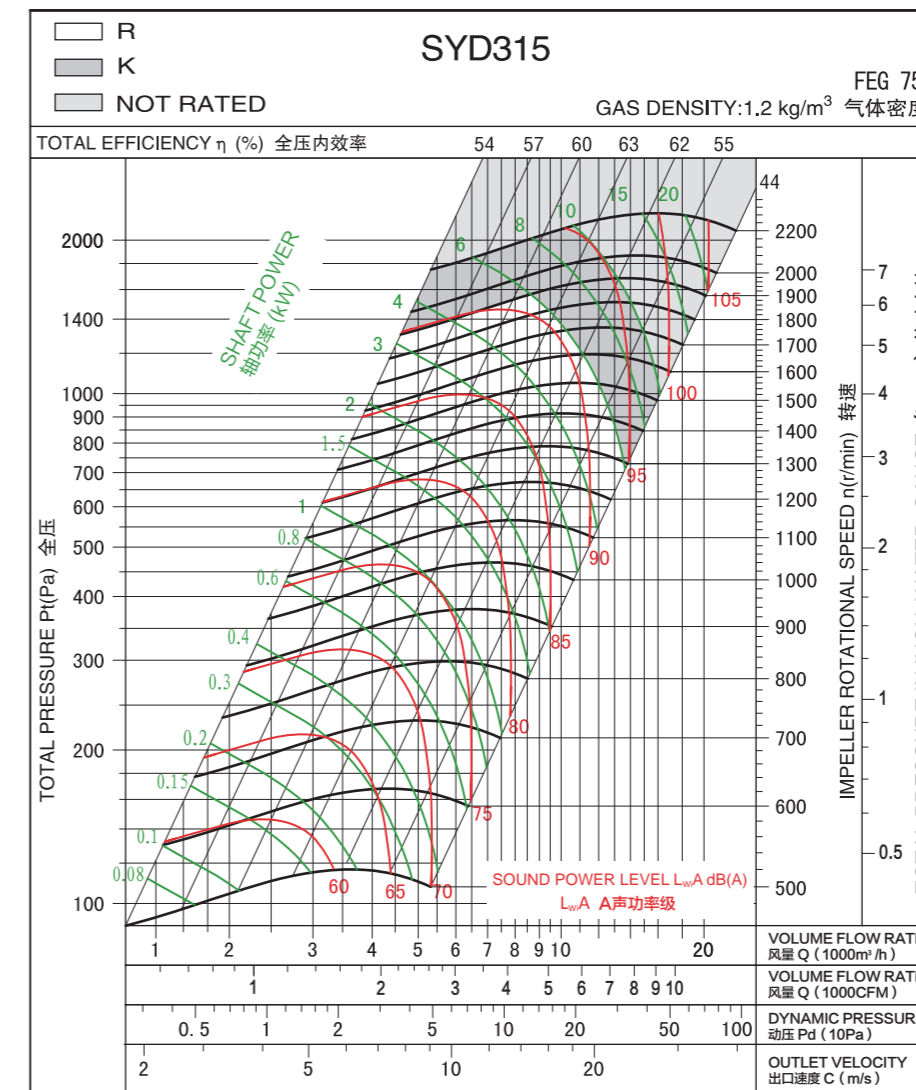
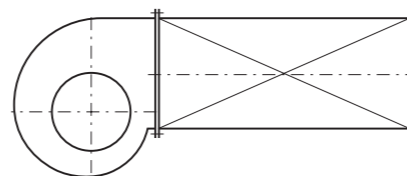

Measured in installation B according to AMCA Standard 210:

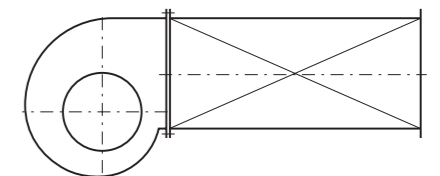

## 技术参数

## Technical Data

Wheel diameter 叶轮直径	D = 355 mm	Fan weight 风机质量	m = 42 kg
Moment of inertia 转动惯量	J = 0.15 kg·m <sup>2</sup>	Speed limit 极限转速	n <sub>max</sub> = 2000 r/min

## 技术参数

## Technical Data

Wheel diameter 叶轮直径	D = 400 mm	Fan weight 风机质量	m = 57 kg
Moment of inertia 转动惯量	J = 0.31 kg·m <sup>2</sup>	Speed limit 极限转速	n <sub>max</sub> = 1800 r/min

## 性能曲线

## Performance Curve

经认证的性能是B类安装：自由入口，管道出口。功率额定值(kW)不包括传输损失。各项性能额定值不包括附属物(附件)的影响。所示A加权声音性能额定值已按AMCA International标准301计算。所示值为安装类型B：自由入口，管道出口的声功率级（入口L<sub>WA</sub>）。

Performance certified is for installation type B: free inlet, ducted outlet. Power rating (kW) does not include transmission losses. Performance ratings do not include the effects of appurtenances (accessories). The A-weighted sound ratings shown have been calculated per AMCA International Standard 301. Values shown are for inlet L<sub>WA</sub> sound power levels for installation type B: free inlet, ducted outlet.

## 性能曲线

## Performance Curve

经认证的性能是B类安装：自由入口，管道出口。功率额定值(kW)不包括传输损失。各项性能额定值不包括附属物(附件)的影响。所示A加权声音性能额定值已按AMCA International标准301计算。所示值为安装类型B：自由入口，管道出口的声功率级（入口L<sub>WA</sub>）。

Performance certified is for installation type B: free inlet, ducted outlet. Power rating (kW) does not include transmission losses. Performance ratings do not include the effects of appurtenances (accessories). The A-weighted sound ratings shown have been calculated per AMCA International Standard 301. Values shown are for inlet L<sub>WA</sub> sound power levels for installation type B: free inlet, ducted outlet.

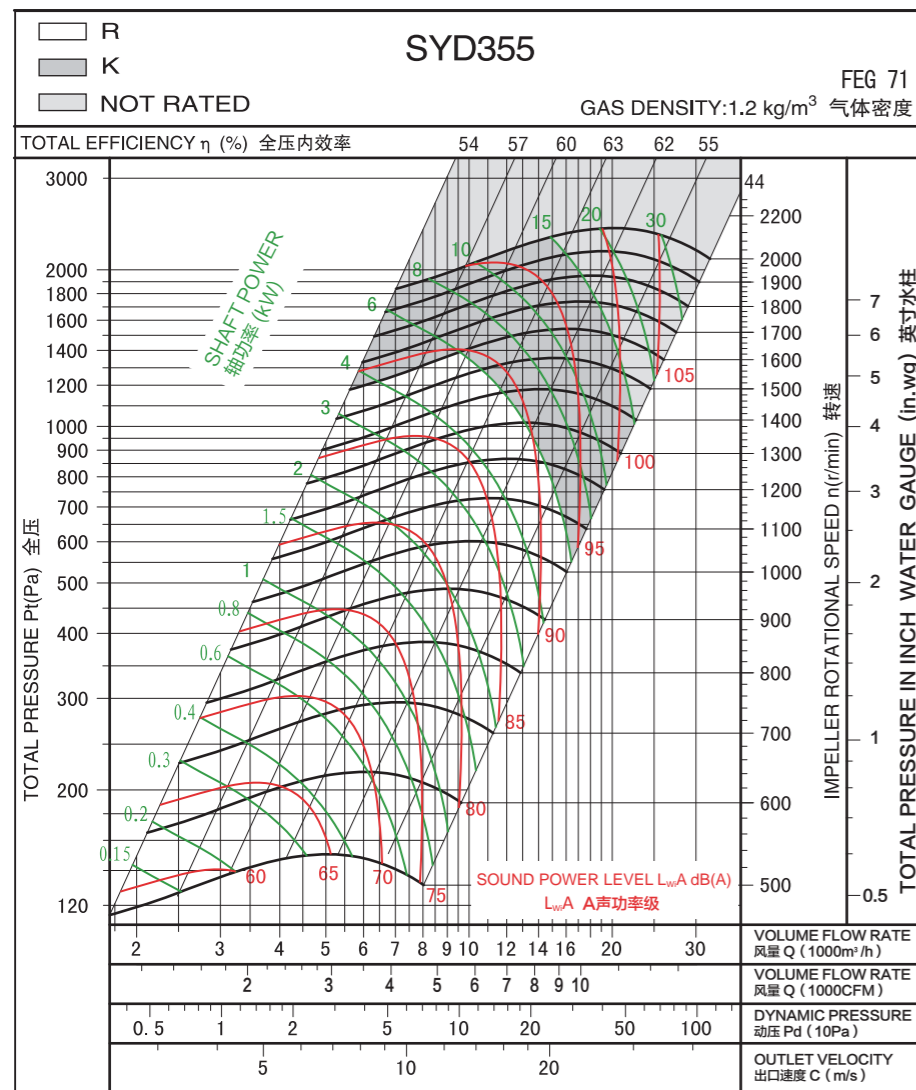

Measured in installation B according to AMCA Standard 210:

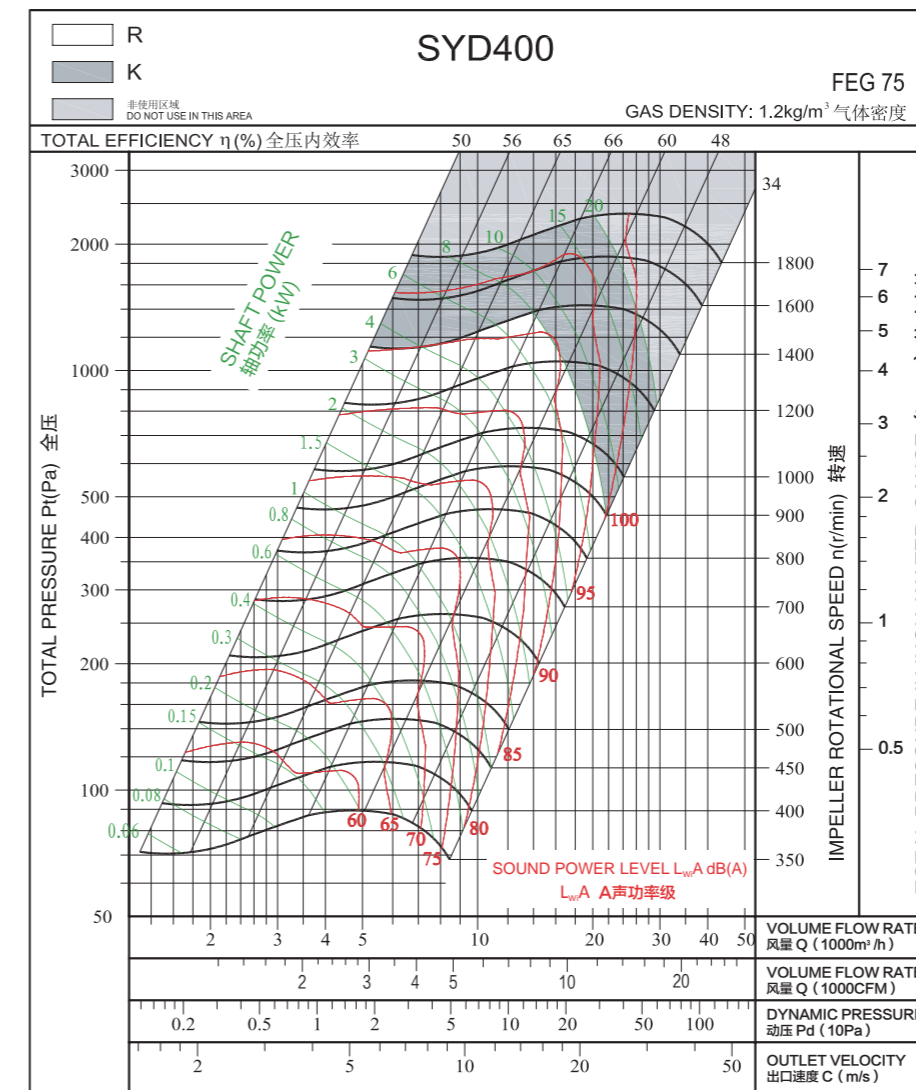
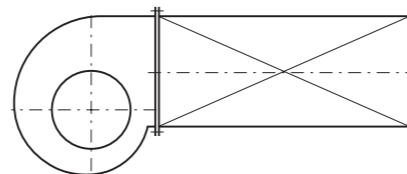

Measured in installation B according to AMCA Standard 210:

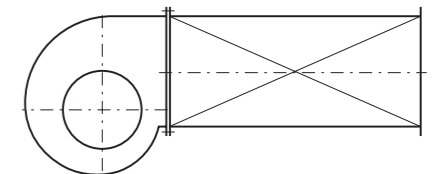

## 技术参数

## Technical Data

Wheel diameter 叶轮直径	D = 450 mm	Fan weight 风机质量	m = 72 kg
Moment of inertia 转动惯量	J = 0.48 kg·m <sup>2</sup>	Speed limit 极限转速	n <sub>max</sub> = 1600 r/min

## 技术参数

## Technical Data

Wheel diameter 叶轮直径	D = 500 mm	Fan weight 风机质量	m = 92 kg
Moment of inertia 转动惯量	J = 0.9 kg·m <sup>2</sup>	Speed limit 极限转速	n <sub>max</sub> = 1300 r/min

## 性能曲线

## Performance Curve

经认证的性能是B类安装：自由入口，管道出口。功率额定值(kW)不包括传输损失。各项性能额定值不包括附属物(附件)的影响。所示A加权声音性能额定值已按AMCA International标准301计算。所示值为安装类型B：自由入口，管道出口的声功率级（入口L<sub>WA</sub>）。

Performance certified is for installation type B: free inlet, ducted outlet. Power rating (kW) does not include transmission losses. Performance ratings do not include the effects of appurtenances (accessories). The A-weighted sound ratings shown have been calculated per AMCA International Standard 301. Values shown are for inlet L<sub>WA</sub> sound power levels for installation type B: free inlet, ducted outlet.

## 性能曲线

## Performance Curve

经认证的性能是B类安装：自由入口，管道出口。功率额定值(kW)不包括传输损失。各项性能额定值不包括附属物(附件)的影响。所示A加权声音性能额定值已按AMCA International标准301计算。所示值为安装类型B：自由入口，管道出口的声功率级（入口L<sub>WA</sub>）。

Performance certified is for installation type B: free inlet, ducted outlet. Power rating (kW) does not include transmission losses. Performance ratings do not include the effects of appurtenances (accessories). The A-weighted sound ratings shown have been calculated per AMCA International Standard 301. Values shown are for inlet L<sub>WA</sub> sound power levels for installation type B: free inlet, ducted outlet.

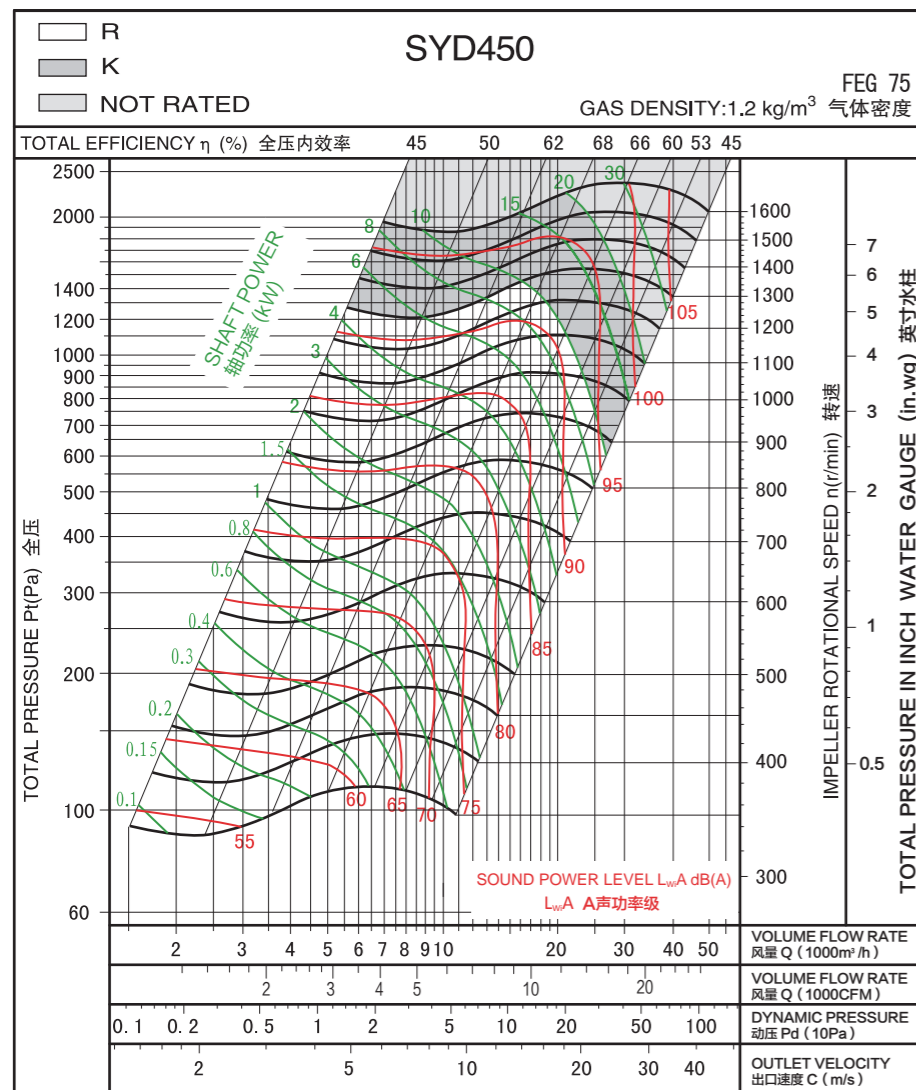

Measured in installation B according to AMCA Standard 210:

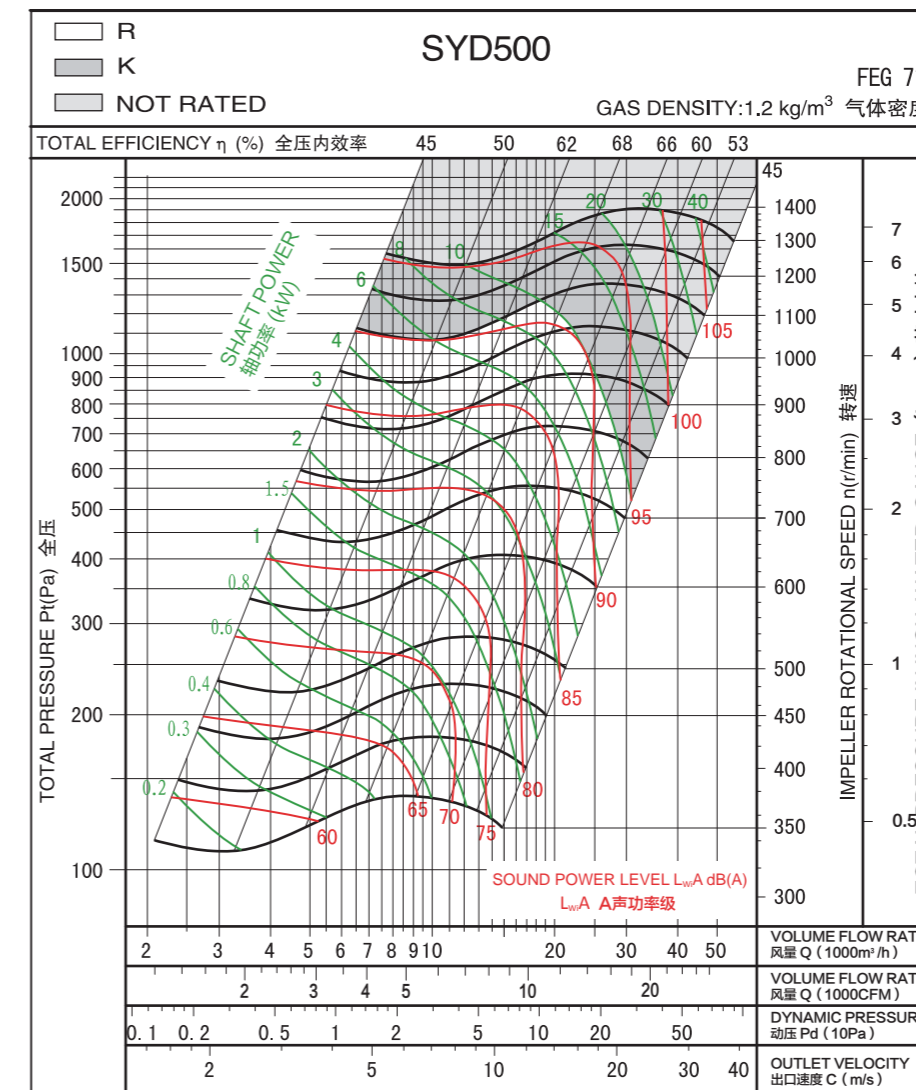
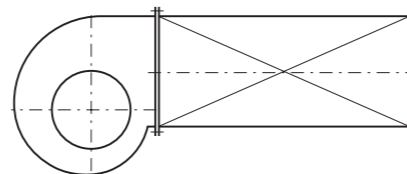

Measured in installation B according to AMCA Standard 210:

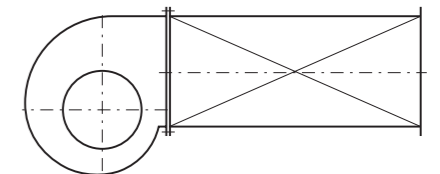



## 技术参数

## Technical Data

Wheel diameter 叶轮直径	D = 560 mm	Fan weight 风机质量	m = 160 kg
Moment of inertia 转动惯量	J = 1.66 kg·m <sup>2</sup>	Speed limit 极限转速	n <sub>max</sub> = 1200 r/min

## 技术参数

## Technical Data

Wheel diameter 叶轮直径	D = 630 mm	Fan weight 风机质量	m = 185 kg
Moment of inertia 转动惯量	J = 2.15 kg·m <sup>2</sup>	Speed limit 极限转速	n <sub>max</sub> = 1000 r/min

## 性能曲线

## Performance Curve

经认证的性能是B类安装：自由入口，管道出口。功率额定值(kW)不包括传输损失。各项性能额定值不包括附属物(附件)的影响。所示A加权声音性能额定值已按AMCA International标准301计算。所示值为安装类型B：自由入口，管道出口的声功率级（入口L<sub>WA</sub>）。

Performance certified is for installation type B: free inlet, ducted outlet. Power rating (kW) does not include transmission losses. Performance ratings do not include the effects of appurtenances (accessories). The A-weighted sound ratings shown have been calculated per AMCA International Standard 301. Values shown are for inlet L<sub>WA</sub> sound power levels for installation type B: free inlet, ducted outlet.

## 性能曲线

## Performance Curve

经认证的性能是B类安装：自由入口，管道出口。功率额定值(kW)不包括传输损失。各项性能额定值不包括附属物(附件)的影响。所示A加权声音性能额定值已按AMCA International标准301计算。所示值为安装类型B：自由入口，管道出口的声功率级（入口L<sub>WA</sub>）。

Performance certified is for installation type B: free inlet, ducted outlet. Power rating (kW) does not include transmission losses. Performance ratings do not include the effects of appurtenances (accessories). The A-weighted sound ratings shown have been calculated per AMCA International Standard 301. Values shown are for inlet L<sub>WA</sub> sound power levels for installation type B: free inlet, ducted outlet.

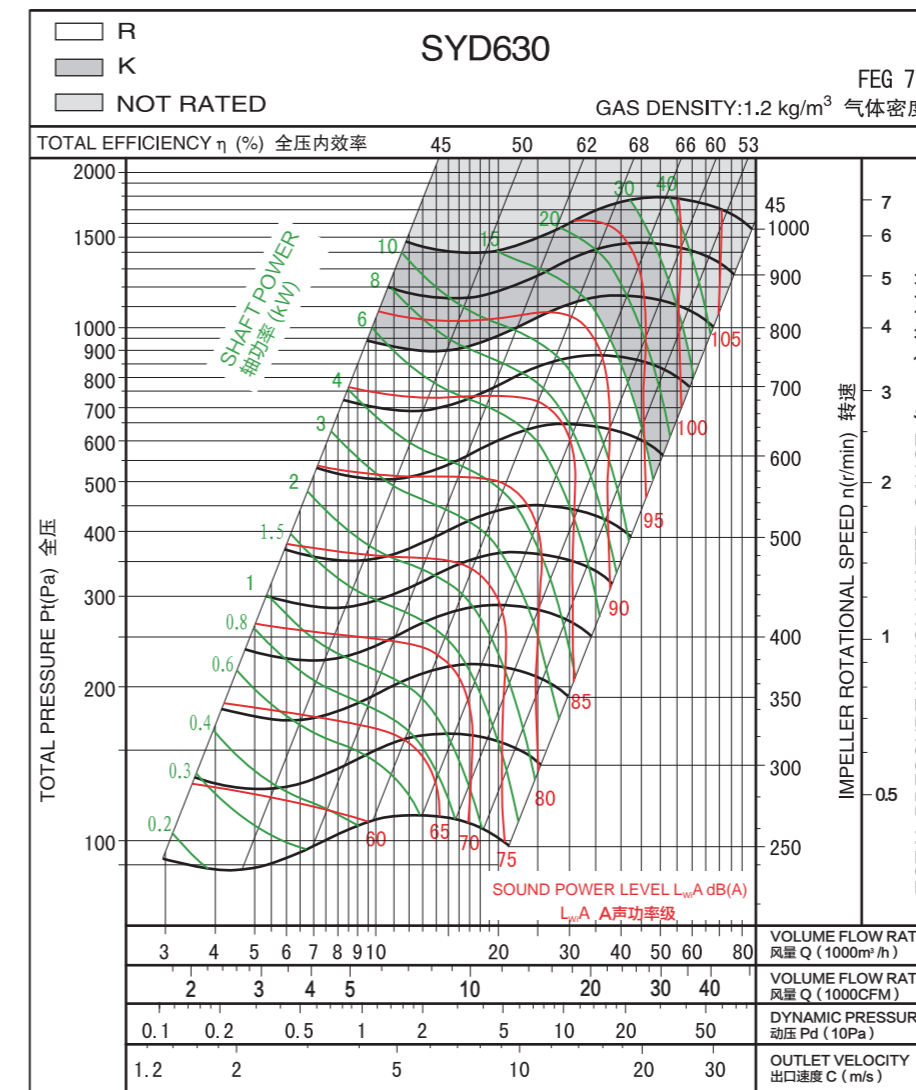
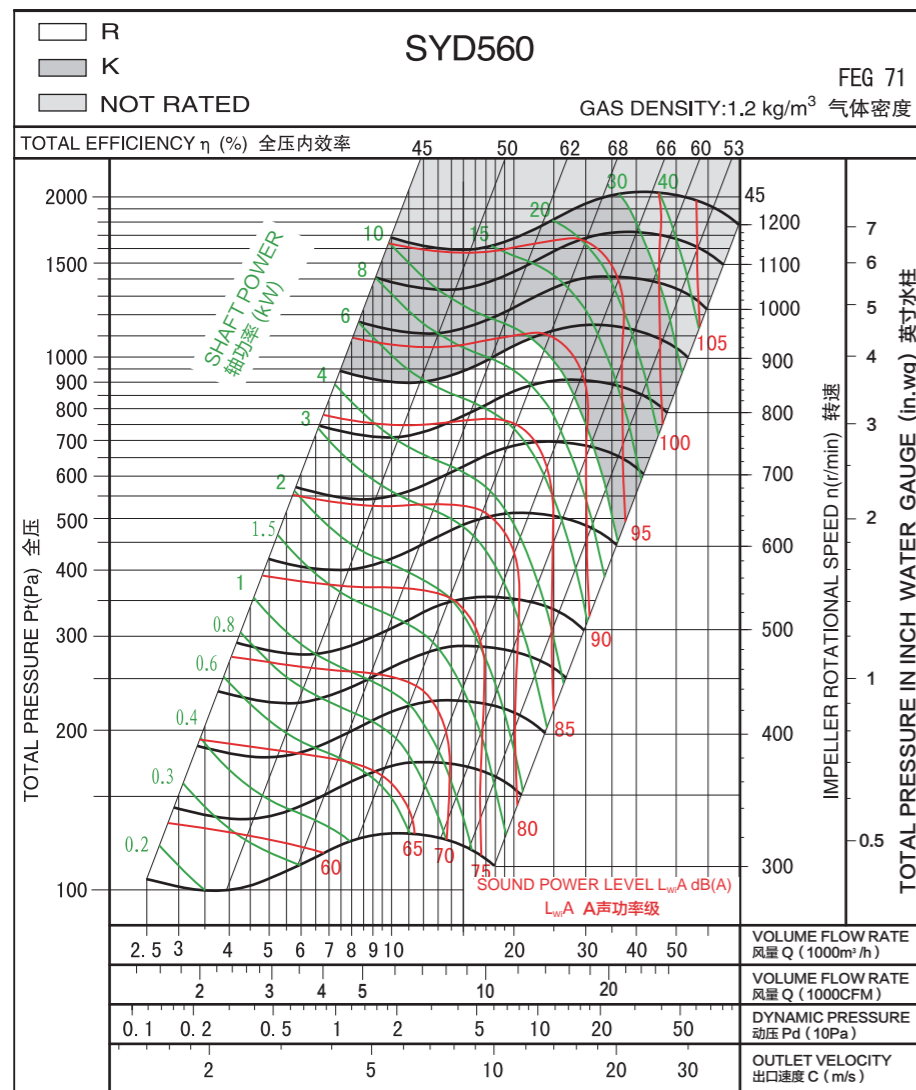

## 技术参数

## Technical Data

Wheel diameter 叶轮直径	D = 710 mm	Fan weight 风机质量	m = 240 kg
Moment of inertia 转动惯量	J = 4.02 kg·m <sup>2</sup>	Speed limit 极限转速	n <sub>max</sub> = 900 r/min

## 技术参数

## Technical Data

Wheel diameter 叶轮直径	D = 800 mm	Fan weight 风机质量	m = 290 kg
Moment of inertia 转动惯量	J = 8.31 kg·m <sup>2</sup>	Speed limit 极限转速	n <sub>max</sub> = 800 r/min

## 性能曲线

## Performance Curve

经认证的性能是B类安装：自由入口，管道出口。功率额定值(kW)不包括传输损失。各项性能额定值不包括附属物(附件)的影响。所示A加权声音性能额定值已按AMCA International标准301计算。所示值为安装类型B：自由入口，管道出口的声功率级（入口L<sub>WA</sub>）。

Performance certified is for installation type B: free inlet, ducted outlet. Power rating (kW) does not include transmission losses. Performance ratings do not include the effects of appurtenances (accessories). The A-weighted sound ratings shown have been calculated per AMCA International Standard 301. Values shown are for inlet L<sub>WA</sub> sound power levels for installation type B: free inlet, ducted outlet.

## 性能曲线

## Performance Curve

经认证的性能是B类安装：自由入口，管道出口。功率额定值(kW)不包括传输损失。各项性能额定值不包括附属物(附件)的影响。所示A加权声音性能额定值已按AMCA International标准301计算。所示值为安装类型B：自由入口，管道出口的声功率级（入口L<sub>WA</sub>）。

Performance certified is for installation type B: free inlet, ducted outlet. Power rating (kW) does not include transmission losses. Performance ratings do not include the effects of appurtenances (accessories). The A-weighted sound ratings shown have been calculated per AMCA International Standard 301. Values shown are for inlet L<sub>WA</sub> sound power levels for installation type B: free inlet, ducted outlet.

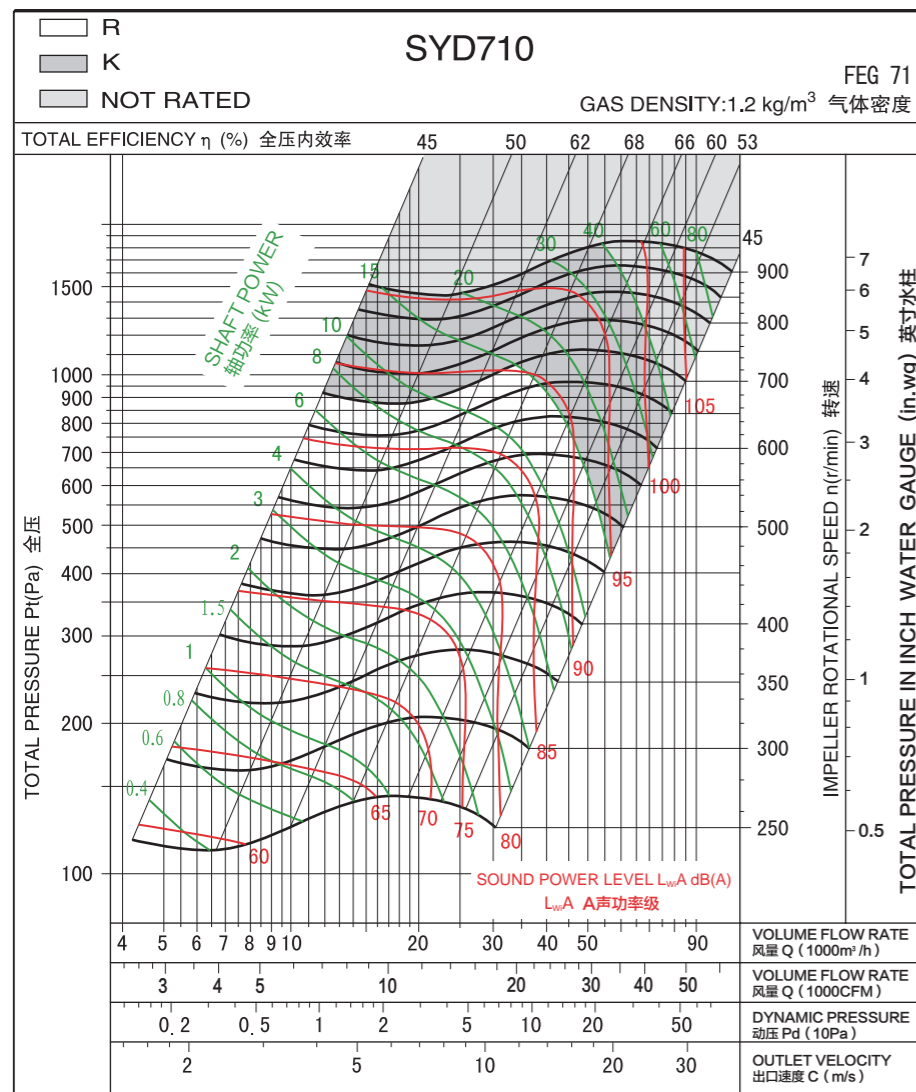

Measured in installation B according to AMCA Standard 210:

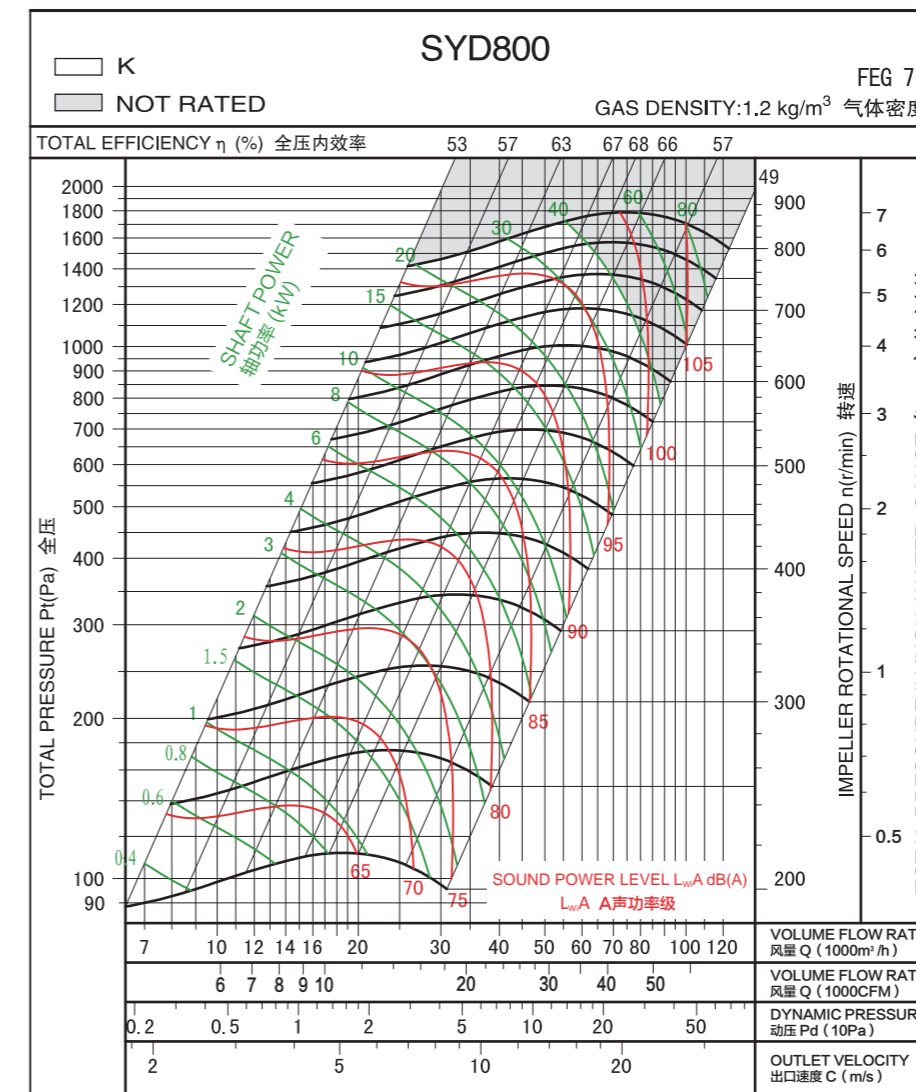
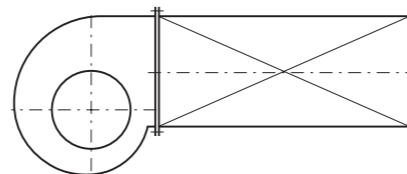

Measured in installation B according to AMCA Standard 210:

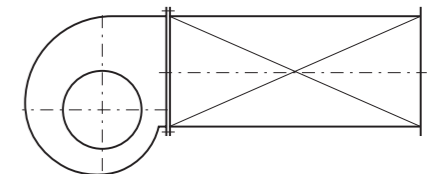

## 技术参数

## Technical Data

Wheel diameter 叶轮直径	D = 900 mm	Fan weight 风机质量	m = 365 kg
Moment of inertia 转动惯量	J = 12.7 kg·m <sup>2</sup>	Speed limit 极限转速	n <sub>max</sub> = 700 r/min

## 技术参数

## Technical Data

Wheel diameter 叶轮直径	D = 1000 mm	Fan weight 风机质量	m = 480 kg
Moment of inertia 转动惯量	J = 18.9 kg·m <sup>2</sup>	Speed limit 极限转速	n <sub>max</sub> = 600 r/min

## 性能曲线

## Performance Curve

经认证的性能是B类安装：自由入口，管道出口。功率额定值(kW)不包括传输损失。各项性能额定值不包括附属物(附件)的影响。所示A加权声音性能额定值已按AMCA International标准301计算。所示值为安装类型B：自由入口，管道出口的声功率级（入口L<sub>WA</sub>）。

Performance certified is for installation type B: free inlet, ducted outlet. Power rating (kW) does not include transmission losses. Performance ratings do not include the effects of appurtenances (accessories). The A-weighted sound ratings shown have been calculated per AMCA International Standard 301. Values shown are for inlet L<sub>WA</sub> sound power levels for installation type B: free inlet, ducted outlet.

## 性能曲线

## Performance Curve

经认证的性能是B类安装：自由入口，管道出口。功率额定值(kW)不包括传输损失。各项性能额定值不包括附属物(附件)的影响。所示A加权声音性能额定值已按AMCA International标准301计算。所示值为安装类型B：自由入口，管道出口的声功率级（入口L<sub>WA</sub>）。

Performance certified is for installation type B: free inlet, ducted outlet. Power rating (kW) does not include transmission losses. Performance ratings do not include the effects of appurtenances (accessories). The A-weighted sound ratings shown have been calculated per AMCA International Standard 301. Values shown are for inlet L<sub>WA</sub> sound power levels for installation type B: free inlet, ducted outlet.

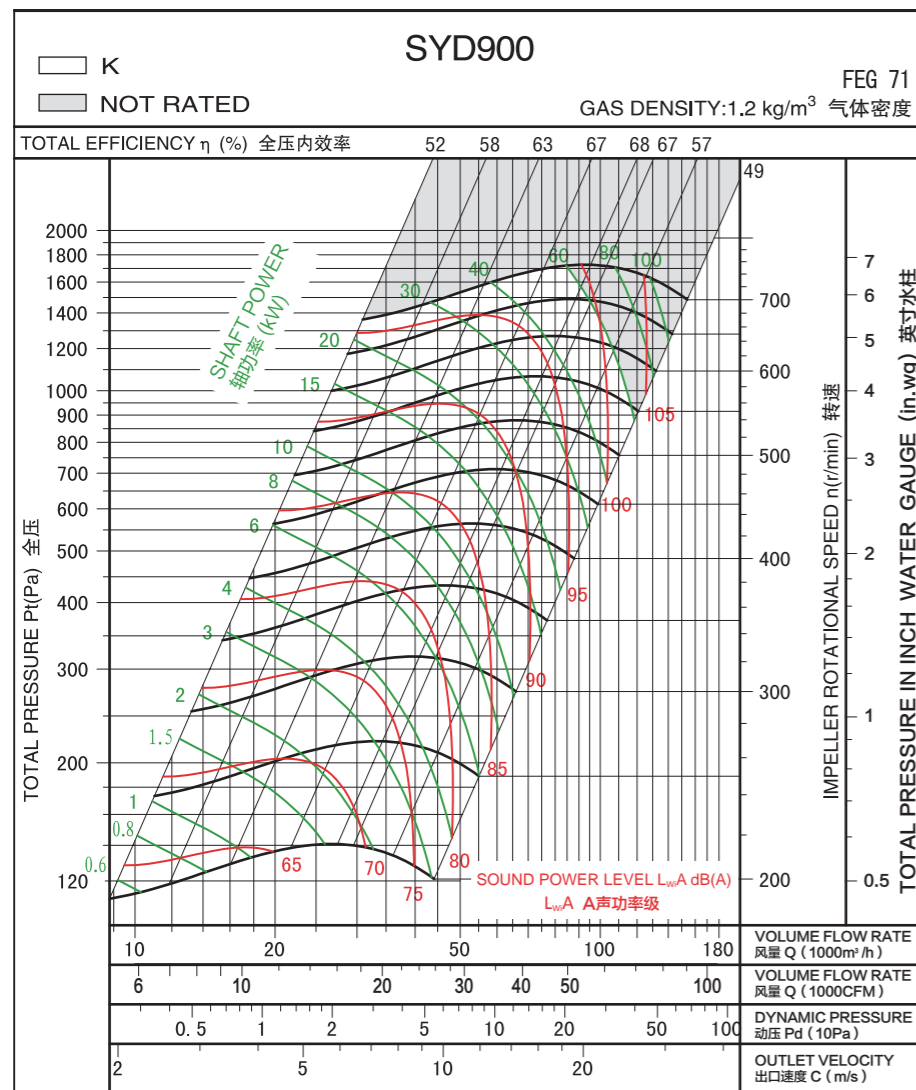

Measured in installation B according to AMCA Standard 210:

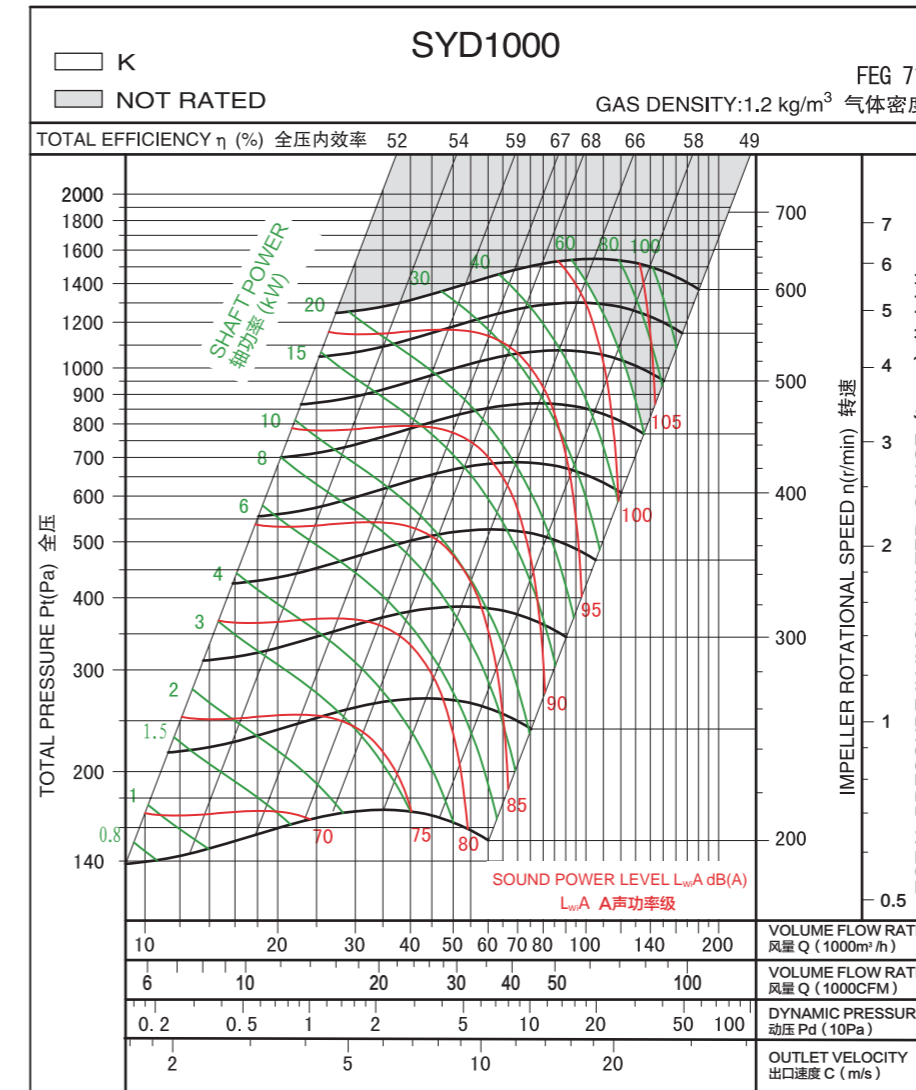
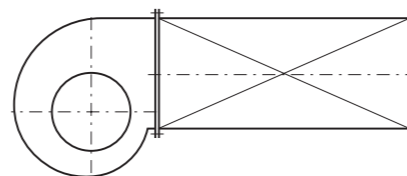

Measured in installation B according to AMCA Standard 210:

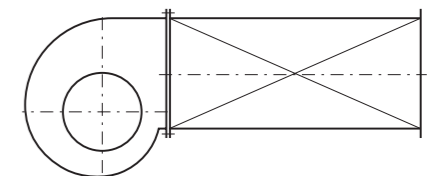



出口法兰

Outlet Flange

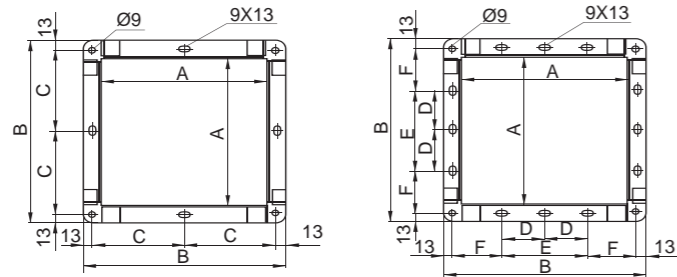

单位: mm

尺寸	型号	200	225	250	280	315	355	400	450	500	560	630	710	800	900	1000
A		256	288	322	361	404	453	507	569	638	715	801	898	1007	1130	1267
B		296	328	362	417	460	509	563	625	694	771	857	954	1063	1186	1323
C		138	154	171	195.5	217	241.5	\	\	\	\	\	\	\	\	\
D		\	\	\	\	\	\	\	\	\	\	\	200	250	300	350
E		\	\	\	\	\	\	200	200	250	250	300	400	500	600	700
F		\	\	\	\	\	\	168.5	199.5	209	247.5	265.5	264	268.5	280	298.5

SYD-L

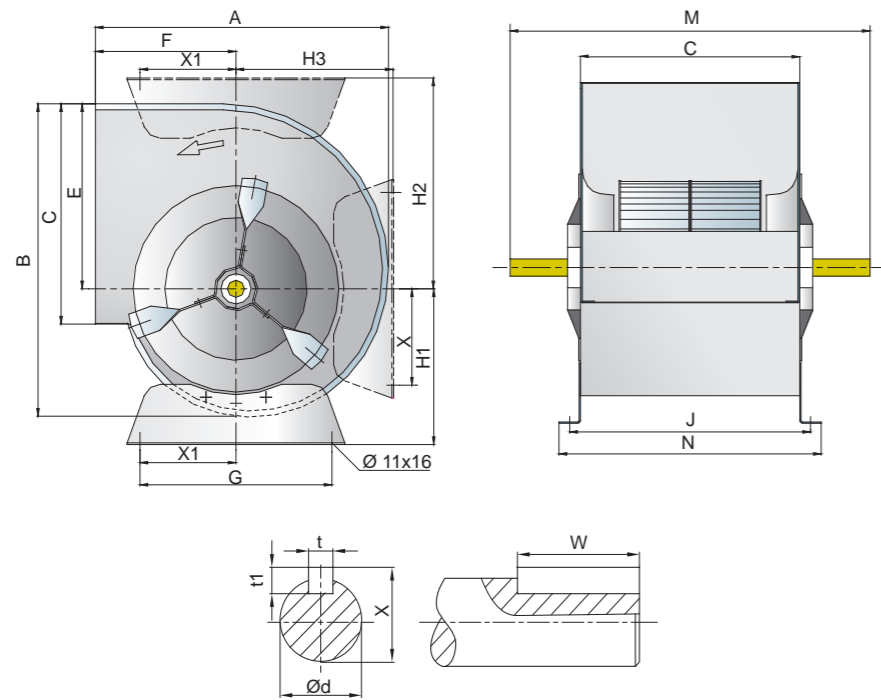

单位: mm

尺寸	型号	A	B	C	E	F	G	J	M	N	X1	H1	H2	H3	t	t1	X	W	Φd	LxV
200		342	364	256	215	164	224	281	420	306	112	181	245	184	6	6	22.5	40	20	11x16
225		380	407.8	288	243	180	224	313	460	338	112	197	274	204	6	6	22.5	50	20	11x16
250		417	454	322	270	195	224	347	490	372	112	210	299	227	6	6	22.5	50	20	11x16

SYD-R

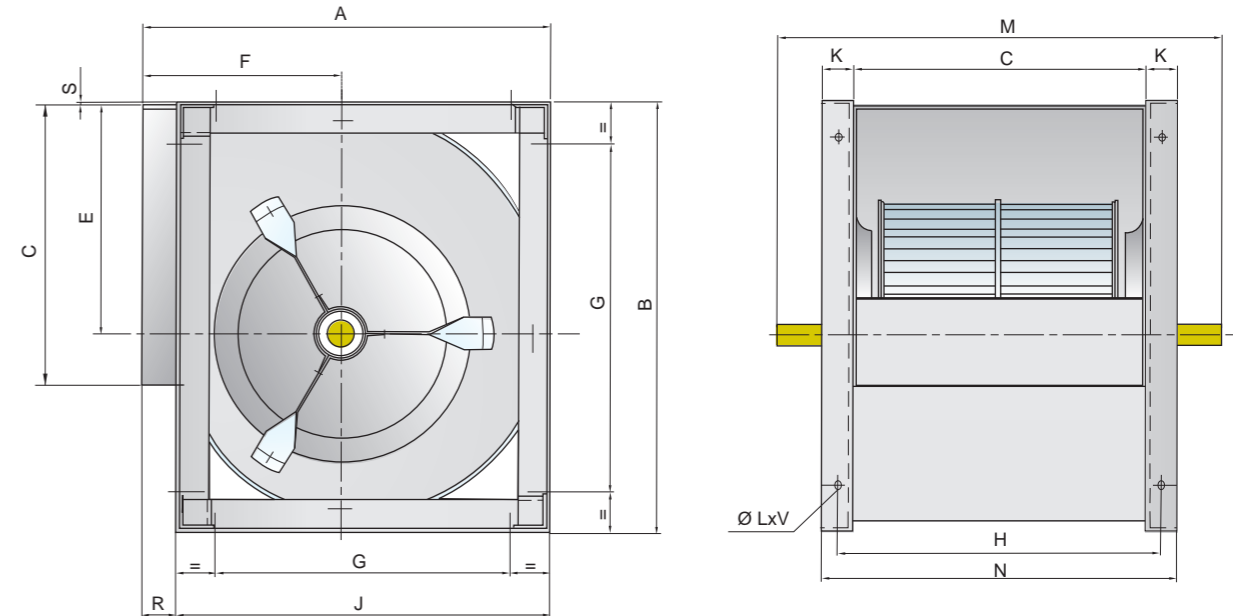

单位: mm

尺寸	型号	A	B	C	E	F	G	H	J	K	M	N	R	S	t	t1	W	X	Φd	LxV
200		343	370	256	215	164	224	281	306	25	420	306	37	4	6	6	40	22.5	20	11x16
225		383	415	288	243	180	224	313	348	25	460	338	35	3	6	6	50	22.5	20	11x16
250		419	461	322	270	195	224	347	384	25	490	372	35	4	6	6	50	22.5	20	11x16
280		466	518	361	302	215	280	391	432	30	555	421	34	5	8	7	40	28	25	13x18
315		518	578	404	340	236	280	434	480	30	600	464	38	3	8	7	40	28	25	13x18
355		578	655	453	383	261	355	493	548	40	675	533	30	6	8	7	65	33	30	13x18
400		651	736	507	431.5	290	355	547	613	40	725	587	38	4.5	8	7	65	33	30	13x18
450		726	827	569	486	322	530	609	681	40	815	649	45	5	10	8	70	38	35	13x18
500		800	914	638	538	352	530	678	750	40	885	718	50	5	10	8	50	38	35	13x18
560		893	1030	715	602	390	530	765	845	50	1000	815	48	8	12	8	70	43	40	13x18
630		999	1157	801	678.5	434	530	851	946	50	1090	901	53	7	14	9	70	48.5	45	13x18
710		1121	1303	898	765	485	630	948	1058	50	1255	998	63	7	14	9	90	53.5	50	17x22

SYD-K

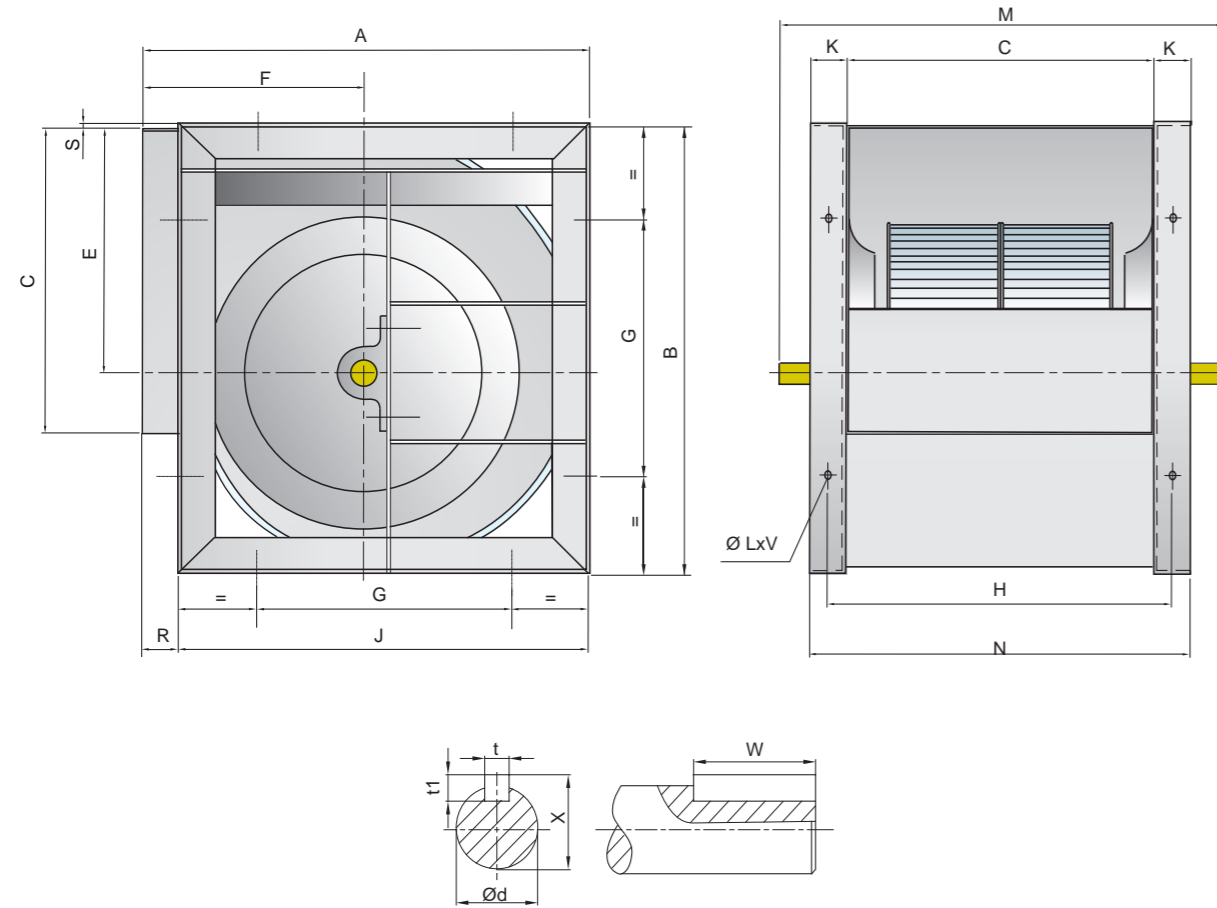

单位: mm

型号 尺寸	A	B	C	E	F	G	H	J	K	M	N	R	S	t	t1	W	X	Φd	LxV
280	466	518	361	302	215	280	391	432	30	580	421	34	5	8	7	40	33	30	13x18
315	518	578	404	340	236	280	434	480	30	625	464	38	3	8	7	40	33	30	13x18
355	578	655	453	383	261	355	493	548	40	685	533	30	6	10	8	50	38	35	13x18
400	651	736	507	431.5	290	355	547	613	40	790	587	38	4.5	10	8	70	38	35	13x18
450	726	827	569	486	322	530	609	681	40	850	649	45	5	12	8	70	43	40	13x18
500	800	918	638	538	352	530	678	750	40	920	718	50	5	12	8	70	43	40	13x18
560	893	1030	715	602	390	530	765	845	50	1070	815	48	8	14	9	90	53.5	50	13x18
630	999	1157	801	678.5	434	530	851	946	50	1155	901	53	7	14	9	90	53.5	50	13x18
710	1121	1303	898	765	485	630	948	1058	50	1290	998	63	7	18	11	90	64	60	17x22
800	1250	1468	1007	862	535	710	1057	1181	50	1450	1107	69	7	18	11	90	64	60	17x22
900	1408	1648	1130	971	604	800	1180	1319	60	1570	1250	89	9	18	11	100	64	60	17x22
1000	1541	1810	1267	1066	657	900	1317	1462	60	1700	1387	79	9	18	11	100	64	60	17x22

SYD-R2

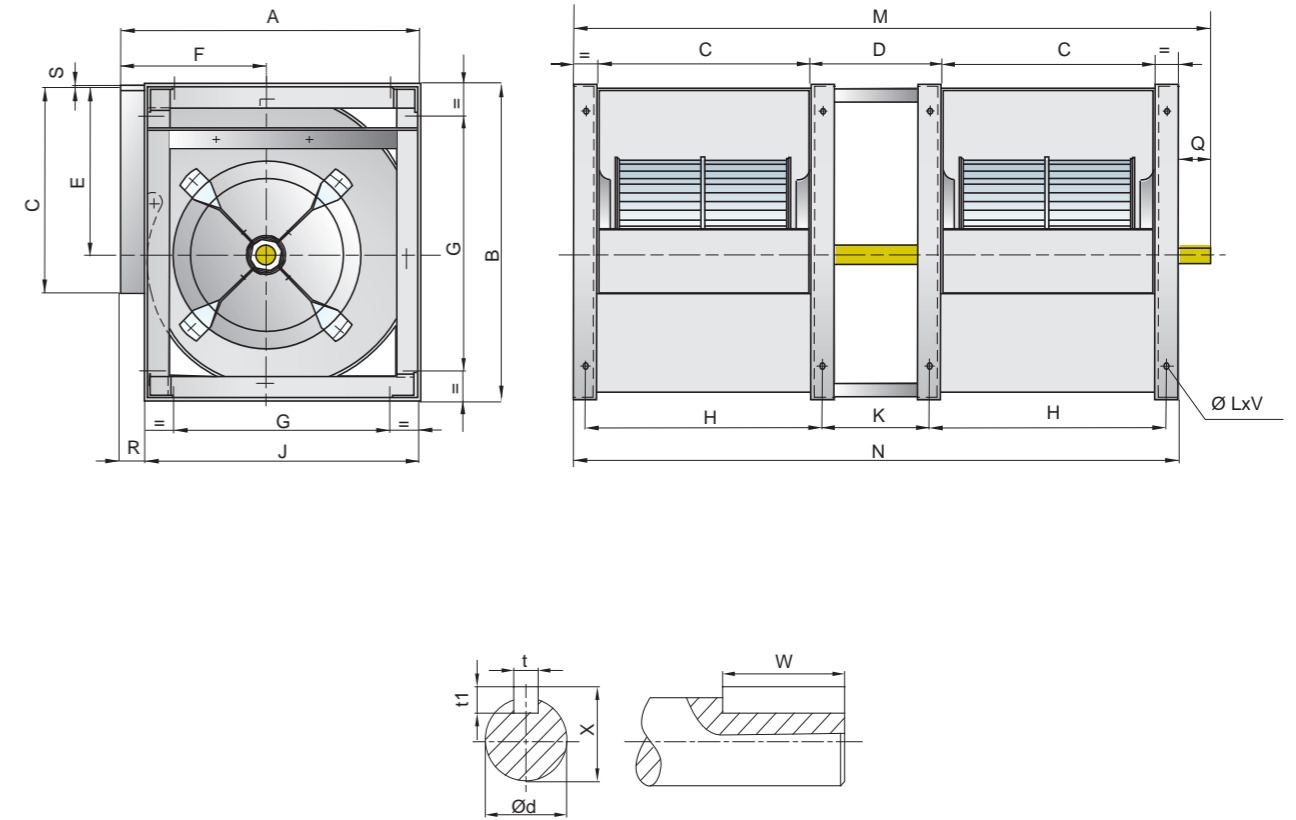

单位: mm

型号 尺寸	A	B	C	D	E	F	G	H	J	K	M	N	Q	R	S	t	t1	W	X	Φd	LxV
280	466	518	361	280	302	215	280	391	432	250	1140	1062	78	34	5	8	7	60	33	30	13x18
315	518	578	404	315	340	236	280	434	480	285	1263	1183	80	38	3	8	7	60	33	30	13x18
355	578	655	453	355	383	261	355	493	548	315	1431	1341	90	30	6	10	8	50	38	35	13x18
400	650	736	507	400	432	290	355	547	612	360	1582	1494	98	38	4	10	8	50	38	35	13x18
450	726	827	569	450	486	322	530	609	681	410	1768	1668	100	45	5	12	8	70	43	40	13x18
500	800	918	638	500	538	352	530	678	750	460	1956	1856	100	50	5	12	8	70	43	40	13x18

SYD-K2

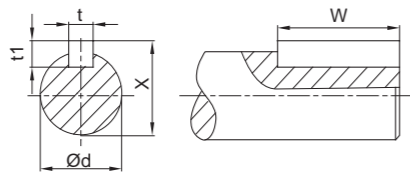
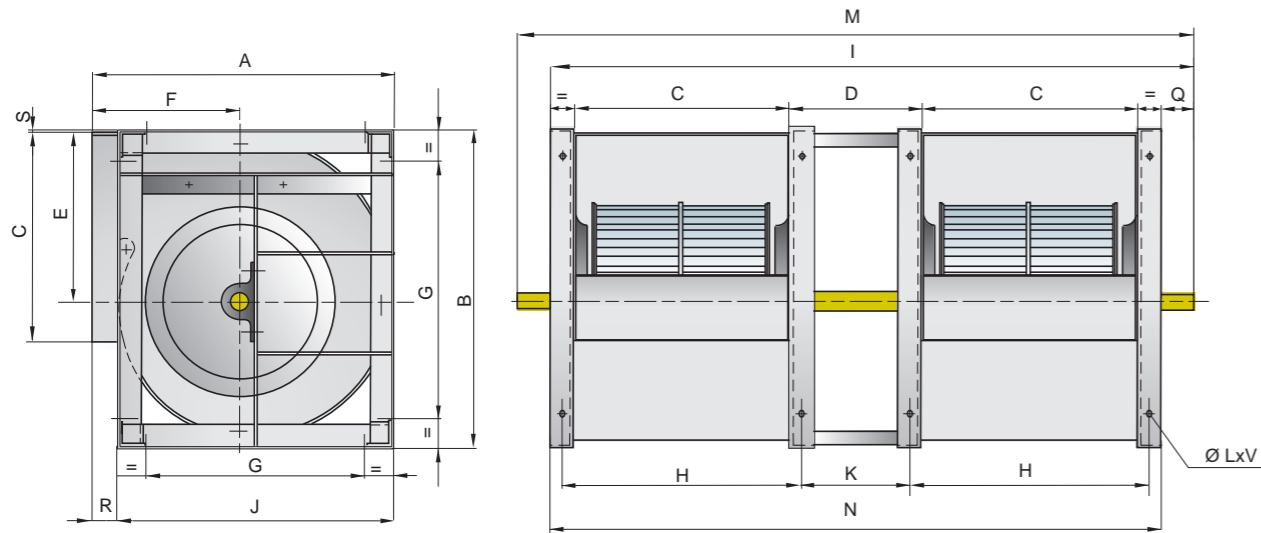

单位: mm

型号 尺寸	A	B	C	D	E	F	G	H	I	J	K	M	N	Q	R	S	t	t1	φd	W	X	LxV
355	578	655	453	355	383	261	355	493	1451	548	315	\	1341	110	30	6	12	8	40	70	43	13x18
400	651	736	507	400	432	290	355	547	1604	613	360	\	1494	110	38	4.5	12	8	40	70	43	13x18
450	726	827	569	450	486	322	530	609	1803	681	410	\	1668	135	45	5	14	9	45	90	48.5	13x18
500	800	918	638	500	538	352	530	678	1991	750	460	\	1856	135	50	5	14	9	50	90	53.5	13x18

注: 型号SYD355K与SYD500K为单出轴。

SYD-L

		0°			90°			180°		
左旋 LG Left Hand										
右旋 RD Right Hand										
型号 Model	电机机座型号 Motor Frame Size	A	B	C	A	B	C	A	B	C
200	56	730	420	404	730	420	358	730	420	406
	63	730	420	404	730	420	358	730	420	406
	71	730	420	404	730	420	358	730	420	406
	80	730	420	404	730	420	358	730	420	406
225	63	760	460	450	760	460	394	760	460	450
	71	760	460	450	760	460	394	760	460	450
	80	760	460	450	760	460	394	760	460	450
250	90	760	460	450	760	460	394	760	460	450
	63	820	490	484	820	490	422	820	490	482
	71	820	490	484	820	490	422	820	490	482
	80	820	490	484	820	490	422	820	490	482
	90	820	490	484	820	490	422	820	490	482

SYD-R

		0°			90°			180°		
左旋 LG Left Hand										
右旋 RD Right Hand										
型号 Model	电机机座型号 Motor Frame Size	A	B	C	A	B	C	A	B	C
200	56	730	420	404	730	420	358	730	420	406
	63	730	420	404	730	420	358	730	420	406
	71	730	420	404	730	420	358	730	420	406
	80	730	420	404	730	420	358	730	420	406
225	63	760	460	450	760	460	394	760	460	450
	71	760	460	450	760	460	394	760	460	450
	80	760	460	450	760	460	394	760	460	450
250	90	760	460	450	760	460	394	760	460	450
	63	820	490	484	820	490	422	820	490	482
	71	820	490	484	820	490	422	820	490	482
	80	820	490	484	820	490	422	820	490	482
	90	820	490	484	820	490	422	820	490	482



SYD-R

		0°			90°			180°		
左旋 LG Left Hand										
右旋 RD Right Hand										
型号 Model	电机机座型号 Motor Frame Size	A	B	C	A	B	C	A	B	C
280	71	940	575	568	940	575	516	940	575	568
	80	940	575	568	940	575	516	940	575	568
	90	940	575	568	940	575	516	940	575	568
	100	940	575	568	940	575	516	940	575	568
	112	940	575	568	940	575	516	940	575	568
	132	940	575	568	940	575	516	940	575	568
315	71	1040	630	628	1040	640	568	1040	640	628
	80	1040	640	628	1040	640	568	1040	640	628
	90	1040	640	628	1040	640	568	1040	640	628
	100	1040	640	628	1040	640	568	1040	640	628
	112	1040	640	628	1040	640	568	1040	640	628
	132	1040	640	628	1040	640	568	1040	640	628
355	71	1110	700	705	1110	700	628	1110	700	705
	80	1110	700	705	1110	700	628	1110	700	705
	90	1110	700	705	1110	700	628	1110	700	705
	100	1110	700	705	1110	700	628	1110	700	705
	112	1110	700	705	1110	700	628	1110	700	705
	132	1110	700	705	1110	700	628	1110	700	705
400	71	1250	760	786	1250	760	701	1250	760	786
	80	1250	760	786	1250	760	701	1250	760	786
	90	1250	760	786	1250	760	701	1250	760	786
	100	1250	760	786	1250	760	701	1250	760	786
	112	1250	760	786	1250	760	701	1250	760	786
	132	1250	760	786	1250	760	701	1250	760	786
450	71	1340	845	877	1340	845	776	1340	845	877
	80	1340	845	877	1340	845	776	1340	845	877
	90	1340	845	877	1340	845	776	1340	845	877
	100	1340	845	877	1340	845	776	1340	845	877
	112	1340	845	877	1340	845	776	1340	845	877
	132	1340	845	877	1340	845	776	1340	845	877
	160	1340	845	877	1340	845	776	1340	845	877

SYD-R

		0°			90°			180°		
左旋 LG Left Hand										
右旋 RD Right Hand										
型号 Model	电机机座型号 Motor Frame Size	A	B	C	A	B	C	A	B	C
500	80	1420	915	981	1420	915	863	1420	915	981
	90	1420	915	981	1420	915	863	1420	915	981
	100	1420	915	981	1420	915	863	1420	915	981
	112	1420	915	981	1420	915	863	1420	915	981
	132	1420	915	981	1420	915	863	1420	915	981
	160	1420	915	981	1420	915	863	1420	915	981
	80	1420	915	981	1420	915	863	1420	915	981
560	80	1580	1000	1093	1580	1000	956	1580	1000	1093
	90	1580	1000	1093	1580	1000	956	1580	1000	1093
	100	1580	1000	1093	1580	1000	956	1580	1000	1093
	112	1580	1000	1093	1580	1000	956	1580	1000	1093
	132	1580	1000	1093	1580	1000	956	1580	1000	1093
	160	1580	1000	1093	1580	1000	956	1580	1000	1093
630	90	1770	1090	1220	1770	1090	1062	1770	1090	1220
	100	1770	1090	1220	1770	1090	1062	1770	1090	1220
	112	1770	1090	1220	1770	1090	1062	1770	1090	1220
	132	1770	1090	1220	1770	1090	1062	1770	1090	1220
	160	1770	1090	1220	1770	1090	1062	1770	1090	1220
	180	1770	1090	1220	1770	1090	1062	1770	1090	1220
710	100	1950	1255	1366	1950	1255	1184	1950	1255	1366
	112	1950	1255	1366	1950	1255	1184	1950	1255	1366
	132	1950	1255	1366	1950	1255	1184	1950	1255	1366
	160	1950	1255	1366	1950	1255	1184	1950	1255	1366
	180	1950	1255	1366	1950	1255	1184	1950	1255	1366

SYD-K

		0°			90°			180°		
左旋 LG Left Hand										
右旋 RD Right Hand										
型号 Model	电机机座型号 Motor Frame Size	A	B	C	A	B	C	A	B	C
280	90	940	600	568	940	600	516	940	600	568
	100	940	600	568	940	600	516	940	600	568
	112	940	600	568	940	600	516	940	600	568
	132	940	600	568	940	600	516	940	600	568
	160	940	600	568	940	600	516	940	600	568
315	100	1040	665	628	1040	665	568	1040	665	628
	112	1040	665	628	1040	665	568	1040	665	628
	132	1040	665	628	1040	665	568	1040	665	628
	160	1040	665	628	1040	665	568	1040	665	628
	180	1040	665	628	1040	665	568	1040	665	628
355	100	1110	725	705	1110	725	628	1110	725	705
	112	1110	725	705	1110	725	628	1110	725	705
	132	1110	725	705	1110	725	628	1110	725	705
	160	1110	725	705	1110	725	628	1110	725	705
	180	1110	725	705	1110	725	628	1110	725	705
400	100	1250	790	786	1250	790	701	1250	790	786
	112	1250	790	786	1250	790	701	1250	790	786
	132	1250	790	786	1250	790	701	1250	790	786
	160	1250	790	786	1250	790	701	1250	790	786
	180	1250	790	786	1250	790	701	1250	790	786
450	100	1340	845	877	1340	845	776	1340	845	877
	112	1340	890	877	1340	890	776	1340	890	877
	132	1340	890	877	1340	890	776	1340	890	877
	160	1340	890	877	1340	890	776	1340	890	877
	180	1340	890	877	1340	890	776	1340	890	877
	200	1340	890	877	1340	890	776	1340	890	877
500	100	1420	915	981	1420	915	863	1420	915	981
	112	1420	960	981	1420	960	863	1420	960	981
	132	1420	960	981	1420	960	863	1420	960	981
	160	1420	960	981	1420	960	863	1420	960	981
	180	1420	960	981	1420	960	863	1420	960	981
	200	1420	960	981	1420	960	863	1420	960	981

SYD-K

		0°			90°			180°		
左旋 LG Left Hand										
右旋 RD Right Hand										
型号 Model	电机机座型号 Motor Frame Size	A	B	C	A	B	C	A	B	C
560	132	1580	1070	1093	1580	1070	956	1580	1070	1093
	160	1580	1070	1093	1580	1070	956	1580	1070	1093
	180	1580	1070	1093	1580	1070	956	1580	1070	1093
	200	1580	1070	1093	1580	1070	956	1580	1070	1093
630	132	1770	1155	1220	1770	1155	1062	1770	1155	1220
	160	1770	1155	1220	1770	1155	1062	1770	1155	1220
	180	1770	1155	1220	1770	1155	1062	1770	1155	1220
	200	1770	1155	1220	1770	1155	1062	1770	1155	1220
710	132	1950	1290	1366	1950	1290	1284	1950	1290	1366
	160	1950	1290	1366	1950	1290	1284	1950	1290	1366
	180	1950	1290	1366	1950	1290	1284	1950	1290	1366
	200	1950	1290	1366	1950	1290	1284	1950	1290	1366
800	100	2130	1450	1548	2130	1450	1330	2130	1450	1548
	112	2130	1450	1548	2130	1450	1330	2130	1450	1548
	132	2130	1450	1548	2130	1450	1330	2130	1450	1548
	160	2130	1450	1548	2130	1450	1330	2130	1450	1548
	180	2130	1450	1548	2130	1450	1330	2130	1450	1548
	200	2130	1450	1548	2130	1450	1330	2130	1450	1548
900	112	2450	1570	1748	2450	1570	1508	2450	1570	1748
	132	2450	1570	1748	2450	1570	1508	2450	1570	1748
	160	2450	1570	1748	2450	1570	1508	2450	1570	1748
	180	2450	1570	1748	2450	1570	1508	2450	1570	1748
	200	2450	1570	1748	2450	1570	1508	2450	1570	1748
	225	2450	1570	1748	2450	1570	1508	2450	1570	1748
1000	112	2650	1700	1910	2650	1700	1641	2650	1700	1910
	132	2650	1700	1910	2650	1700	1641	2650	1700	1910
	160	2650	1700	1910	2650	1700	1641	2650	1700	1910
	180	2650	1700	1910	2650	1700	1641	2650	1700	1910
	200	2650	1700	1910	2650	1700	1641	2650	1700	1910
	225	2650	1700	1910	2650	1700	1641	2650	1700	1910

SYD-R

		0°			90°			180°		
左旋 LG Left Hand										
右旋 RD Right Hand										
型号 Model	电机机座型号 Motor Frame Size	A	B	C	A	B	C	A	B	C
280	71	840	612	568	840	612	516	840	612	568
	80	840	612	568	840	612	516	840	612	568
	90	840	612	568	840	612	516	840	612	568
	100	840	612	568	840	612	516	840	612	568
	112	840	612	568	840	612	516	840	612	568
315	71	880	617	628	880	617	568	880	617	628
	80	880	617	628	880	617	568	880	617	628
	90	880	617	628	880	617	568	880	617	628
	100	880	617	628	880	617	568	880	617	628
	112	880	617	628	880	617	568	880	617	628
355	71	940	655	705	940	655	628	940	655	705
	80	940	655	705	940	655	628	940	655	705
	90	940	655	705	940	655	628	940	655	705
	100	940	655	705	940	655	628	940	655	705
	112	940	655	705	940	655	628	940	655	705
400	80	1130	736	786	1130	736	613	1130	736	786
	90	1130	736	786	1130	736	613	1130	736	786
	100	1130	736	786	1130	736	613	1130	736	786
	112	1130	736	786	1130	736	613	1130	736	786
	132	1130	736	786	1130	736	613	1130	736	786
450	90	1210	827	877	1210	827	776	1210	827	877
	100	1210	827	877	1210	827	776	1210	827	877
	112	1210	827	877	1210	827	776	1210	827	877
	132	1210	827	877	1210	827	776	1210	827	877
500	90	1290	918	981	1290	918	863	1290	918	981
	100	1290	918	981	1290	918	863	1290	918	981
	112	1290	918	981	1290	918	863	1290	918	981
	132	1290	918	981	1290	918	863	1290	918	981
	160	1290	918	981	1290	918	863	1290	918	981
560	90	1410	1030	1093	1410	1030	956	1410	1030	1093
	100	1410	1030	1093	1410	1030	956	1410	1030	1093
	112	1410	1030	1093	1410	1030	956	1410	1030	1093
	132	1410	1030	1093	1410	1030	956	1410	1030	1093
	160	1410	1030	1093	1410	1030	956	1410	1030	1093

SYD-R

		0°			90°			180°		
左旋 LG Left Hand										
右旋 RD Right Hand										
型号 Model	电机机座型号 Motor Frame Size	A	B	C	A	B	C	A	B	C
630	90	1510	1157	1220	1510	1157	1062	1510	1157	1220
	100	1510	1157	1220	1510	1157	1062	1510	1157	1220
	112	1510	1157	1220	1510	1157	1062	1510	1157	1220
	132	1510	1157	1220	1510	1157	1062	1510	1157	1220
	160	1730	1303	1366	1730	1303	1491	1730	1303	1366
710	100	1730	1303	1366	1730	1303	1491	1730	1303	1366
	112	1730	1303	1366	1730	1303	1491	1730	1303	1366
	132	1730	1303	1366	1730	1303	1491	1730	1303	1366
	160	1730	1303	1366	1730	1303	1491	1730	1303	1366
	180	1730	1303	1366	1730	1303	1491	1730	1303	1366

SYD-K

		0°			90°			180°		
左旋 LG Left Hand										
右旋 RD Right Hand										
型号 Model	电机机座型号 Motor Frame Size	A	B	C	A	B	C	A	B	C
280	100	840	612	568	840	612	516	840	612	568
	112	840	612	568	840	612	516	840	612	568
	132	840	612	568	840	612	516	840	612	568
315	100	880	617	628	880	617	568	880	617	628
	112	880	617	628	880	617	568	880	617	628
	132	880	617	628	880	617	568	880	617	628
	160	880	617	628	880	617	568	880	617	628
	100	940	655	705	940	655	628	940	655	705
355	112	940	655	705	940	655	628	940	655	705
	132	940	655	705	940	655	628	940	655	705
	160	940	655	705	940	655	628	940	655	705
400	112	1130	736	786	1130	736	613	1130	736	786
	132	1130	736	786	1130	736	613	1130	736	786
	160	1130	736	786	1130	736	613	1130	736	786



SYD-K

		0°			90°			180°		
左旋 LG Left Hand										
右旋 RD Right Hand										
型号 Model	电机机座型号 Motor Frame Size	A	B	C	A	B	C	A	B	C
450	112	1210	827	877	1210	827	776	1210	827	877
	132	1210	827	877	1210	827	776	1210	827	877
	160	1210	827	877	1210	827	776	1210	827	877
	180	1210	827	877	1210	827	776	1210	827	877
500	112	1290	918	981	1290	918	863	1290	918	981
	132	1290	918	981	1290	918	863	1290	918	981
	160	1290	918	981	1290	918	863	1290	918	981
	180	1290	918	981	1290	918	863	1290	918	981
560	132	1410	1030	1093	1410	1030	956	1410	1030	1093
	160	1410	1030	1093	1410	1030	956	1410	1030	1093
	180	1410	1030	1093	1410	1030	956	1410	1030	1093
	200	1410	1030	1093	1410	1030	956	1410	1030	1093
630	132	1510	1157	1220	1510	1157	1062	1510	1157	1220
	160	1510	1157	1220	1510	1157	1062	1510	1157	1220
	180	1510	1157	1220	1510	1157	1062	1510	1157	1220
	200	1510	1157	1220	1510	1157	1062	1510	1157	1220
710	132	1730	1303	1366	1730	1303	1491	1730	1303	1366
	160	1730	1303	1366	1730	1303	1491	1730	1303	1366
	180	1730	1303	1366	1730	1303	1491	1730	1303	1366
	200	1730	1303	1366	1730	1303	1491	1730	1303	1366
	225	1730	1303	1366	1730	1303	1491	1730	1303	1366
800	132	1870	1468	1548	1870	1468	1330	1870	1468	1548
	160	1870	1468	1548	1870	1468	1330	1870	1468	1548
	180	1870	1468	1548	1870	1468	1330	1870	1468	1548
	200	1870	1468	1548	1870	1468	1330	1870	1468	1548
	225	1870	1468	1548	1870	1468	1330	1870	1468	1548
900	160	2170	1648	1748	2170	1648	1748	2170	1648	1748
	180	2170	1648	1748	2170	1648	1748	2170	1648	1748
	200	2170	1648	1748	2170	1648	1748	2170	1648	1748
	225	2170	1648	1748	2170	1648	1748	2170	1648	1748
1000	160	2300	1810	1910	2300	1810	1641	2300	1810	1910
	180	2300	1810	1910	2300	1810	1641	2300	1810	1910
	200	2300	1810	1910	2300	1810	1641	2300	1810	1910
	225	2300	1810	1910	2300	1810	1641	2300	1810	1910
	250	2300	1810	1910	2300	1810	1641	2300	1810	1910

SYD系列风机运行极限

SYD Series Fan Operating Limits

			200	225	250	280	315	355	400	450	500	560	630	710	800	900	1000
极限吸收功率 Max.Absorbed Power	L	Kw	3	3	4	/	/	/	/	/	/	/	/	/	/	/	/
	R	Kw	3	3	4	4	6	6	8	10	10	10	15	15	/	/	/
	K	Kw	/	/	/	6	10	15	20	20	20	30	30	40	40	60	60
	R2	Kw	/	/	/	9	13	13	18	22	22	/	/	/	/	/	/
极限转速 Max.Speed	K2	Kw	/	/	/	/	/	33	45	45	45	/	/	/	/	/	/
	L	rmp	3200	2800	2400	/	/	/	/	/	/	/	/	/	/	/	/
	R	rmp	3200	2800	2400	2200	1900	1600	1400	1300	1100	900	800	700	/	/	/
	K	rmp	/	/	/	2500	2200	2000	1800	1600	1300	1200	1000	900	800	700	600
极限温度 (最低-20°C) Air Temperature Limits (Min-20°C)	R2	rmp	/	/	/	1800	1600	1400	1200	1000	900	/	/	/	/	/	/
	K2	rmp	/	/	/	/	/	1600	1400	1200	1000	/	/	/	/	/	/
	L	Max°C	85	85	85	/	/	/	/	/	/	/	/	/	/	/	/
	R	Max°C	85	85	85	85	85	85	85	85	85	85	85	85	85	85	85
风机质量 Fan Weight	K	Max°C	/	/	/	85	85	85	85	85	85	85	85	85	85	85	85
	R2	Max°C	/	/	/	/	/	85	85	85	85	/	/	/	/	/	/
	K2	Max°C	/	/	/	/	/	85	85	85	85	/	/	/	/	/	/
	L	Kg	7.4	9.2	11	/	/	/	/	/	/	/	/	/	/	/	/
风机质量 Fan Weight	R	Kg	9.4	10.8	13	19	25	36	44	57	71.5	131	156	192	/	/	/
	K	Kg	/	/	/	29	35	42	57	72	92	160	185	240	290	365	480
	R2	Kg	/	/	/	38	50	71	87	113	142	/	/	/	/	/	/
	K2	Kg	/	/	/	/	/	85	107	136	175	/	/	/	/	/	/

本样本中所述的风机特性,如尺寸、性能参数等,本公司保留更改的权利,恕不另行通知;如有不明之处,请来电询问。  
This fan features described in the sample, such as size, performance parameters, the Company reserves the right to change without notice; if unknown place, please call us.

## SYQ 系列离心式空调风机

Centrifugal Ventilators

浙江亿利达风机股份有限公司特此证明，此处所示 SYQ 系列离心风机获得了加盖 AMCA 印章的授权。所示额定值系根据 AMCA 出版物 211 和 AMCA 出版物 311 所进行测试和程序确定，并符合 AMCA 认证额定值计划的要求。

这里描述的所有离心风机都已经取得了 AMCA 印章，他们的认证数据见第 103 页到 117 页。

Zhejiang Yilida Ventilator Co.,Ltd. certifies that the SYQ Series fans shown herein are licensed to bear the AMCA Seal. The ratings shown are based on tests and procedures performed in accordance with AMCA Publication 211 and AMCA Publication 311 and comply with the requirements of the AMCA Certified Ratings Program.

All the Centrifugal Fans described herein are licensed to bear the AMCA Seal, and their certified ratings are shown on pages 103 through 117.

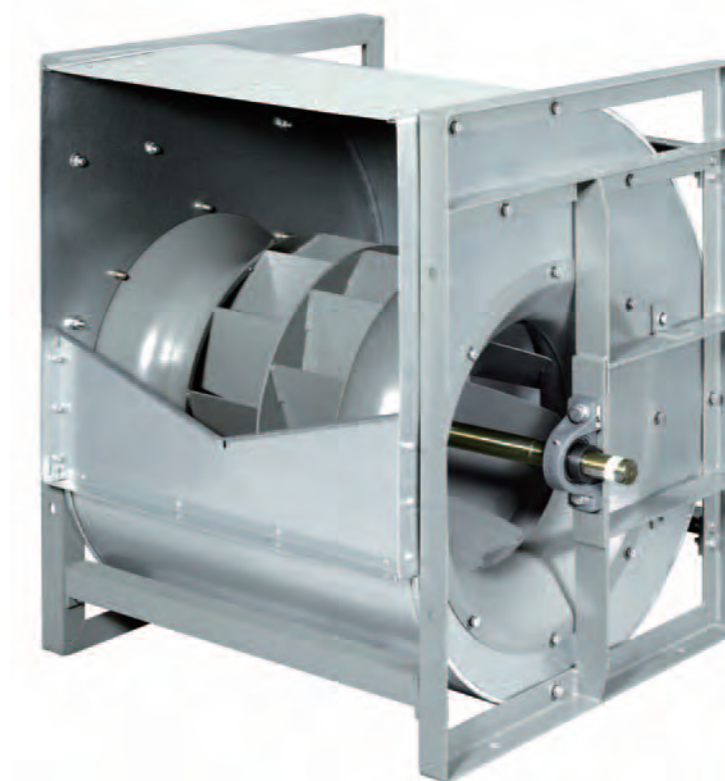

概述

SYQ 系列后向离心式空调风机采用国际同类产品先进技术自行开发生产，通过了 AMCA 国际认证并取得 AMCA 印章。该样本中列出的 15 种规格风机，流量范围从 1000m<sup>3</sup>/h-120000 m<sup>3</sup>/h，全压从 200Pa-3000Pa。SYQ 系列风机采用直板式叶轮，具有效率高、噪音低、耗能少、通用性强、安全性好等特点。广泛应用于各类中央空调机组及其它暖通空调、净化、通风等空调系统。

Summary

The SYQ Series of centrifugal fans with backward blade were developed with advanced technologies. They are licensed to bear the AMCA Seal for air performance, sound, and FEG. The SYQ Series includes 15 models as described in this catalogue. The volume flow of the SYQ Series ranges from 1,000 m<sup>3</sup>/h to 120,000 m<sup>3</sup>/h, the total pressure ranges from 200 Pa to 3,000 Pa. Some of the features and characteristics of these fans are: forward impeller blades, a wide range of applications, high efficiency, low noise, and low power consumption. These fans are ideal for use in central air-conditioning systems, in purifiers. They are also suitable for use in a variety of other ventilation applications.

命名方式

SYQ 500 R

Nomenclature

结构型式 Construction type  
L,R 型(基本型) Type L, R (Basic Model)  
K 型(加强型) Type K (Heavy Duty Model)  
Z 型(超重型) Type Z (Extra-heavy Duty Model)

叶轮名义直径( mm)  
Nominal diameter of impeller (mm)

后向单板式离心风机系列代号  
Fan series with backward blades

产品型式

1. 旋向

SYQ 系列风机可分为左旋(LG)和右旋(RD)两种旋转方式，从风机皮带轮一端正视，叶轮顺时针旋转的称为右旋风机，逆时针旋转的称为左旋风机。皮带轮可分为左右调向，

1. Rotation

SYQ series fans have two direction of rotations, left-hand rotation (LG) and right-hand rotation (RD); Viewing from drive side, if the impeller rotates clockwise, it is left hand (LG) rotation. If the impeller rotates counter clockwise, it is right-hand (RD).

2. 出风口方向

SYQ 系列出风口可按图 1 所示制成 0°、90°、180°、270° 四种出风方向。

2. Discharge Direction

As shown in Fig1, SYQ Series fans can be constructed in four discharge directions: 0°, 90°, 180°, and 270°.

图1 (Fig 1)

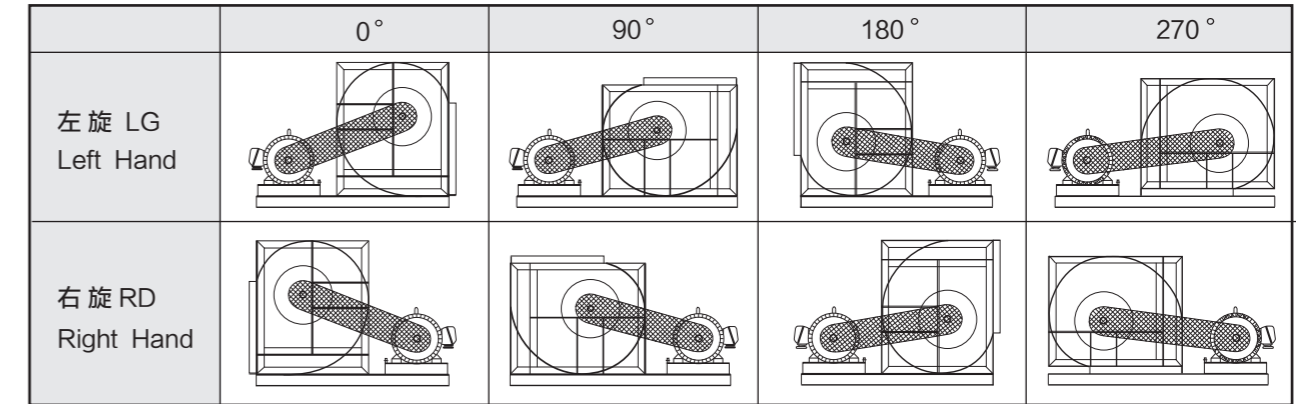

3. 结构形式

SYQ 系列风机可按图 2 所示制成 L 型、R 型、K 型、Z 型、L2 型、R2 型。

3. type of Construction

As shown in Fig 2, SYQ series fans can be divided into category L, R, K, Z, category R2, K2.

图2 (Fig 2)

风机类型 Fan Type	机号 Fan Size	风机示意图 Fan Diagram	轴承实物图 Bearing Type
L 型 TYPE L	200-250		
R 型 TYPE R	200-250		
R 型 TYPE R	280-710		
K、Z 型 TYPE K,Z	280-1000		
R2 型 TYPE R2	200-500		
K2 型 TYPE K2	200-560		



## 产品结构

SYQ 系列风机主要由机壳、叶轮、框架、轴承及轴构成。出口法兰（为可选件）。

### 1. 机壳

机壳采用热镀锌钢板制造，侧板具有符合空气动力的外形，进风口整体拉伸成型，蜗板采用点焊或“Pittsburg seam locking”的连接方式与侧板连成一体。

### 2. 叶轮

后向叶轮采用优质冷轧钢板制成，按三元流理论设计的平板式叶片焊接在高精度激光切割机床加工的中盘和端圈上，整体喷塑。所有叶轮进行静平衡和动平衡测试，内控精度达到 G2.5 级 (ANSI/AMCA 204-05)。

### 3. 框架

L、R 型风机框架采用热镀锌钢板剪切、折弯制成，TOX 连接保证了所需的尺寸精度和应有的刚度；K 型风机框架由角钢和扁钢冷弯焊接制成；Z 型风机框架由加宽加厚的角钢扁钢焊接制成。轴承安装位进行对称铣平面加工，表面喷塑处理，以保证足够的刚度和强度，同时保证安装轴和轴承的同轴度。

### 4. 轴承

SYQ 系列风机均采用优质滚珠轴承，并根据噪声最低来选择，该轴承设有加润滑油的孔，已预先加润滑油并自动对中；L/R 型风机的轴承安装在轴承支架上，并设有防振垫圈；K 型风机则采用带座向心球轴承；Z 型风机采用重载荷的双列滚柱轴承的轴承箱结构。轴承寿命为 L10 ≥ 100000 小时。

### 5. 轴

风机轴采用 40Cr 低合金钢，经车、调质热处理、磨削制成，强度高，挠度小，严格控制轴径尺寸公差及形位公差，每根轴均经过涂覆防锈处理。轴尺寸设计应满足第一临界转速至少为风机最大运行转速的 1.4 倍。

### 6. 出口风法兰

法兰采用热镀锌钢板制成，法兰与蜗壳的连接采用 TOX 免焊工艺，外观精美，并具有足够的刚度与强度。

## Construction of Product

SYQ series fans are mainly constructed of housing, impeller, frame, bearing and shaft. Outlet flange (is optional).

### 1. Housing

The housing is made of hot galvanized steel sheet. The side plates include inlets cones that are designed with the best aerodynamics for inlet condition. The scroll is fixed to the side plates by spot welding or "Pittsburg seam locking."

### 2. Impeller

Backwards curved airfoil impeller is constructed of high-grade cold-roll steel sheets, according to the three-dimensional flow theory, the impeller is fixed on the center plate and on the end ring with welding by high precision laser cutting machine. The unity of the impeller is spraying by plastic. All impellers are balanced to ANSI/AMCA Standard 204-05. Yilida's internal standard is G2.5 or higher for wheel balancing.

### 3. Frame

The frames for type L and R construction are made of galvanized steel angle iron bars. The cutting and bending of the frame parts, as well as the TOX connections, are formed with the use of toolings to ensure the high accuracy and the rigidity of the frames; The frames for K constructions are welded by angle steel and flat steel, the frames for Z constructions are welded by thicker angle steel and flat steel, and finished with polyester coating in order to ensure sufficient rigidity and strength. The bearing supports are machined to ensure proper installation and alignments of the bearings.

### 4. Bearings

Ball bearings are used in all of the SYQ Series fans. These are high-quality bearings and selected to minimize the fan noise levels. The bearings are pre-lubricated, sealed, and self-centering. For type R and L constructions, the bearings are supplied with lubrication fittings. For type K constructions, the bearings are supplied with radial bearing. For type Z, the bearings are supplied with heavy lift double-row ball bearing. Yilida bearing service life (L10) are over 100,000 hours (L10 ≥ 100000 hours).

### 5. Shaft

The shafts are made of 40 Cr carbon steel bars. The shafts are rough machined and then stress relieved with heat treatment before final machining. The shaft diameters are machined to very accurate tolerance levels, and they are fully checked to ensure precision fit. Each shaft is made turned, ground and polished. They are coated after assembly to provide corrosion resistance. Shaft size should be designed to meet the first critical speed of at least fan maximum running speed 1.4 times.

### 6. Outlet Flange

The outlet flange is made of galvanized steel. The connections of the flange components to the scroll are made using a TOX non-welding process. This maintains a good flange appearance while also providing sufficient strength and rigidity.

## 风机性能

### 1. 风机选型示意图例

型号 Type	SYQ500K
风量 Volume	$q_v=16000\text{m}^3/\text{h}$
全压 Total Pressure	$P_{\text{tf}}=1600\text{Pa}$
动压 Dynamic Pressure	$P_{\text{df}}=71\text{Pa}$
出口速度 Outlet Velocity	$C=10.92\text{m/s}$
风机转速 Fan Speed	$n=1977\text{r/min}$
轴功率 Shaft Power	$P_{\text{sh}}=9.43\text{KW}$
A 声功率级 A Sound Power Level	$L_{\text{WA}}=97\text{dB(A)}$
全压效率 Total Efficiency	$\eta_{\text{tf}}=75.4\%$

## Performance Chart

### 1. Fan Performance Curve

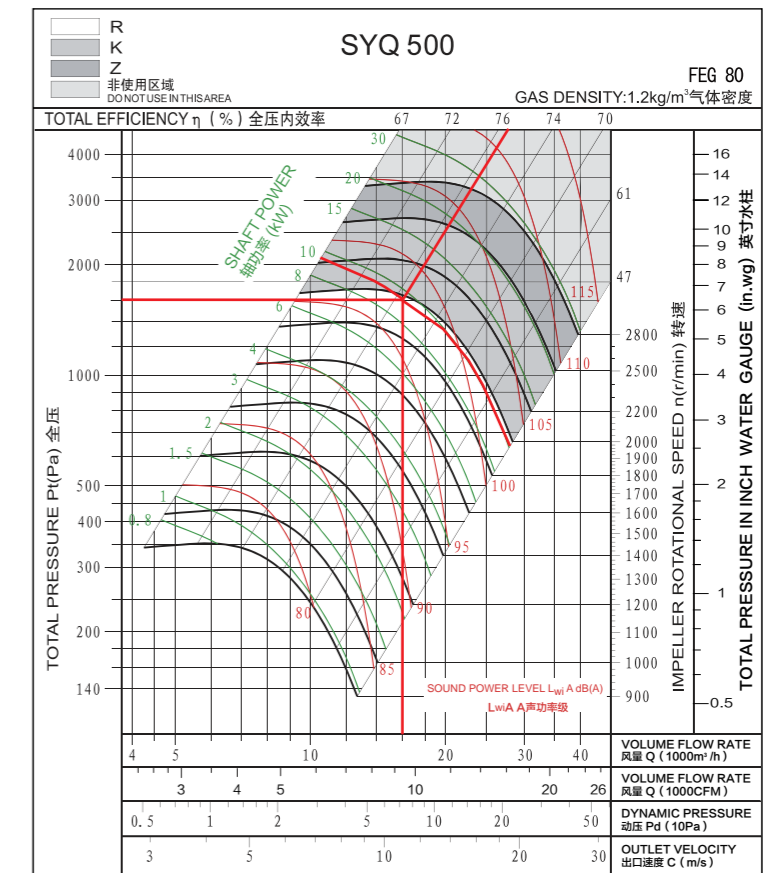

## 2、电机的选配

性能曲线图上的功率 Psh 是指风机轴功率。  
配套电机的功率：Psh.p=Psh × K ÷ ηme  
风机传动效率的取值方法可参照表 1，  
电机容量安全系数的取值方法可参照表 2。

表1 (Table 1)

风机传动方式 Drive Type	η <sub>me</sub>
电机直联传动 Motor direct drive	1
联轴器直联传动 Coupling direct drive	0.98
三角皮带传动 V-belt drive	0.95

## 3.双联风机的性能计算

L2 型、R2 型、K2 型双联风机性能与 L 型、R 型、K 型风机曲线上所示性能比较,在压力相同的情况下,双联风机性能如下:

风量	x2	转速	x1.05
轴功率	x2.15	噪声	+3 dB

双联风机的性能未获得 AMCA International 授权。

## 2. Motor selection

The power (Psh) on the performance chart refers to the shaft power of the fan.  
The rated power of the drive motor equals the total required shaft input multiplied by the safety factor : Psh.p=PshxK+ηme  
The value of mechanical drive efficiency can be obtained from Table 1.  
The required safety factors is provided in Table 2.

表2 (Table 2)

电机功率Power of electric motor (Kw)	K值Value k
≤ 2.2Kw	1.2
≤ 7.5Kw	1.15
≥ 11Kw	1.1

## 3. The twin fans' performance calculation is the

double fan performance calculation formula:

Comparing the performance of the twin fan of Category L2 Category R2 and CategoryK2 with the performance of Category L Category R and K in the chart in the same condition of pressure, the twin fans' performance is as the following.

Volume	x2	Speed	x1.05
Shaft Power	x2.15	Noice	+3 dB

Performance of twin fans are not licensed by AMCA International.

8. 关掉风机, 移动电机座以调整张紧度, 当风机工作时, 皮带紧的一边是两个皮带轮连成的一条直线, 松的一边有轻微弧形。

图 3 (Fig3)

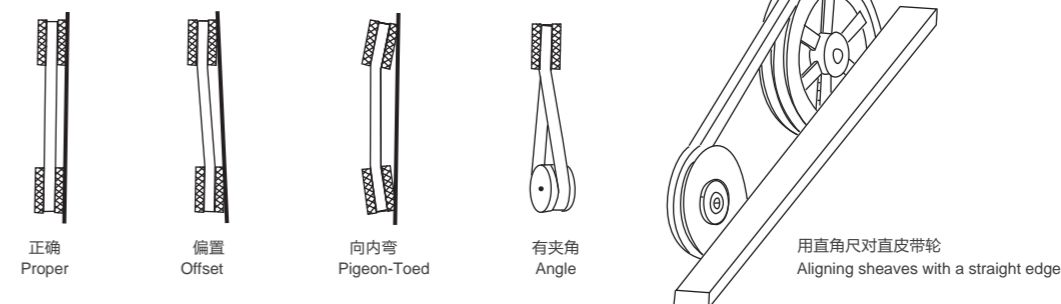

## B) 皮带松紧度

合适的皮带松紧度对使用寿命来说很重要, 太紧会给皮带和轴承带来额外的负载, 降低它们的使用寿命, 太松会出现皮带打滑现象而产生热能并降低使用寿命。

皮带松紧度量具用来判断皮带是否松紧合适。量具本身带有一个尺表, 根据皮带轮中心距和皮带横截面确定皮带张紧力的大小, 如图 4 和表 3。

如没有皮带张紧度量具, 应调节皮带松紧至风机启动时皮带不发生尖叫声为止, 如发生短促的叫是允许的。

拉紧皮带后、开动风机之前, 重新检查皮带轮的对齐情况, 如右必要则重新调整对齐。新皮带在开始使用时可能有点拉伸, 则应在运行几天后重新检查皮带张紧度。

7. Adjust the belt tension until the belts appear snug. Run the unit for a few minutes and allow the belts to set properly.  
8. Switch off the fan, adjust the belt tension by moving the motor base. When in operation, the tight side of the belts should be in a straight line from sheave to sheave and there should be a slight bow on the slack side.

## B) Belt tension

A proper level of belt tension is required in order to obtain a satisfactory belt life. If the belt tension level is too high, excessive loads will be imposed on the belts and the bearing, and this will reduce the lives of both of these components. If the belt tension level is too low, the belt will slip. Belt slippage generates a large amount of heat, and this heat will drastically reduce the life of a belt.

Belt-tensioning gauges can be used to determine whether the belts are tensioned properly. A chart is normally supplied with the gauge which indicates the ranges of forces required to deflect the belts by a given amount to obtain the proper belt tension level. The required forces are based upon the center distance of the sheaves and the belt cross-section. The belts are properly tensioned when the forces required to deflect the belt are within the specified range, see Fig 4 and Table 3. If a belt-tensioning gauge is not available, then the belt should be tightened just enough so that the belt does not squeal when the fan is started. A very short period of noise during the starting of a fans is allowable, but a squeal lasting several seconds or longer is not acceptable. After tensioning the belts and before starting the fan, check to make sure that the sheaves is properly aligned.

Realign the sheaves if necessary. Note that new belts may stretch a little during initial use, so the belt tension level should be checked after a few days of operation.

表3 (Table 3)

皮带截面 Belt Section	使皮带向下移动16mm径向距离1米所需的力 Force required to deflect belt 16mm per metre of span		
	张紧力 (小皮带轮直径) Small Pulley/Diameter (mm)	牛顿 Newloman (N)	千克力 Kilogram force (Kgf)
SPZ	56-95	13-20	1.3-2.0
	100-140	20-25	2.0-2.5
SPA	80-132	25-35	2.5-3.6
	140-200	35-45	3.6-4.6
SPB	112-224	45-65	4.6-6.6
	236-315	65-85	6.6-8.7
SPC	224-335	85-115	8.7-11.7
	375-560	115-150	11.7-15.3
A	80-140	10-15	1.1-1.5
B	125-200	20-30	2.0-3.1

图 4 (Fig4)

与中心距有关的皮带张紧度指示  
Belt tension indicator applied to mid centre distance.

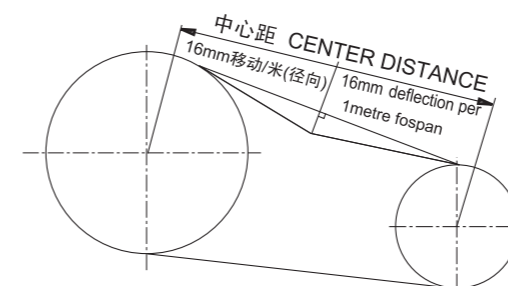

## 安装与维护

### A) 皮带传动安装

1. 拆除风机轴端的保护并检查有无缺口和毛刺;
2. 检查风机和电机轴之间的平行度;
3. 中心距控制在  $0.7(d1+d2) < a < 2(d1+d2)$ , 前向风机皮带速度应控制在 10~15m/s; 后向风机皮带速度应控制在 25~35m/s;
4. 将皮带轮套在轴上滑进去, 不要敲击, 以免损伤轴承;
5. 用一根直尺把风机和电机上的带轮对齐并紧固;
6. 把皮带套进皮带轮, 不要撬、挤压, 以免损伤皮带;
7. 调整张紧度直至皮带看起来松紧适度, 风机运行几分钟后, 再调整皮带至合适的张紧度;

## Installation and Maintenance

### A) V-belt drive Installation

1. Remove the protective coating from the ends of the fan shaft and ensure that the shaft ends are free of nick and burrs.
2. Check fan and motor shafts for alignment.
3. The center distance must be controlled as  $0.7(d1+d2) < a < 2(d1+d2)$ . The belt speed of forward curve fan should be more than 10m/s, but less than 15m/s, ( $10 < v < 15m/s$ ). The belt speed of backward curve fan should be more 25m/s, but less than 35m/s ( $25 < v < 35m/s$ ).
4. Slide sheaves on to the shafts, Do not hammer the sheaves on to the shafts with force as this may result in bearing damage.
5. Align fan and motor sheaves with a straight-edge, and tighten the sheaves.
6. Place belts over the sheaves with care. Do not bend or squeeze the belts, or it might get damaged.

### C) 轴承润滑

风机使用带座轴承，可通过加油嘴注入润滑油。润滑油有效期取决于油脂类型、轴承的转速和工作温度。判断是否加油的最好办法是当加新油时观察清除下来的旧油脂，可延长换油脂的间隔，如果清除下来的油脂比新的黑得多表明油脂已氧化，应缩短换油脂的间隔。

### C) Bearing Lubrication

The fan bearings are filled with lubricant when they ship from the factory, so the bearings do not require any additional grease to be supplied before starting the fan. The fans that are equipped with pillow block bearing are provided with lubrication fittings, and these fittings allow for additional lubrication to the supplied to the bearings at regular intervals. The allowable period of time between lubrication of these bearings depends upon the operating speeds and temperatures of the bearing as well as on the type of lubrication. It is recommended to inspect the condition of the grease that is discharged from the bearings when new grease is added. If the discharged grease looks similar to the new grease, then a longer period of time between lubrications is possible. If the discharged grease is much darker than the new grease, this indicates that the grease is being oxidized and more frequent lubrications of the bearings are required.

### 说明

- 1). 订货时须注明风机型号、转速、风量、风压、出风口方向和旋转方向。若需配套皮带、皮带轮、电机、安装底座等配件及其它特殊要求可在订货时提出。
- 2). 在安装前应对风机各部件进行检查，对叶轮、主轴和轴承等主要机件应重点细致检查，如有损伤应修复后再安装使用。
- 3). 检查机壳和其它壳体内部，不应有掉入、遗留的工具和杂物。
- 4). 风机正式运转前，需检查电机的转向是否符合风机转向的要求。
- 5). 风管与出风口之间应采用软连接，接头不得拉紧。
- 6). 风机安装后用手或杠杆拨动叶轮，检查是否过紧或碰撞现象，确认无这些现象时方可进行试转。
- 7). 风机配用电机功率是指在特定工况下，风机内功率加上机械损失与电机容量安全系数而言，并非出风口全敞开时所需的功率。为防止电机超功率运行而烧毁，严禁风机出风口或进风口不接管路或未加外界任何阻力进行空运转。
- 8). 风机在无较大腐蚀性气体、不含酸（碱）性和尘颗粒物小于  $150\text{mg}/\text{m}^3$  的气体、温度小于  $85^\circ\text{C}$  大于  $-20^\circ\text{C}$  的气体环境下使用，风机在运输装卸过程中应小心轻放，防止碰撞挤压。

### Instructions

- 1) When placing the order, it is necessary to state the type of fan, speed, air volume, air pressure, discharge direction, rotation direction, type of electric motor and its specifications.
- 2) Prior to installation, the fan should be carefully inspected. Special care should be taken in checking the shaft, impeller and bearings. If there is an indication of any damage, the damaged parts should be repaired or replaced before the fan is installed or commissioned.
- 3) The inside of the scroll and casing need to be checked to make sure that there are no foreign objects inside the housing, such as tools or loose parts.
- 4) The rotational directions of the motor and impeller should be checked to ensure that they are in compliance with the specification and purchase orders.
- 5) A flexible connector should be used between the fan out let flange and its mating ductwork. The flex connector should not be over-stretched.
- 6) Following the installation, the impeller should be turned by hand or with the use of a wrench to make sure that it turns freely without colliding with other parts of the fan. Once all this is done, the fan can be commissioned normally.
- 7) The rated motor power as calculated herein might not be sufficient to drive the fan with an unrestricted discharge flow. Operating the fan with an unrestricted discharge outlet will result in flow rate that exceeds the specified fan capabilities. Such operation will quickly burn the motor and damage the fan. Great care must be taken in operating the fan to make sure that the maximum rated flows, as provided on the performance charts in this catalog, are not exceeded.
- 8) The fan is limited for use in areas where air substances are non-corrosive, non-toxic and non-erosive and where dust particles are less than  $150\text{mg}/\text{m}^3$  with a temperature between  $-20^\circ\text{C}$  and  $85^\circ\text{C}$ . Special care should be taken during transportation, load and unload.

### 技术参数

Wheel diameter	叶轮直径	D = 200 mm	Fan weight	风机质量	m = 10 kg
Moment of inertia	转动惯量	J = 0.006 kg·m <sup>2</sup>	Speed limit	极限转速	n <sub>max</sub> = 4900 r/min

### Technical Data

### 性能曲线

经认证的性能是B类安装：自由入口，管道出口。功率额定值(kW)不包括传输损失。各项性能额定值不包括附属物(附件)的影响。所示A加权声音性能额定值已按AMCA International标准301计算。所示值为安装类型B：自由入口，管道出口的声功率级（入口L<sub>wA</sub>）。

### Performance Curve

Performance certified is for installation type B: free inlet, ducted outlet. Power rating (kW) does not include transmission losses. Performance ratings do not include the effects of appurtenances (accessories). The A-weighted sound ratings shown have been calculated per AMCA International Standard 301. Values shown are for inlet L<sub>wA</sub> sound power levels for installation type B: free inlet, ducted outlet.

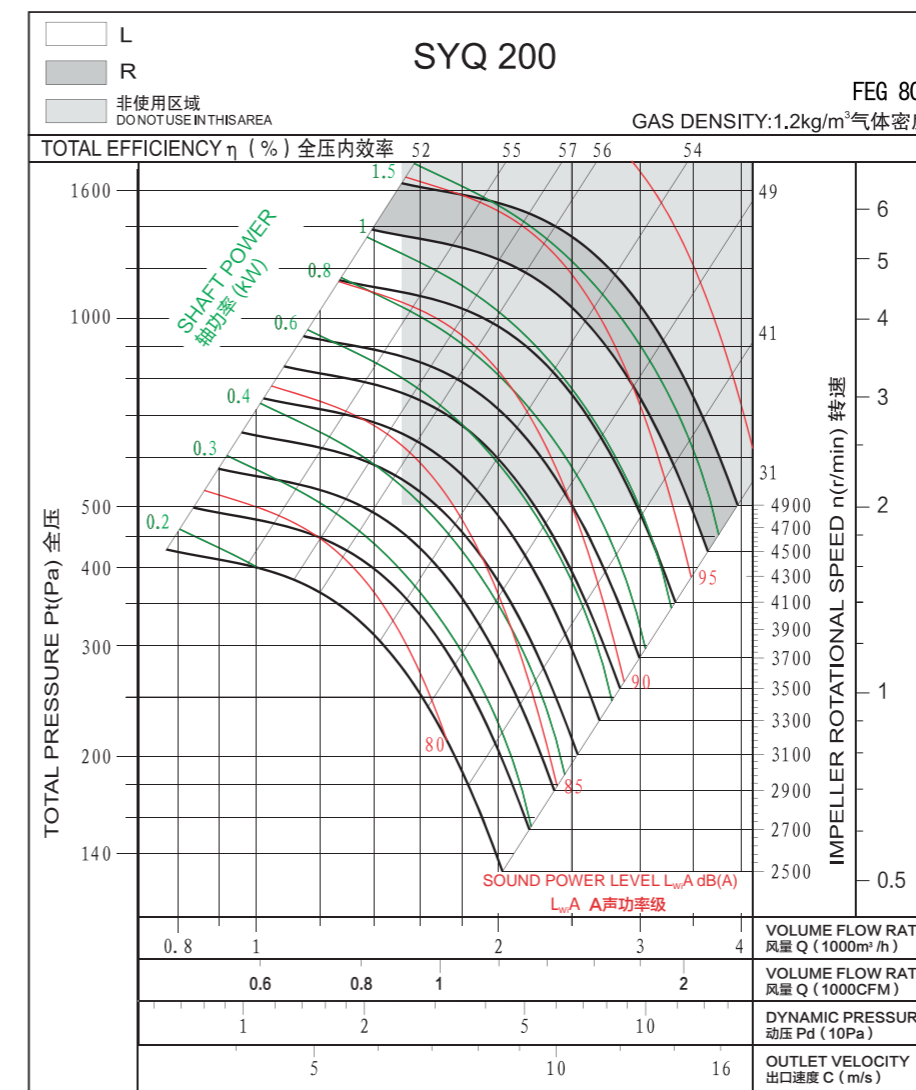

Measured in installation B according to AMCA Standard 210:

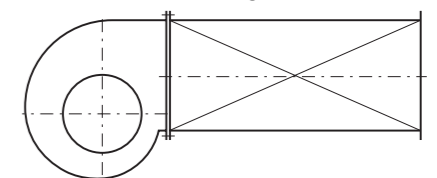



## 技术参数

## Technical Data

Wheel diameter 叶轮直径	D = 225 mm	Fan weight 风机质量	m = 12 kg
Moment of inertia 转动惯量	J = 0.012kg · m <sup>2</sup>	Speed limit 极限转速	n <sub>max</sub> = 4600r/min

## 技术参数

## Technical Data

Wheel diameter 叶轮直径	D = 250 mm	Fan weight 风机质量	m = 18 kg
Moment of inertia 转动惯量	J = 0.044kg · m <sup>2</sup>	Speed limit 极限转速	n <sub>max</sub> = 4100 r/min

## 性能曲线

## Performance Curve

经认证的性能是B类安装：自由入口，管道出口。功率额定值(kW)不包括传输损失。各项性能额定值不包括附属物(附件)的影响。所示A加权声音性能额定值已按AMCA International标准301计算。所示值为安装类型B：自由入口，管道出口的声功率级（入口L<sub>wA</sub>）。

Performance certified is for installation type B: free inlet, ducted outlet. Power rating (kW) does not include transmission losses. Performance ratings do not include the effects of appurtenances (accessories). The A-weighted sound ratings shown have been calculated per AMCA International Standard 301. Values shown are for inlet L<sub>wA</sub> sound power levels for installation type B: free inlet, ducted outlet.

## 性能曲线

## Performance Curve

经认证的性能是B类安装：自由入口，管道出口。功率额定值(kW)不包括传输损失。各项性能额定值不包括附属物(附件)的影响。所示A加权声音性能额定值已按AMCA International标准301计算。所示值为安装类型B：自由入口，管道出口的声功率级（入口L<sub>wA</sub>）。

Performance certified is for installation type B: free inlet, ducted outlet. Power rating (kW) does not include transmission losses. Performance ratings do not include the effects of appurtenances (accessories). The A-weighted sound ratings shown have been calculated per AMCA International Standard 301. Values shown are for inlet L<sub>wA</sub> sound power levels for installation type B: free inlet, ducted outlet.

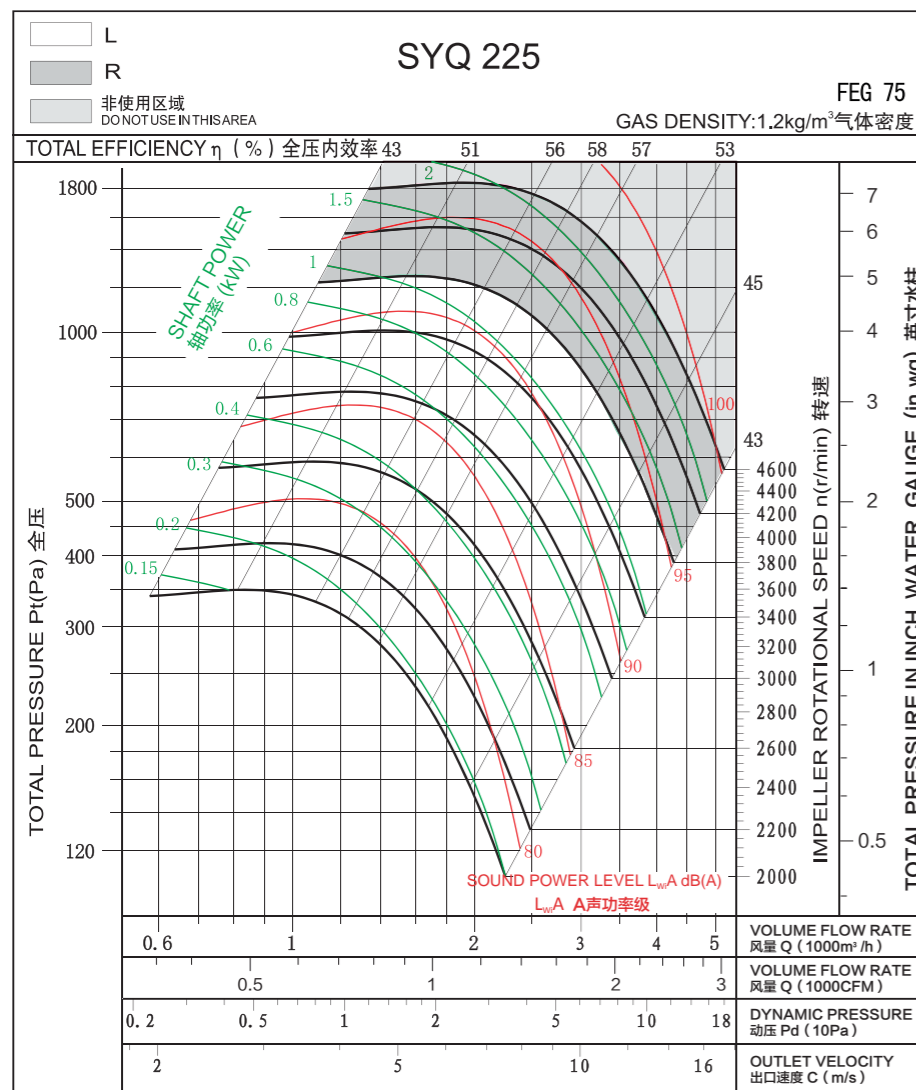

Measured in installation B according to AMCA Standard 210:

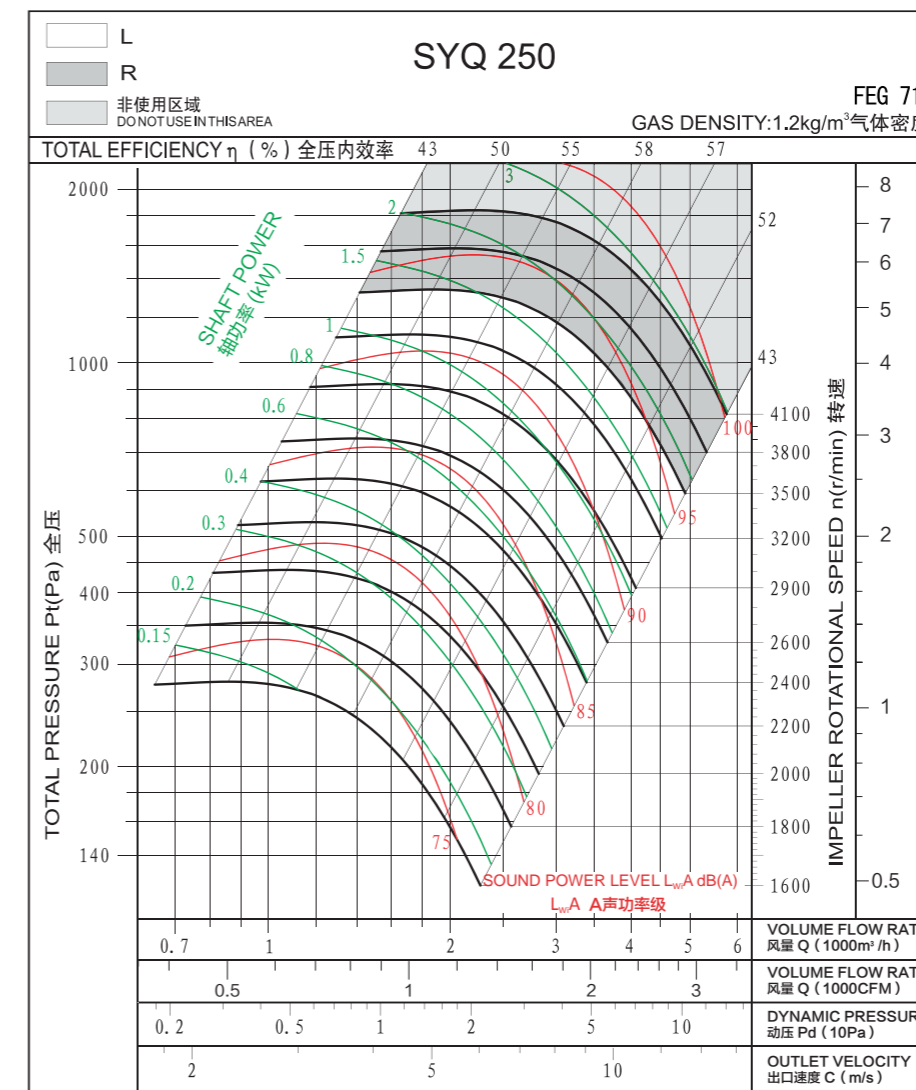
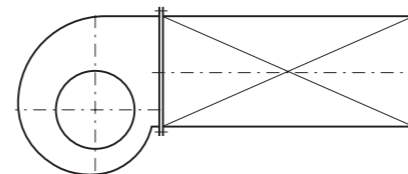

Measured in installation B according to AMCA Standard 210:

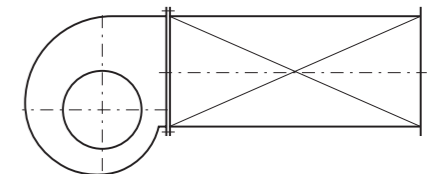

## 技术参数

## Technical Data

Wheel diameter 叶轮直径	D = 280 mm	Fan weight 风机质量	m = 32 kg
Moment of inertia 转动惯量	J = 0.069kg · m <sup>2</sup>	Speed limit 极限转速	n <sub>max</sub> = 4500r/min

## 技术参数

## Technical Data

Wheel diameter 叶轮直径	D = 315mm	Fan weight 风机质量	m = 42.6 kg
Moment of inertia 转动惯量	J = 0.11kg · m <sup>2</sup>	Speed limit 极限转速	n <sub>max</sub> = 4000 r/min

## 性能曲线

## Performance Curve

经认证的性能是B类安装：自由入口，管道出口。功率额定值(kW)不包括传输损失。各项性能额定值不包括附属物(附件)的影响。所示A加权声音性能额定值已按AMCA International标准301计算。所示值为安装类型B：自由入口，管道出口的声功率级（入口L<sub>wA</sub>）。

Performance certified is for installation type B: free inlet, ducted outlet. Power rating (kW) does not include transmission losses. Performance ratings do not include the effects of appurtenances (accessories). The A-weighted sound ratings shown have been calculated per AMCA International Standard 301. Values shown are for inlet L<sub>wA</sub> sound power levels for installation type B: free inlet, ducted outlet.

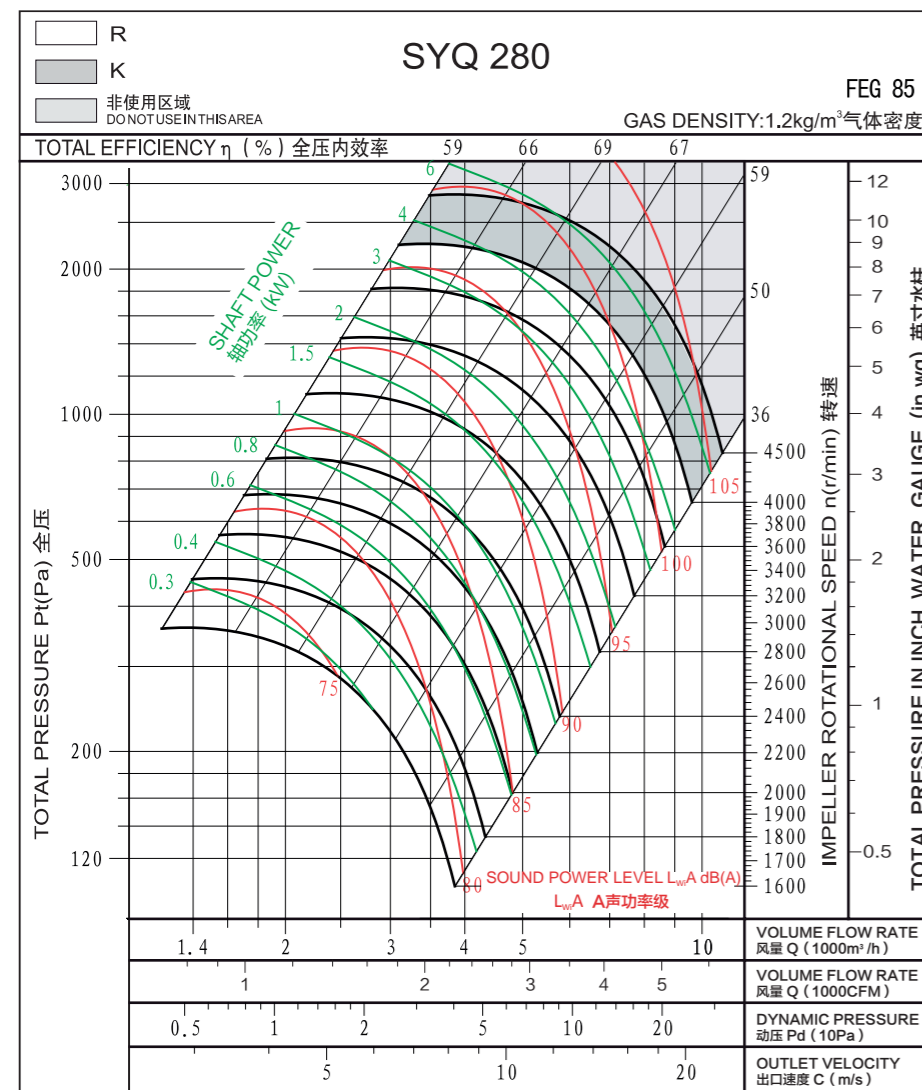

Measured in installation B according to AMCA Standard 210:

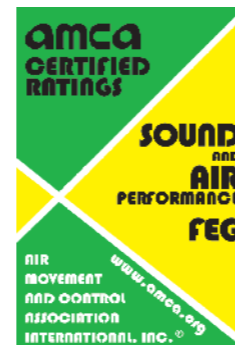
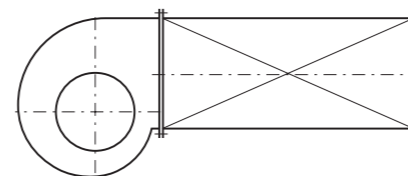

## 性能曲线

## Performance Curve

经认证的性能是B类安装：自由入口，管道出口。功率额定值(kW)不包括传输损失。各项性能额定值不包括附属物(附件)的影响。所示A加权声音性能额定值已按AMCA International标准301计算。所示值为安装类型B：自由入口，管道出口的声功率级（入口L<sub>wA</sub>）。

Performance certified is for installation type B: free inlet, ducted outlet. Power rating (kW) does not include transmission losses. Performance ratings do not include the effects of appurtenances (accessories). The A-weighted sound ratings shown have been calculated per AMCA International Standard 301. Values shown are for inlet L<sub>wA</sub> sound power levels for installation type B: free inlet, ducted outlet.

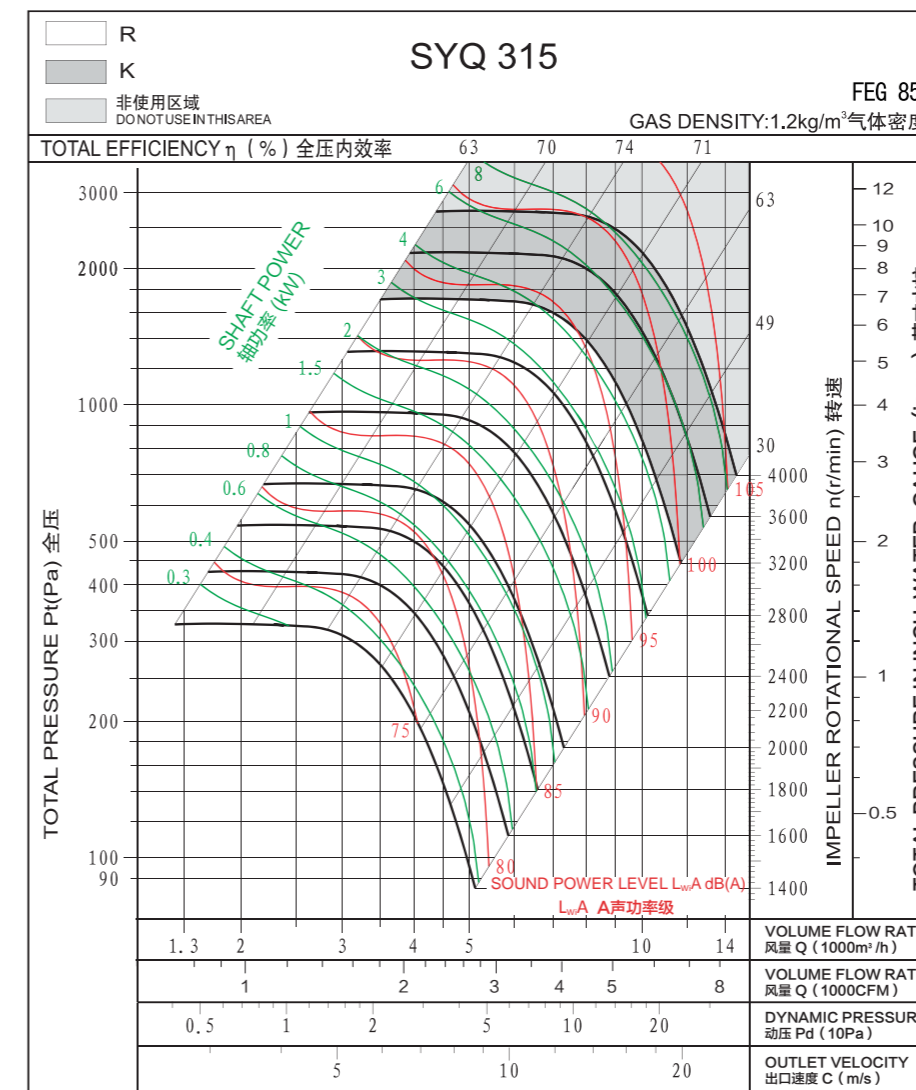

Measured in installation B according to AMCA Standard 210:

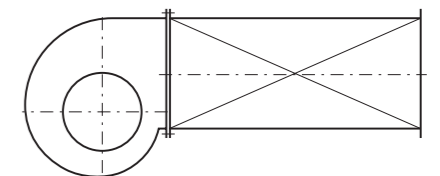

## 技术参数

## Technical Data

Wheel diameter 叶轮直径	D = 355 mm	Fan weight 风机质量	m = 54.7kg
Moment of inertia 转动惯量	J = 0.2kg · m <sup>2</sup>	Speed limit 极限转速	n <sub>max</sub> = 3800r/min

## 技术参数

## Technical Data

Wheel diameter 叶轮直径	D = 400mm	Fan weight 风机质量	m = 63.6 kg
Moment of inertia 转动惯量	J = 0.34 kg · m <sup>2</sup>	Speed limit 极限转速	n <sub>max</sub> = 3200 r/min

## 性能曲线

## Performance Curve

经认证的性能是B类安装：自由入口，管道出口。功率额定值(kW)不包括传输损失。各项性能额定值不包括附属物(附件)的影响。所示A加权声音性能额定值已按AMCA International标准301计算。所示值为安装类型B：自由入口，管道出口的声功率级（入口L<sub>wA</sub>）。

Performance certified is for installation type B: free inlet, ducted outlet. Power rating (kW) does not include transmission losses. Performance ratings do not include the effects of appurtenances (accessories). The A-weighted sound ratings shown have been calculated per AMCA International Standard 301. Values shown are for inlet L<sub>wA</sub> sound power levels for installation type B: free inlet, ducted outlet.

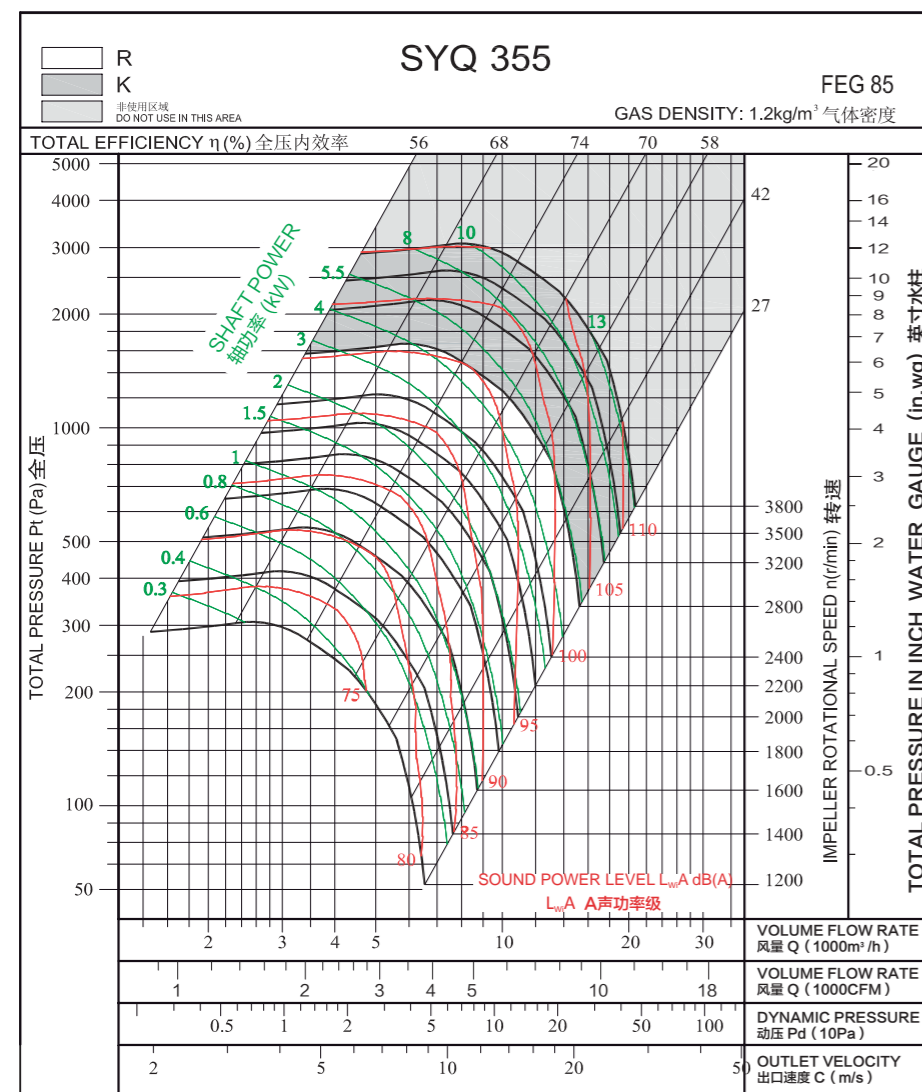

Measured in installation B according to AMCA Standard 210:

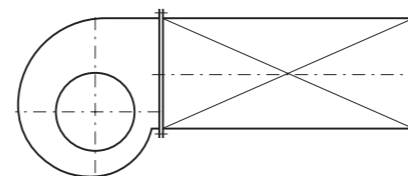

## 性能曲线

## Performance Curve

经认证的性能是B类安装：自由入口，管道出口。功率额定值(kW)不包括传输损失。各项性能额定值不包括附属物(附件)的影响。所示A加权声音性能额定值已按AMCA International标准301计算。所示值为安装类型B：自由入口，管道出口的声功率级（入口L<sub>wA</sub>）。

Performance certified is for installation type B: free inlet, ducted outlet. Power rating (kW) does not include transmission losses. Performance ratings do not include the effects of appurtenances (accessories). The A-weighted sound ratings shown have been calculated per AMCA International Standard 301. Values shown are for inlet L<sub>wA</sub> sound power levels for installation type B: free inlet, ducted outlet.

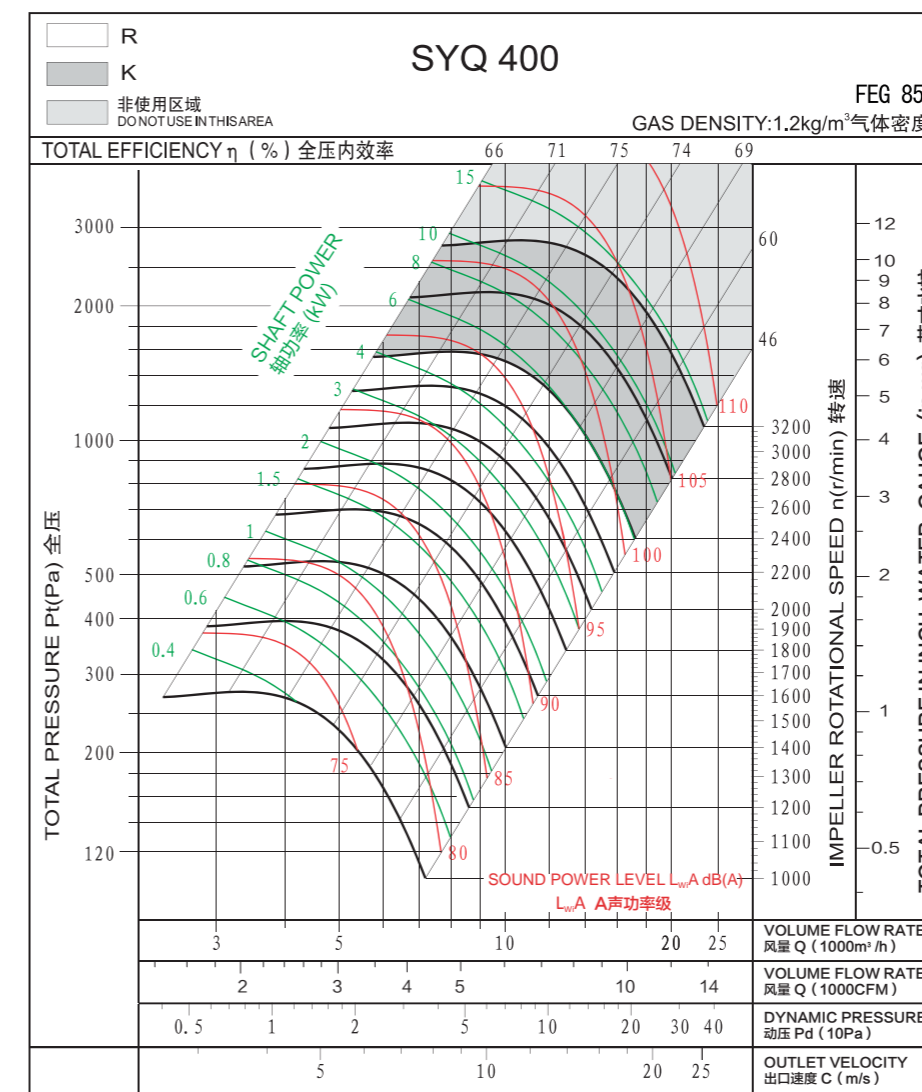

Measured in installation B according to AMCA Standard 210:

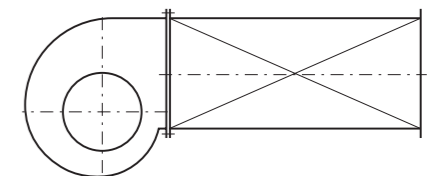



## 技术参数

## Technical Data

Wheel diameter 叶轮直径	D = 450 mm	Fan weight 风机质量	m = 82.5 kg
Moment of inertia 转动惯量	J = 0.51kg · m <sup>2</sup>	Speed limit 极限转速	n <sub>max</sub> = 2800 r/min

## 技术参数

## Technical Data

Wheel diameter 叶轮直径	D = 500 mm	Fan weight 风机质量	m = 104.2 kg
Moment of inertia 转动惯量	J = 0.88 kg · m <sup>2</sup>	Speed limit 极限转速	n <sub>max</sub> = 2800 r/min

## 性能曲线

## Performance Curve

经认证的性能是B类安装：自由入口，管道出口。功率额定值(kW)不包括传输损失。各项性能额定值不包括附属物(附件)的影响。所示A加权声音性能额定值已按AMCA International标准301计算。所示值为安装类型B：自由入口，管道出口的声功率级（入口L<sub>w,A</sub>）。

Performance certified is for installation type B: free inlet, ducted outlet. Power rating (kW) does not include transmission losses. Performance ratings do not include the effects of appurtenances (accessories). The A-weighted sound ratings shown have been calculated per AMCA International Standard 301. Values shown are for inlet L<sub>w,A</sub> sound power levels for installation type B: free inlet, ducted outlet.

## 性能曲线

## Performance Curve

经认证的性能是B类安装：自由入口，管道出口。功率额定值(kW)不包括传输损失。各项性能额定值不包括附属物(附件)的影响。所示A加权声音性能额定值已按AMCA International标准301计算。所示值为安装类型B：自由入口，管道出口的声功率级（入口L<sub>w,A</sub>）。

Performance certified is for installation type B: free inlet, ducted outlet. Power rating (kW) does not include transmission losses. Performance ratings do not include the effects of appurtenances (accessories). The A-weighted sound ratings shown have been calculated per AMCA International Standard 301. Values shown are for inlet L<sub>w,A</sub> sound power levels for installation type B: free inlet, ducted outlet.

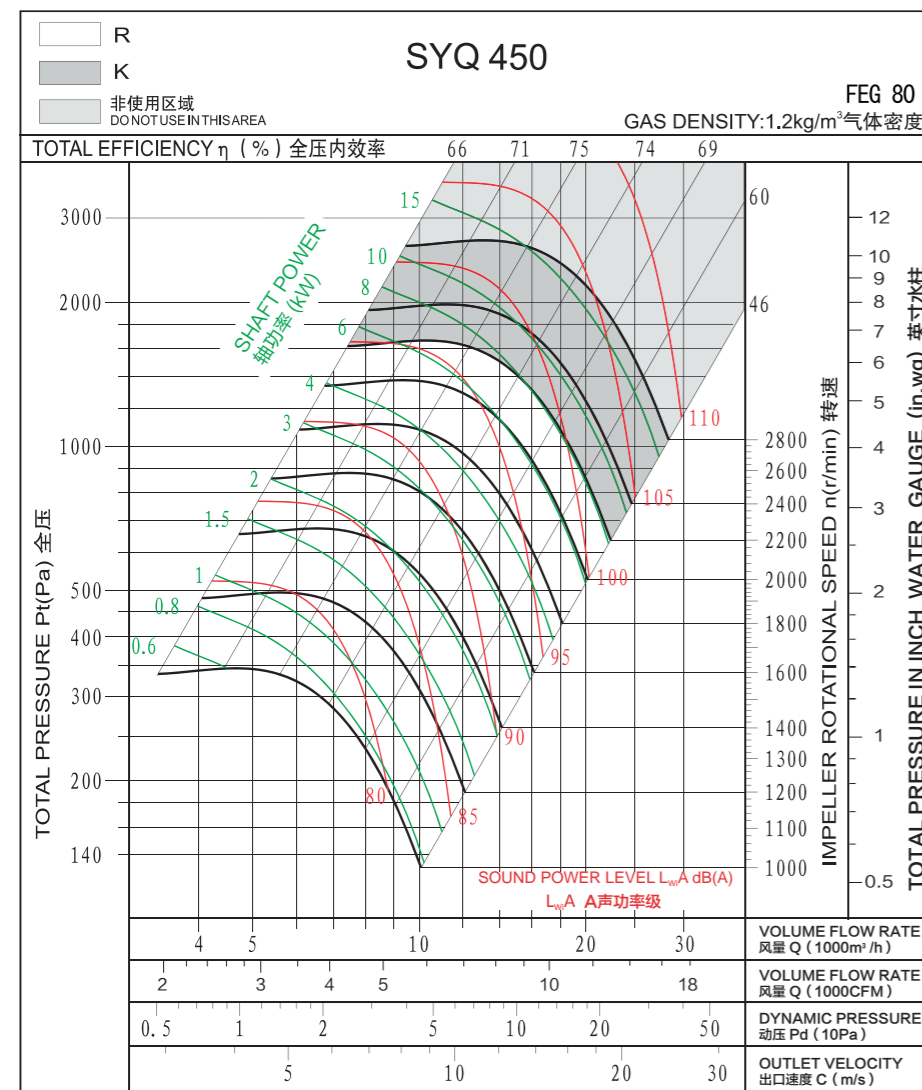

Measured in installation B according to AMCA Standard 210:

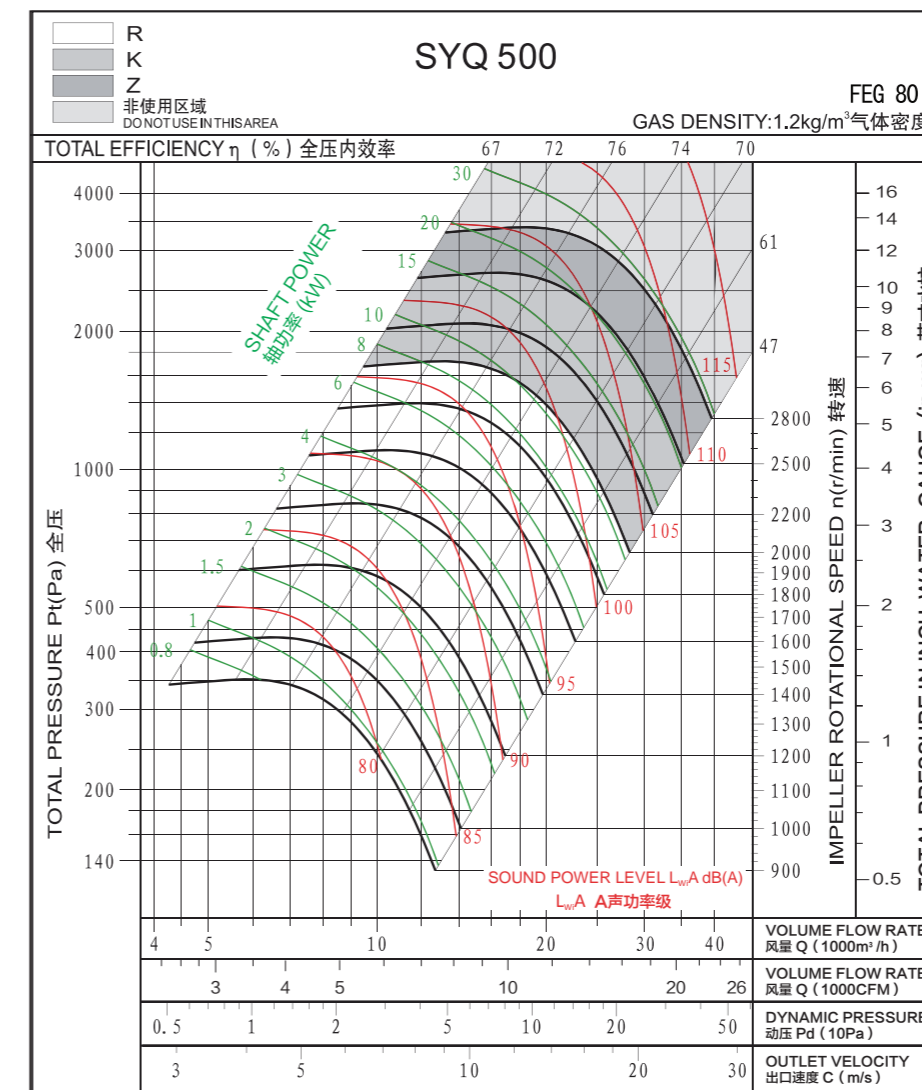
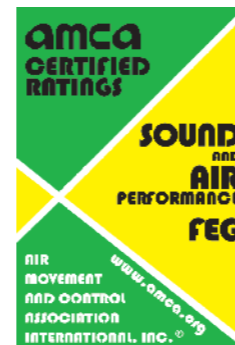
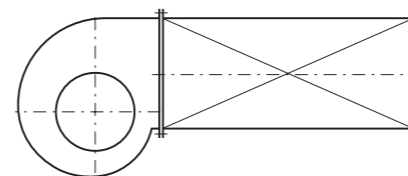

Measured in installation B according to AMCA Standard 210:

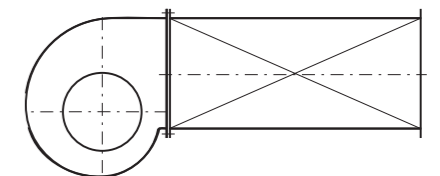

## 技术参数

## Technical Data

Wheel diameter 叶轮直径	D = 560 mm	Fan weight 风机质量	m = 171 kg
Moment of inertia 转动惯量	J = 1.42 kg · m <sup>2</sup>	Speed limit 极限转速	n <sub>max</sub> = 2600 r/min

## 技术参数

## Technical Data

Wheel diameter 叶轮直径	D = 630 mm	Fan weight 风机质量	m = 197 kg
Moment of inertia 转动惯量	J = 2.32kg · m <sup>2</sup>	Speed limit 极限转速	n <sub>max</sub> = 2200 r/min

## 性能曲线

## Performance Curve

经认证的性能是B类安装：自由入口，管道出口。功率额定值(kW)不包括传输损失。各项性能额定值不包括附属物(附件)的影响。所示A加权声音性能额定值已按AMCA International标准301计算。所示值为安装类型B：自由入口，管道出口的声功率级（入口L<sub>wA</sub>）。

Performance certified is for installation type B: free inlet, ducted outlet. Power rating (kW) does not include transmission losses. Performance ratings do not include the effects of appurtenances (accessories). The A-weighted sound ratings shown have been calculated per AMCA International Standard 301. Values shown are for inlet L<sub>wA</sub> sound power levels for installation type B: free inlet, ducted outlet.

## 性能曲线

## Performance Curve

经认证的性能是B类安装：自由入口，管道出口。功率额定值(kW)不包括传输损失。各项性能额定值不包括附属物(附件)的影响。所示A加权声音性能额定值已按AMCA International标准301计算。所示值为安装类型B：自由入口，管道出口的声功率级（入口L<sub>wA</sub>）。

Performance certified is for installation type B: free inlet, ducted outlet. Power rating (kW) does not include transmission losses. Performance ratings do not include the effects of appurtenances (accessories). The A-weighted sound ratings shown have been calculated per AMCA International Standard 301. Values shown are for inlet L<sub>wA</sub> sound power levels for installation type B: free inlet, ducted outlet.

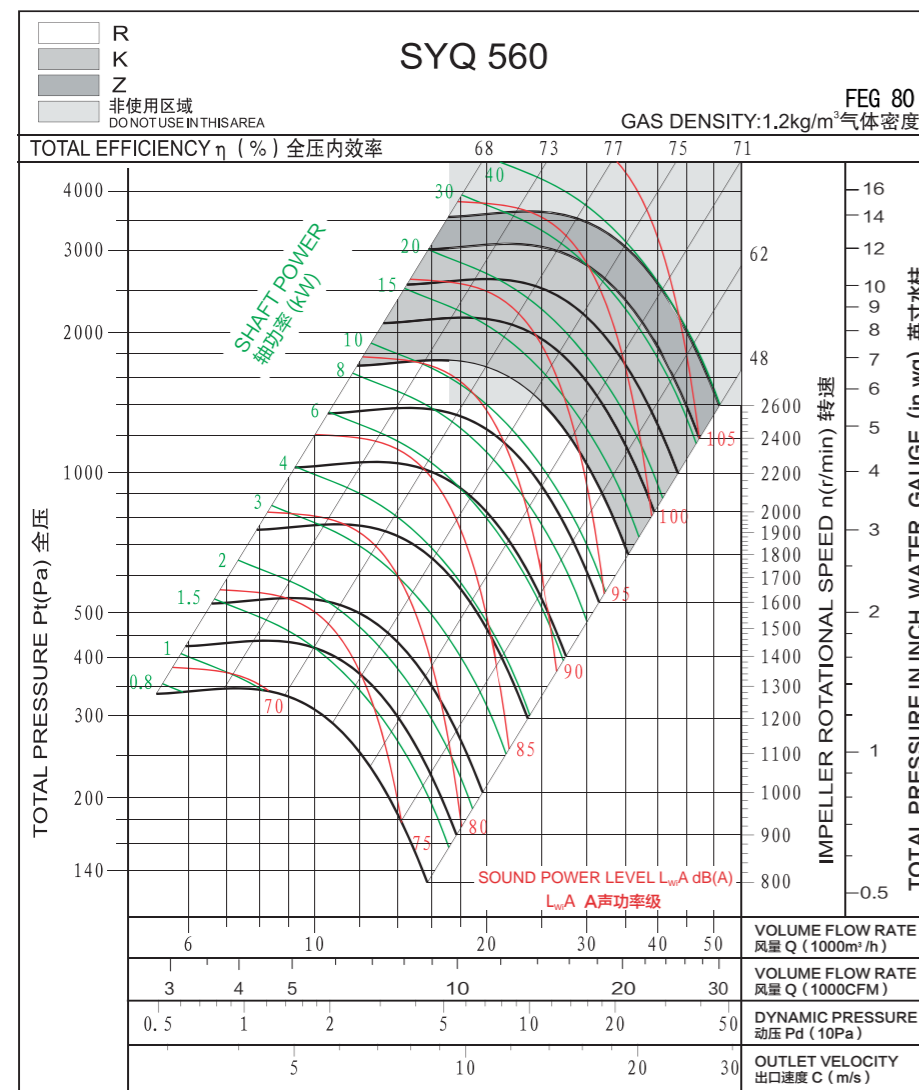

Measured in installation B according to AMCA Standard 210:

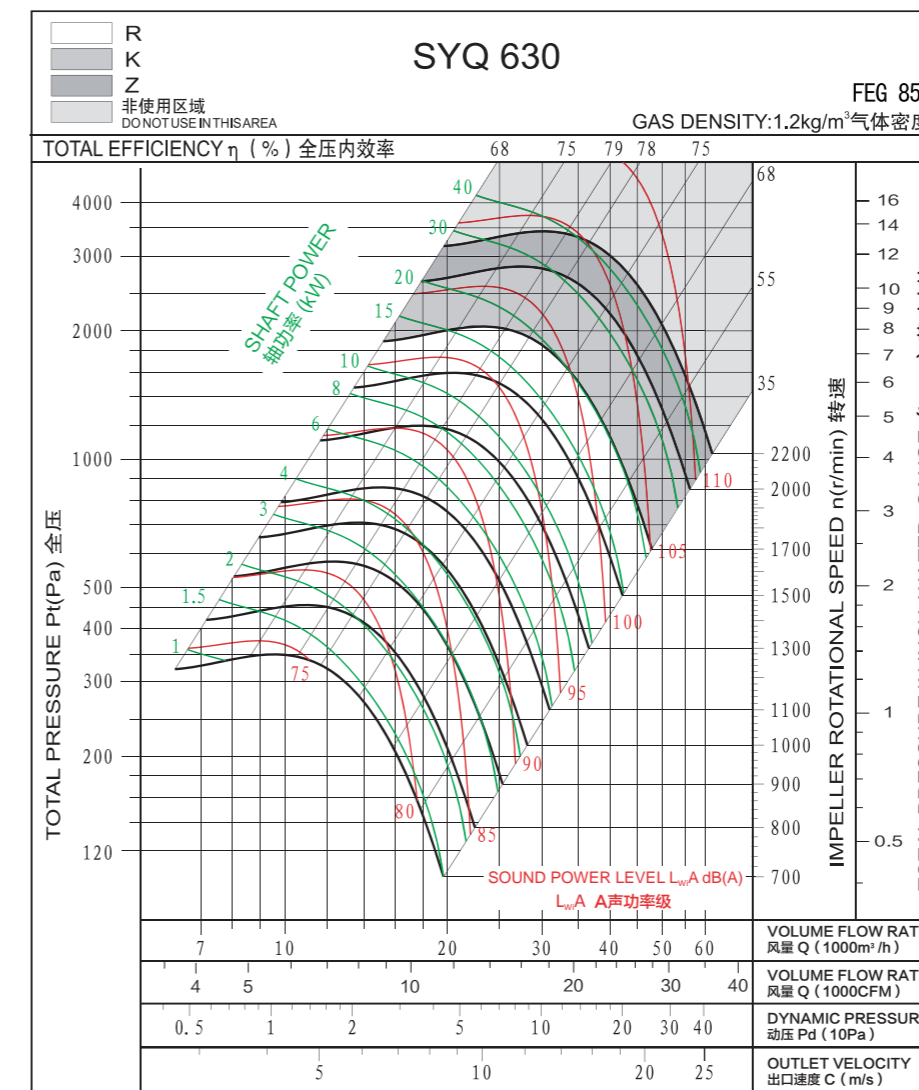
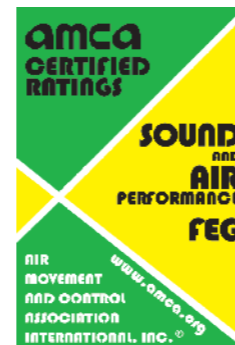
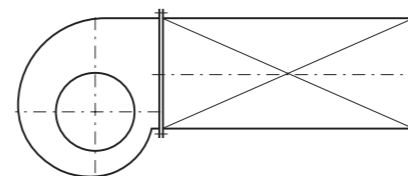

Measured in installation B according to AMCA Standard 210:

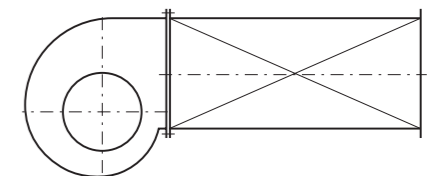

### 技术参数

### Technical Data

Wheel diameter 叶轮直径	D = 710mm	Fan weight 风机质量	m = 271 kg
Moment of inertia 转动惯量	J = 4.75kg · m <sup>2</sup>	Speed limit 极限转速	n <sub>max</sub> = 2000r/min

### 技术参数

### Technical Data

Wheel diameter 叶轮直径	D = 800mm	Fan weight 风机质量	m = 300 kg
Moment of inertia 转动惯量	J = 9.25kg · m <sup>2</sup>	Speed limit 极限转速	n <sub>max</sub> = 1600r/min

### 性能曲线

### Performance Curve

经认证的性能是B类安装：自由入口，管道出口。功率额定值(kW)不包括传输损失。各项性能额定值不包括附属物(附件)的影响。所示A加权声音性能额定值已按AMCA International标准301计算。所示值为安装类型B：自由入口，管道出口的声功率级（入口L<sub>WA</sub>）。

Performance certified is for installation type B: free inlet, ducted outlet. Power rating (kW) does not include transmission losses. Performance ratings do not include the effects of appurtenances (accessories). The A-weighted sound ratings shown have been calculated per AMCA International Standard 301. Values shown are for inlet L<sub>WA</sub> sound power levels for installation type B: free inlet, ducted outlet.

### 性能曲线

### Performance Curve

经认证的性能是B类安装：自由入口，管道出口。功率额定值(kW)不包括传输损失。各项性能额定值不包括附属物(附件)的影响。所示A加权声音性能额定值已按AMCA International标准301计算。所示值为安装类型B：自由入口，管道出口的声功率级（入口L<sub>WA</sub>）。

Performance certified is for installation type B: free inlet, ducted outlet. Power rating (kW) does not include transmission losses. Performance ratings do not include the effects of appurtenances (accessories). The A-weighted sound ratings shown have been calculated per AMCA International Standard 301. Values shown are for inlet L<sub>WA</sub> sound power levels for installation type B: free inlet, ducted outlet.

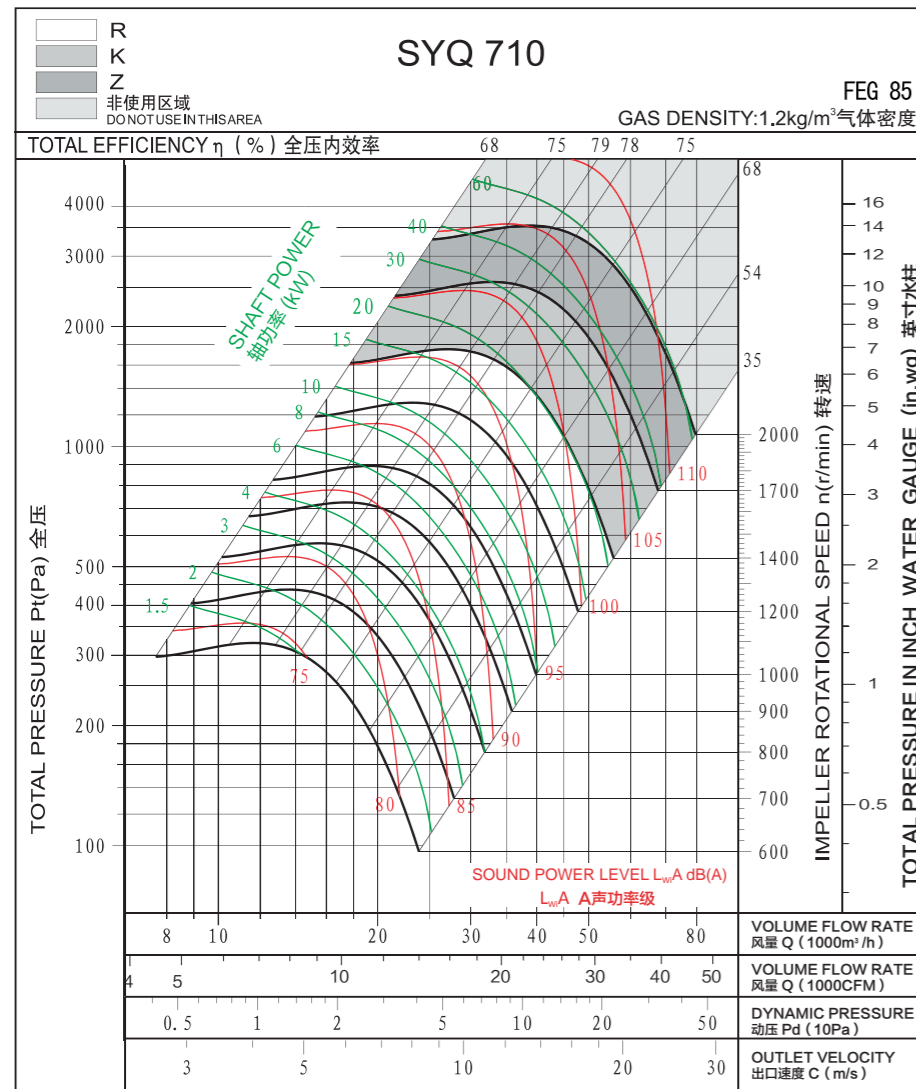

Measured in installation B according to AMCA Standard 210:

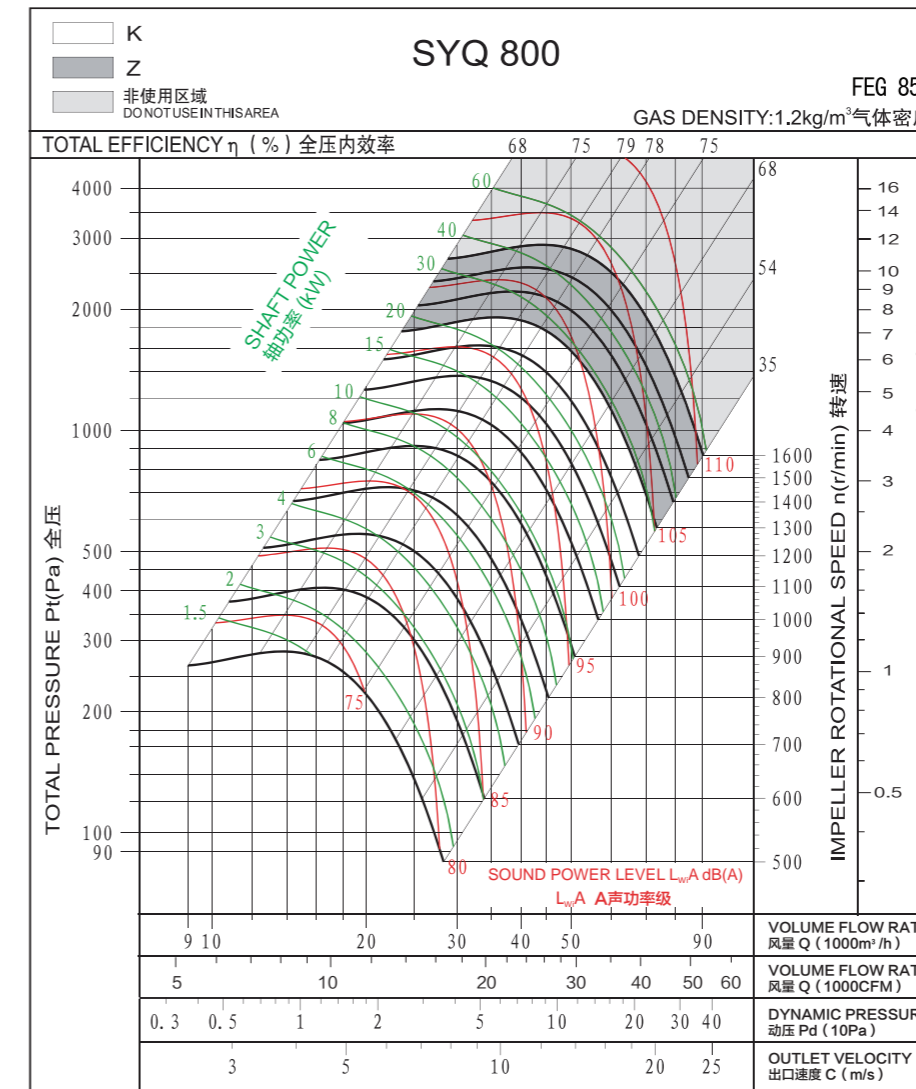
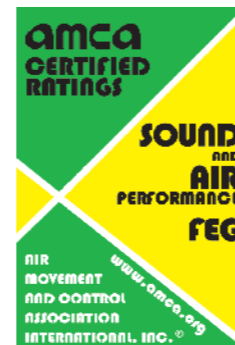
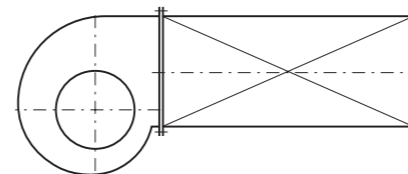

Measured in installation B according to AMCA Standard 210:

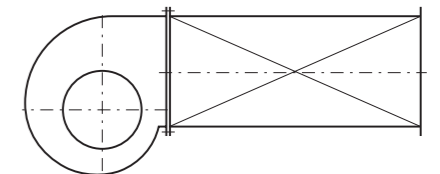



## 技术参数

## Technical Data

Wheel diameter 叶轮直径	D = 900mm	Fan weight 风机质量	m = 530 kg
Moment of inertia 转动惯量	J = 13.8kg · m <sup>2</sup>	Speed limit 极限转速	n <sub>max</sub> = 1300r/min

## 技术参数

## Technical Data

Wheel diameter 叶轮直径	D = 1000 mm	Fan weight 风机质量	m = 530kg
Moment of inertia 转动惯量	J = 24.8kg · m <sup>2</sup>	Speed limit 极限转速	n <sub>max</sub> = 1300 r/min

## 性能曲线

## Performance Curve

经认证的性能是B类安装：自由入口，管道出口。功率额定值(kW)不包括传输损失。各项性能额定值不包括附属物(附件)的影响。所示A加权声音性能额定值已按AMCA International标准301计算。所示值为安装类型B：自由入口，管道出口的声功率级（入口L<sub>wA</sub>）。

Performance certified is for installation type B: free inlet, ducted outlet. Power rating (kW) does not include transmission losses. Performance ratings do not include the effects of appurtenances (accessories). The A-weighted sound ratings shown have been calculated per AMCA International Standard 301. Values shown are for inlet L<sub>wA</sub> sound power levels for installation type B: free inlet, ducted outlet.

## 性能曲线

## Performance Curve

经认证的性能是B类安装：自由入口，管道出口。功率额定值(kW)不包括传输损失。各项性能额定值不包括附属物(附件)的影响。所示A加权声音性能额定值已按AMCA International标准301计算。所示值为安装类型B：自由入口，管道出口的声功率级（入口L<sub>wA</sub>）。

Performance certified is for installation type B: free inlet, ducted outlet. Power rating (kW) does not include transmission losses. Performance ratings do not include the effects of appurtenances (accessories). The A-weighted sound ratings shown have been calculated per AMCA International Standard 301. Values shown are for inlet L<sub>wA</sub> sound power levels for installation type B: free inlet, ducted outlet.

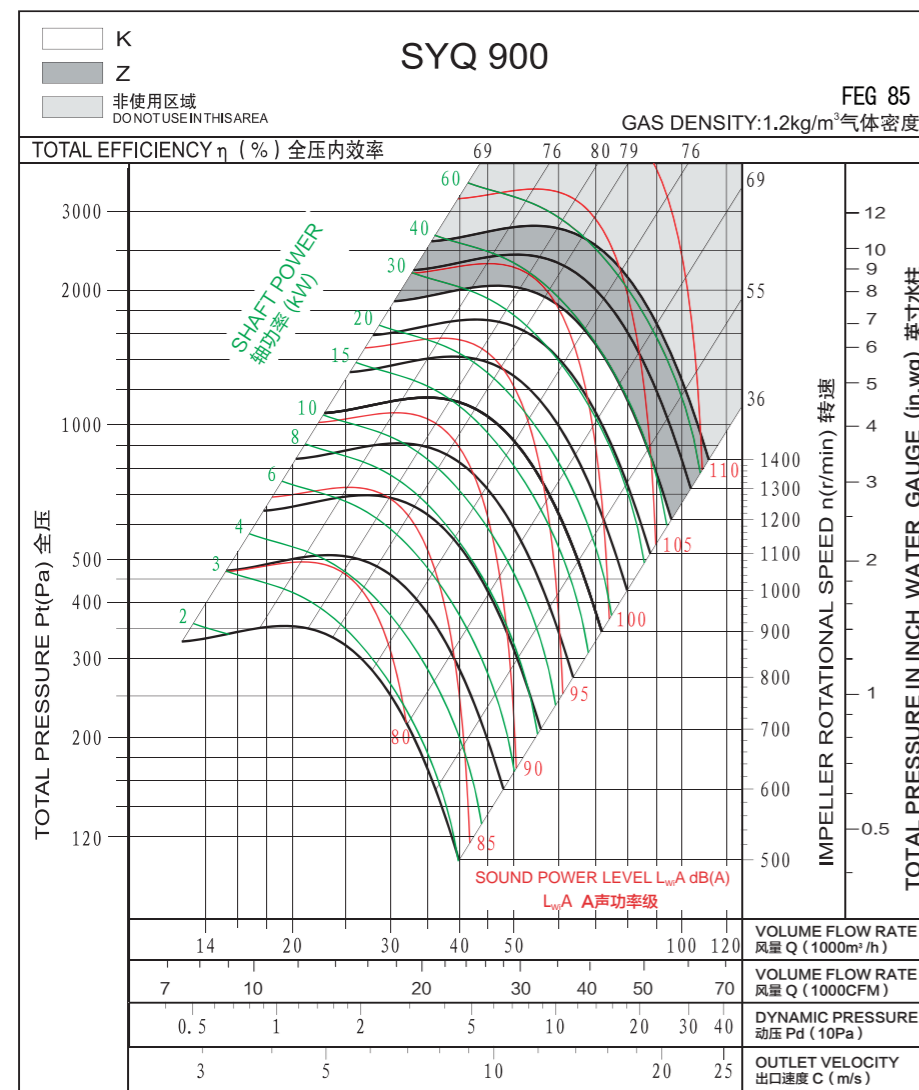

Measured in installation B according to AMCA Standard 210:

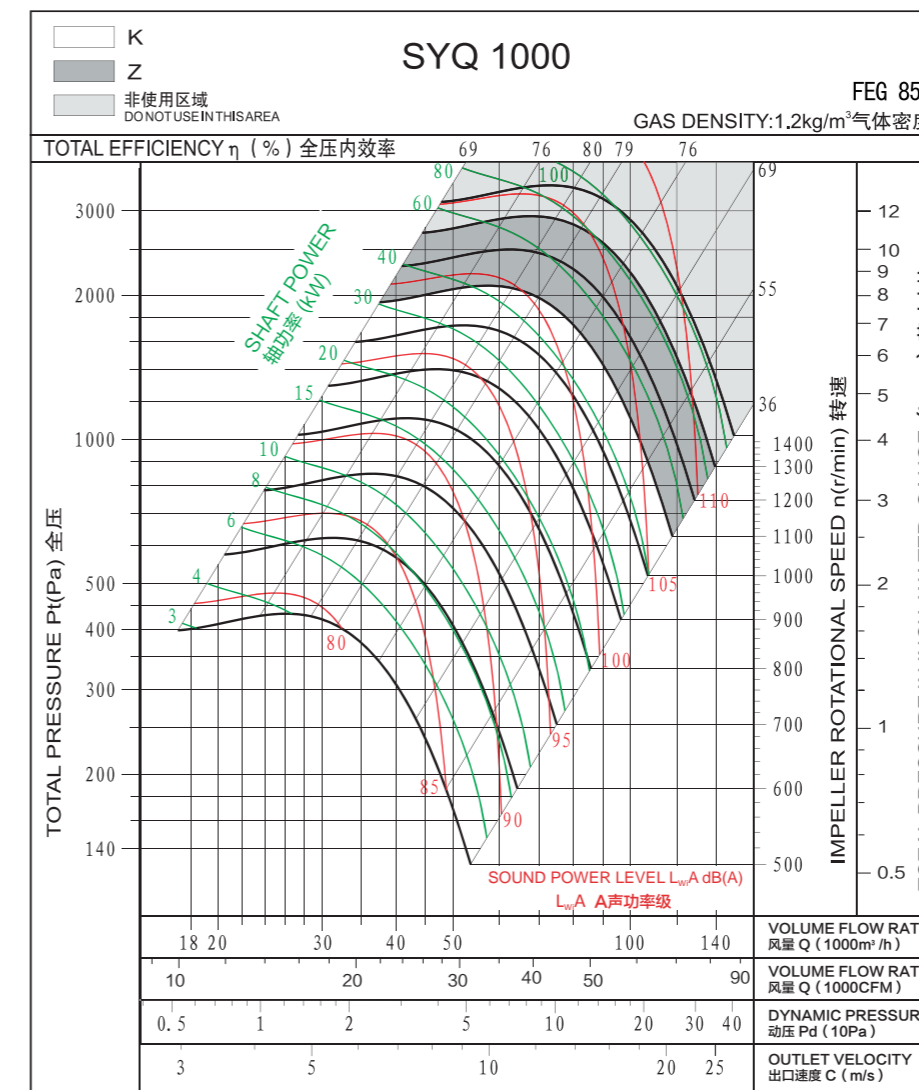
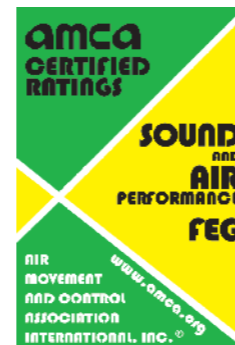
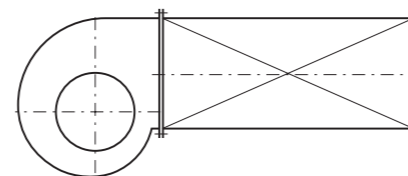

Measured in installation B according to AMCA Standard 210:

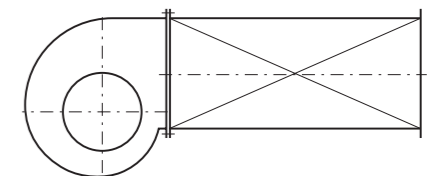

出口法兰

Outlet Flange



图 3 (Fig 3) 单位: mm

Dim	200	225	250	280	315	355	400	450	500	560	630	710	800	900	1000
A	256	288	322	361	404	453	507	569	638	715	801	898	1007	1130	1267
B	296	328	362	417	460	509	563	625	694	771	857	954	1063	1186	1323
C	138	154	171	196	217	242	-	-	-	-	-	-	-	-	-
D				-	-	-	-	-	-	-	-	200	250	300	350
E		-	-	-	-	-	200	200	250	250	300	400	500	600	700
F				-	-	-	169	200	209	248	266	264	269	280	299

SYQ-R

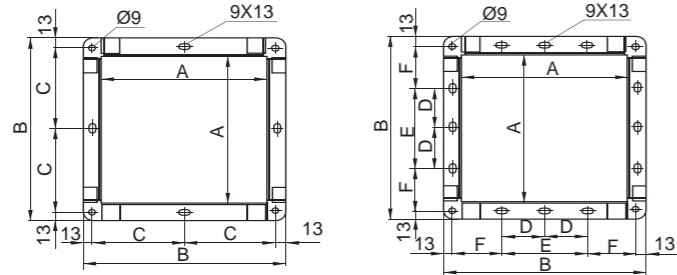
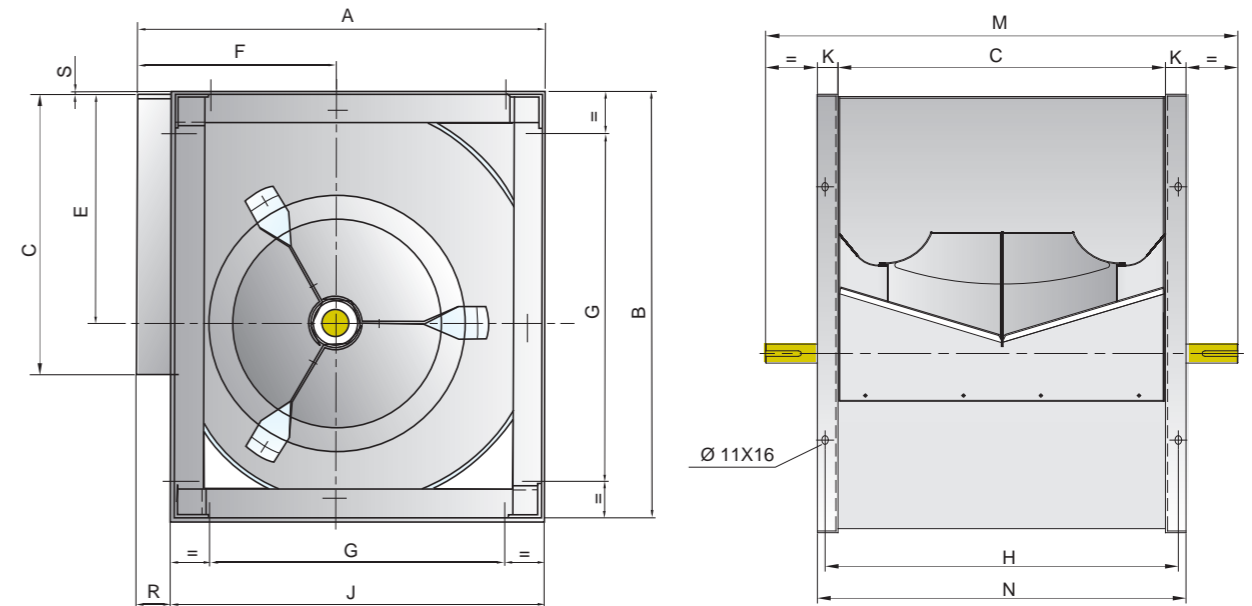

SYQ-L

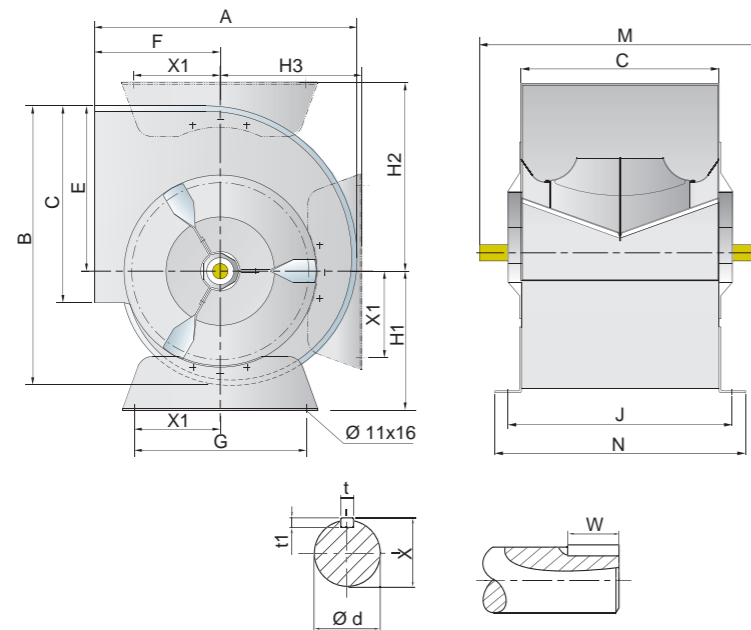

单位: mm

Dim	A	B	C	E	F	G	J	M	N	X1	H1	H2	H3	t	t1	X	W	phi d
200	342	364	256	215	164	224	281	420	306	112	181	245	184	6	6	22.5	40	20
225	380	408	288	243	180	224	313	460	338	112	197	274	204	6	6	22.5	50	20
250	417	454	322	270	195	224	347	490	372	112	212	299	227	6	6	22.5	55	20

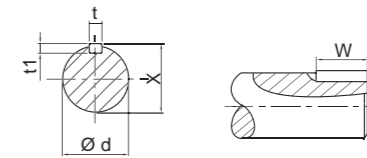

单位: mm

Dim	A	B	C	E	F	G	H	J	K	M	N	R	S	t	t1	X	W	phi d
200	343	370	256	215	164	224	281	306	25	420	306	37	4	6	6	22.5	40	20
225	383	415	288	243	180	224	313	348	25	460	338	35	3	6	6	22.5	50	20
250	419	461	322	270	195	224	347	384	25	490	372	35	4	6	6	22.5	55	20

SYQ-R

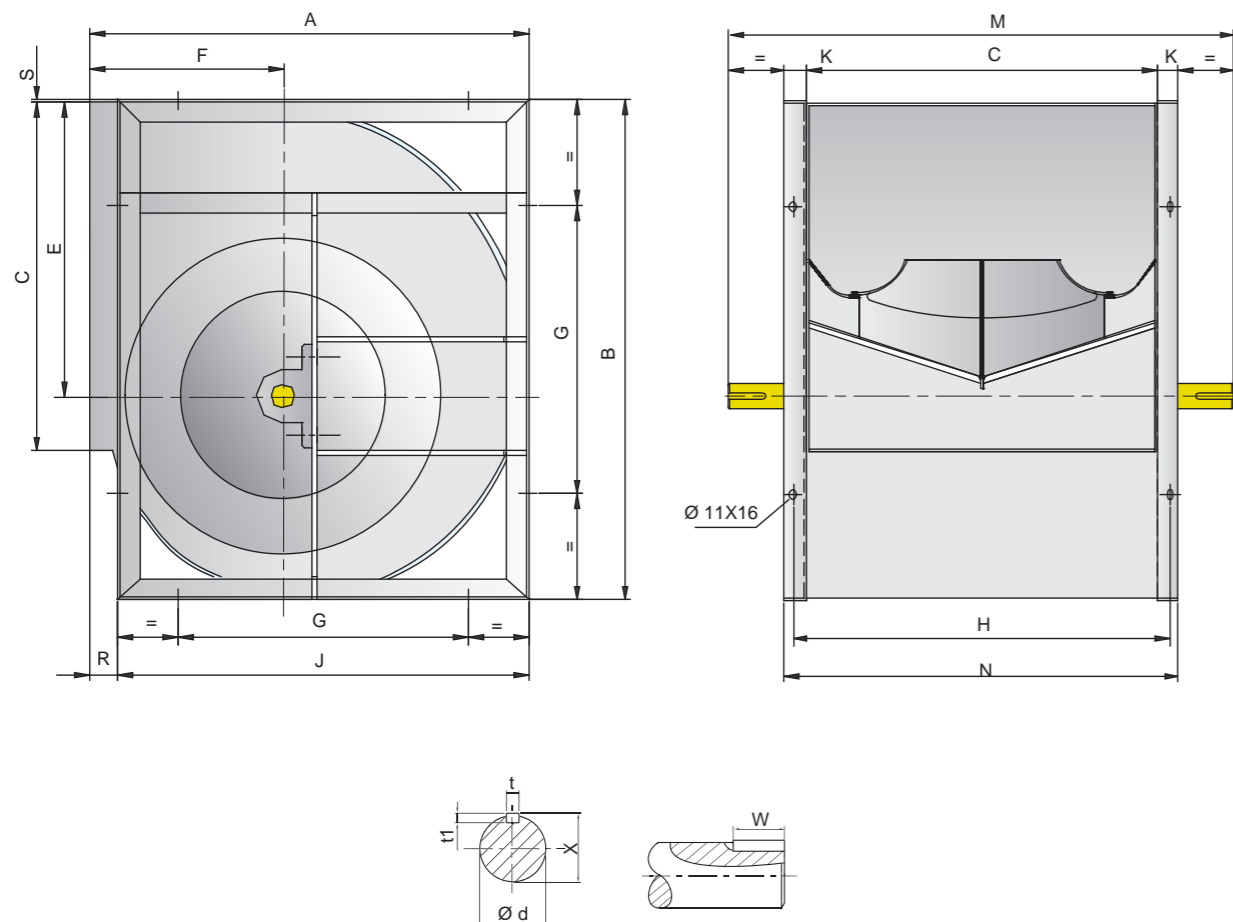

单位: mm

Model Dim	A	B	C	E	F	G	H	J	K	M	N	R	S	t	t1	W	X	φd	LxV
280	466	518	361	302	215	280	391	432	30	575	421	34	5	8	7	50	28	25	13x18
315	518	578	404	340	236	280	434	480	30	640	464	38	3	8	7	60	28	25	13x18
355	578	655	453	383	261	355	493	548	40	700	533	30	6	8	7	60	33	30	13x18
400	651	736	507	432	290	355	547	613	40	760	587	38	4.5	8	7	60	33	30	13x18
450	726	827	569	486	322	530	609	681	40	845	649	45	5	10	8	70	38	35	13x18
500	800	918	638	538	352	530	678	750	40	915	718	50	5	10	8	70	38	35	13x18
560	893	1030	715	602	390	530	765	845	50	1000	815	48	8	12	8	70	43	40	13x18
630	999	1157	801	679	434	530	851	946	50	1090	901	53	7	14	9	70	48.5	45	13x18
710	1121	1303	898	765	485	630	948	1058	50	1255	998	63	7	14	9	90	53.5	50	17x22

SYQ-K(Z)

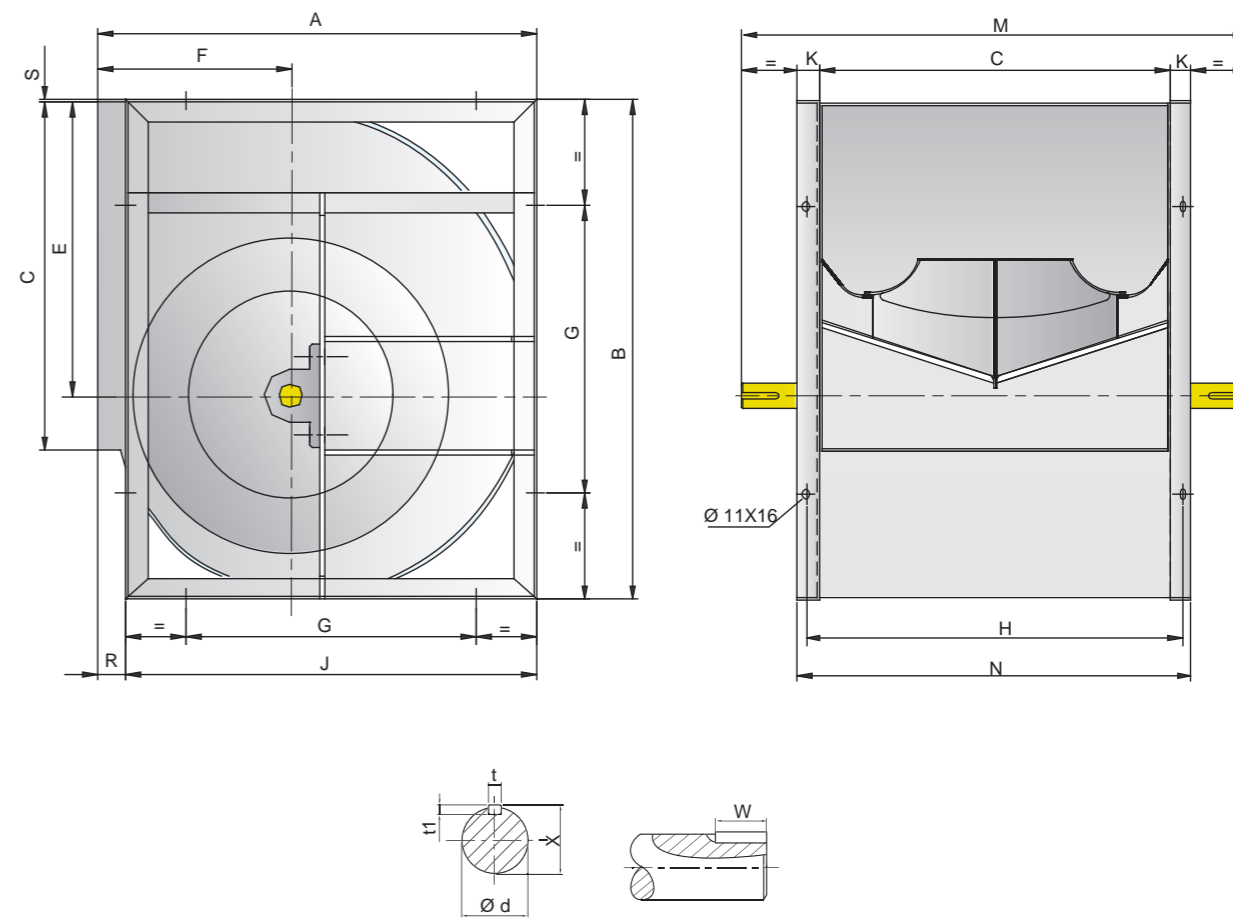

单位: mm

Model Dim	A	B	C	E	F	G	H	J	K	M	N	R	S	t	t1	W	X	φd	LxV
280	466	518	361	302	215	280	391	432	30	600	421	34	5	8	7	60	33	30	13x18
315	518	578	404	340	236	280	434	480	30	665	464	38	3	8	7	70	33	30	13x18
355	578	655	453	383	261	355	493	548	40	725	533	30	6	10	8	70	38	35	13x18
400	651	736	507	432	290	355	547	613	40	790	587	38	4.5	10	8	70	38	35	13x18
450	726	827	569	486	322	530	609	681	40	890	649	45	4.5	12	8	90	43	40	13x18
500	800	918	638	538	352	530	678	750	40	960	718	50	5	12	8	90	43	40	13x18
560	893	1030	715	603	390	530	765	845	50	1070	815	48	8	14	9	90	53.5	50	13x18
630	899	1157	801	679	434	530	851	946	50	1155	901	53	7	14	9	90	53.5	50	13x18
710	1121	1303	898	765	485	630	948	1058	50	1293	998	63	7	18	11	90	64	60	17x22
800	1250	1468	1007	862	535	710	1057	1181	50	1450	1107	69	7	18	11	90	64	60	17x22
900	1408	1648	1130	971	604	800	1180	1319	60	1570	1250	89	7	18	11	100	69	65	17x22
1000	1541	1810	1267	1066	657	900	1317	1462	60	1700	1387	79	9	18	11	100	69	65	17x22



**SYQ-R(K)2**

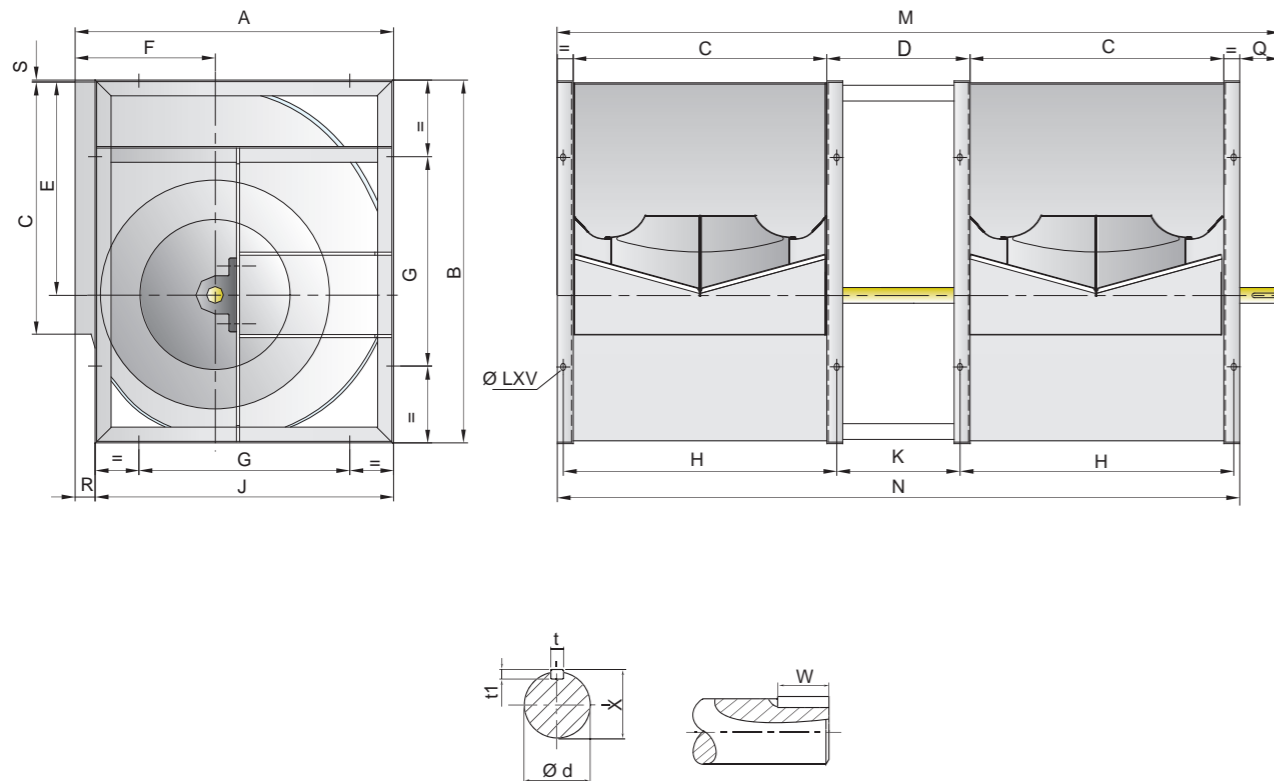

**SYQ-R2**

单位: mm

Dim	Model	A	B	C	D	E	F	G	H	J	K	M	N	Q	R	S	t	t1	W	X	$\varnothing d$	LxV
280		466	518	361	280	302	214	280	391	432	250	1165	1062	103	34	5	8	7	60	28	25	13x18
315		518	578	404	315	340	236	280	434	480	285	1286	1183	103	38	3	8	7	60	33	30	13x18
355		578	654	453	355	383	260	355	493	548	315	1442	1340	101	30	6	10	8	60	38	35	13x18
400		65	736	507	400	432	290	355	547	612	360	1610	1494	116	38	4.5	12	8	60	43	40	13x18
450		726	827	569	450	486	322	530	609	681	410	1782	1668	114	45	5	12	8	70	43	40	13x18
500		800	918	638	500	538	352	530	678	750	460	1165	1062	103	50	5	14	9	70	48.5	45	13x18

**SYQ-K2**

单位: mm

Dim	Model	A	B	C	D	E	F	G	H	J	K	M	N	Q	R	S	t	t1	W	X	$\varnothing d$	LxV
355		578	654	453	355	383	260	355	493	548	315	1442	1341	101	30	6	12	8	70	43	40	13x18
400		650	736	507	400	432	290	355	547	612	360	1610	1494	116	38	4.5	14	9	70	48.5	45	13x18
450		726	827	569	450	486	322	530	609	681	410	1795	1668	127	45	5	14	9	90	48.5	45	13x18
500		800	918	638	500	538	352	530	678	750	460	1977	1856	121	50	5	14	9	90	53.5	50	13x18
560		893	1030	715	560	602	390	530	765	845	510	2218	2090	128	48	8	14	9	90	53.5	50	13x18

**SYQ-L**

		0°		90°		180°	
左旋 LG Left Hand							
右旋 RD Right Hand							
型号 Model	电机 机座型号 Motor Frame Size	A	B	A	B	A	B
200	56	730	420	730	348	730	396
	63	730	420	730	348	730	396
	71	730	420	730	348	730	396
	80	730	420	730	348	730	396
225	63	760	460	760	384	760	440
	71	760	460	760	384	760	440
	80	760	460	760	384	760	440
250	90	760	460	760	384	760	440
	63	820	490	820	422	820	482
	71	820	490	820	422	820	482
	80	820	490	820	422	820	482
	90	820	490	820	422	820	482

**SYQ-R**

		0°		90°		180°	
左旋 LG Left Hand							
右旋 RD Right Hand							
型号 Model	电机 机座型号 Motor Frame Size	A	B	A	B	A	B
200	56	730	420	730	348	730	396
	63	730	420	730	348	730	396
	71	730	420	730	348	730	396
	80	730	420	730	348	730	396
225	63	760	460	760	384	760	440
	71	760	460	760	384	760	440
	80	760	460	760	384	760	440
250	90	760	460	760	384	760	440
	63	820	490	820	422	820	482
	71	820	490	820	422	820	482
	80	820	490	820	422	820	482
	90	820	490	820	422	820	482

SYQ-R(K)

		0°				90°				180°			
左旋 LG Left Hand													
右旋 RD Right Hand													
型号 Model	电机 机座型号 Motor Frame Size	A	B		C	A	B		C	A	B		C
			R型	K型			R型	K型			R型	K型	
280	71	940	575	600	568	940	575	600	516	940	575	600	568
	80	940	575	600	568	940	575	600	516	940	575	600	568
	90	940	575	600	568	940	575	600	516	940	575	600	568
	100	940	575	600	568	940	575	600	516	940	575	600	568
	112	940	575	600	568	940	575	600	516	940	575	600	568
	132	940	575	600	568	940	575	600	516	940	575	600	568
315	71	1040	640	665	628	1040	640	665	568	1040	640	665	628
	80	1040	640	665	628	1040	640	665	568	1040	640	665	628
	90	1040	640	665	628	1040	640	665	568	1040	640	665	628
	100	1040	640	665	628	1040	640	665	568	1040	640	665	628
	112	1040	640	665	628	1040	640	665	568	1040	640	665	628
	132	1040	640	665	628	1040	640	665	568	1040	640	665	628
355	80	1110	700	725	705	1110	700	725	628	1110	700	725	705
	90	1110	700	725	705	1110	700	725	628	1110	700	725	705
	100	1110	700	725	705	1110	700	725	628	1110	700	725	705
	112	1110	700	725	705	1110	700	725	628	1110	700	725	705
	132	1110	700	725	705	1110	700	725	628	1110	700	725	705
	160	1110	700	725	705	1110	700	725	628	1110	700	725	705
400	180	1250	700	725	705	1250	700	725	628	1250	700	725	705
	90	1250	760	790	786	1250	760	790	701	1250	760	790	786
	100	1250	760	790	786	1250	760	790	701	1250	760	790	786
	112	1250	760	790	786	1250	760	790	701	1250	760	790	786
	132	1250	760	790	786	1250	760	790	701	1250	760	790	786
	160	1250	760	790	786	1250	760	790	701	1250	760	790	786
450	90	1340	845	890	877	1340	845	890	776	1340	845	890	877
	100	1340	845	890	877	1340	845	890	776	1340	845	890	877
	112	1340	845	890	877	1340	845	890	776	1340	845	890	877
	132	1340	845	890	877	1340	845	890	776	1340	845	890	877
	160	1340	845	890	877	1340	845	890	776	1340	845	890	877
	180	1340	845	890	877	1340	845	890	776	1340	845	890	877
500	200	1340	845	890	877	1340	845	890	776	1340	845	890	877
	90	1420	915	960	981	1420	915	960	863	1420	915	960	981
	100	1420	915	960	981	1420	915	960	863	1420	915	960	981
	112	1420	915	960	981	1420	915	960	863	1420	915	960	981
	132	1420	915	960	981	1420	915	960	863	1420	915	960	981
	160	1420	915	960	981	1420	915	960	863	1420	915	960	981

SYQ-R(K)

		0°				90°				180°			
左旋 LG Left Hand													
右旋 RD Right Hand													
型号 Model	电机 机座型号 Motor Frame Size	A	B		C	A	B		C	A	B		C
			R型	K型			R型	K型			R型	K型	
560	90	1580	1000	1070	1093	1580	1000	1070	956	1580	1000	1070	1093
	100	1580	1000	1070	1093	1580	1000	1070	956	1580	1000	1070	1093
	112	1580	1000	1070	1093	1580	1000	1070	956	1580	1000	1070	1093
	132	1580	1000	1070	1093	1580	1000	1070	956	1580	1000	1070	1093
	160	1580	1000	1070	1093	1580	1000	1070	956	1580	1000	1070	1093
	180	1580	1000	1070	1093	1580	1000	1070	956	1580	1000	1070	1093
	200	1580	1000	1070	1093	1580	1000	1070	956	1580	1000	1070	1093
630	100	1770	1090	1155	1220	1770	1090	1155	1062	1770	1090	1155	1220
	112	1770	1090	1155	1220	1770	1090	1155	1062	1770	1090	1155	1220
	132	1770	1090	1155	1220	1770	1090	1155	1062	1770	1090	1155	1220
	160	1770	1090	1155	1220	1770	1090	1155	1062	1770	1090	1155	1220
	180	1770	1090	1155	1220	1770	1090	1155	1062	1770	1090	1155	1220
	200	1770	1090	1155	1220	1770	1090	1155	1062	1770	1090	1155	1220
710	112	1950	1255	1290	1366	1950	1255	1290	1184	1950	1255	1290	1366
	132	1950	1255	1290	1366	1950	1255	1290	1184	1950	1255	1290	1366
	160	1950	1255	1290	1366	1950	1255	1290	1184	1950	1255	1290	1366
	200	1950	1255	1290	1366	1950	1255	1290	1184	1950	1255	1290	1366
	225	1950	1255	1290	1366	1950	1255	1290	1184	1950	1255	1290	1366
	250	1950	1255	1290	1366	1950	1255	1290	1184	1950	1255	1290	1366
800	132	2130	\	1450	1548	2130	\	1450	1330	2130	\	1450	1548
	160	2130	\	1450	1548	2130	\	1450	1330	2130	\	1450	1548
	180	2130	\	1450	1548	2130	\	1450	1330	2130	\	1450	1548
	200	2130	\	1450	1548	2130	\	1450	1330	2130	\	1450	1548
	225	2130	\	1450	1548	2130	\	1450	1330	2130	\	1450	1548
	250	2130	\	1450	1548	2130	\	1450	1330	2130	\	1450	1548
900	132	2450	\	1570	1748	2450	\	1570	1508	2450	\	1570	1748
	160	2450	\	1570	1748	2450	\	1570	1508	2450	\	1570	1748
	180	2450	\	1570	1748	2450	\	1570	1508	2450	\	1570	1748
	200	2450	\	1570	1748	2450	\	1570	1508	2450	\	1570	1748
	225	2450	\	1570	1748	2450	\	1570	1508	2450	\	1570	1748
	250	2450	\	1570	1748	2450	\	1570	1508	2450	\	1570	1748
1000	280	2450	\	1570	1748	2450	\	1570	1508	2450	\	1570	1748
	132	2650	\	1700	1910	2650	\	1700	1641	2650	\	1700	1910
	160	2650	\	1700	1910	2650	\	1700	1641	2650	\	1700	1910
	180	2650	\	1700	1910	2650	\	1700	1641	2650	\	1700	1910
	200	2650	\	1700	1910	2650	\	1700	1641	2650	\	1700	1910
	225	2650	\	1700	1910	2650	\	1700	1641	2650	\	1700	1910

**SYQ-R(K)**

		0°			90°			180°		
左旋 LG Left Hand										
右旋 RD Right Hand										
型号 Model	电机 机座型号 Motor Frame Size	A	B	C	A	B	C	A	B	C
280	71	840	612	568	840	612	516	840	612	568
	80	840	612	568	840	612	516	840	612	568
	90	840	612	568	840	612	516	840	612	568
	100	840	612	568	840	612	516	840	612	568
	112	840	612	568	840	612	516	840	612	568
	132	840	612	568	840	612	516	840	612	568
160	840	612	568	840	612	516	840	612	568	
315	71	880	617	628	880	617	568	880	617	628
	80	880	617	628	880	617	568	880	617	628
	90	880	617	628	880	617	568	880	617	628
	100	880	617	628	880	617	568	880	617	628
	112	880	617	628	880	617	568	880	617	628
	132	880	617	628	880	617	568	880	617	628
160	880	617	628	880	617	568	880	617	628	
355	71	940	655	705	940	655	628	940	655	705
	80	940	655	705	940	655	628	940	655	705
	90	940	655	705	940	655	628	940	655	705
	100	940	655	705	940	655	628	940	655	705
	112	940	655	705	940	655	628	940	655	705
	132	940	655	705	940	655	628	940	655	705
160	940	655	705	940	655	628	940	655	705	
400	80	1130	736	786	1130	736	613	1130	736	786
	90	1130	736	786	1130	736	613	1130	736	786
	100	1130	736	786	1130	736	613	1130	736	786
	112	1130	736	786	1130	736	613	1130	736	786
	132	1130	736	786	1130	736	613	1130	736	786
	160	1130	736	786	1130	736	613	1130	736	786
180	1130	736	786	1130	736	613	1130	736	786	
450	90	1210	827	877	1210	827	776	1210	827	877
	100	1210	827	877	1210	827	776	1210	827	877
	112	1210	827	877	1210	827	776	1210	827	877
	132	1210	827	877	1210	827	776	1210	827	877
	160	1210	827	877	1210	827	776	1210	827	877
	180	1210	827	877	1210	827	776	1210	827	877
200	1210	827	877	1210	827	776	1210	827	877	
500	90	1290	918	981	1290	918	863	1290	918	981
	100	1290	918	981	1290	918	863	1290	918	981
	112	1290	918	981	1290	918	863	1290	918	981
	132	1290	918	981	1290	918	863	1290	918	981
	160	1290	918	981	1290	918	863	1290	918	981
	180	1290	918	981	1290	918	863	1290	918	981
200	1290	918	981	1290	918	863	1290	918	981	

**SYQ-R(K)**

		0°			90°			180°		
左旋 LG Left Hand										
右旋 RD Right Hand										
型号 Model	电机 机座型号 Motor Frame Size	A	B	C	A	B	C	A	B	C
560	90	1410	1030	1093	1410	1030	956	1410	1030	1093
	100	1410	1030	1093	1410	1030	956	1410	1030	1093
	112	1410	1030	1093	1410	1030	956	1410	1030	1093
	132	1410	1030	1093	1410	1030	956	1410	1030	1093
	160	1410	1030	1093	1410	1030	956	1410	1030	1093
	180	1410	1030	1093	1410	1030	956	1410	1030	1093
	200	1410	1030	1093	1410	1030	956	1410	1030	1093
630	90	1510	1157	1220	1510	1157	1062	1510	1157	1220
	100	1510	1157	1220	1510	1157	1062	1510	1157	1220
	112	1510	1157	1220	1510	1157	1062	1510	1157	1220
	132	1510	1157	1220	1510	1157	1062	1510	1157	1220
	160	1510	1157	1220	1510	1157	1062	1510	1157	1220
	180	1510	1157	1220	1510	1157	1062	1510	1157	1220
	200	1510	1157	1220	1510	1157	1062	1510	1157	1220
710	100	1730	1303	1366	1730	1303	1491	1730	1303	1366
	112	1730	1303	1366	1730	1303	1491	1730	1303	1366
	132	1730	1303	1366	1730	1303	1491	1730	1303	1366
	160	1730	1303	1366	1730	1303	1491	1730	1303	1366
	180	1730	1303	1366	1730	1303	1491	1730	1303	1366
	200	1730	1303	1366	1730	1303	1491	1730	1303	1366
	225	1730	1303	1366	1730	1303	1491	1730	1303	1366
800	100	1870	1468	1548	1870	1468	1330	1870	1468	1548
	112	1870	1468	1548	1870	1468	1330	1870	1468	1548
	132	1870	1468	1548	1870	1468	1330	1870	1468	1548
	160	1870	1468	1548	1870	1468	1330	1870	1468	1548
	180	1870	1468	1548	1870	1468	1330	1870	1468	1548
	200	1870	1468	1548	1870	1468	1330	1870	1468	1548
	225	1870	1468	1548	1870	1468	1330	1870	1468	1548
900	132	2170	1648	1748	2170	1648	1748	2170	1648	1748
	160	2170	1648	1748	2170	1648	1748	2170	1648	1748
	180	2170	1648	1748	2170	1648	1748	2170	1648	1748
	200	2170	1648	1748	2170	1648	1748	2170	1648	1748
	225	2170	1648	1748	2170	1648	1748	2170	1648	1748
	250	2170	1648	1748	2170	1648	1748	2170	1648	1748
	280	2170	1648	1748	2170	1648	1748	2170	1648	1748
1000	132	2300	1810	1910	2300	1810	1641	2300	1810	1910
	160	2300	1810	1910	2300	1810	1641	2300	1810	1910
	180	2300	1810	1910	2300	1810	1641	2300	1810	1910
	200	2300	1810	1910	2300	1810	1641	2300	1810	1910
	225	2300	1810	1910	2300	1810	1641	2300	1810	1910
	250	2300	1810	1910	2300	1810	1641	2300	1810	1910
	280	2300	1810	1910	2300	1810	1641	2300	1810	1910



## SYQ 系列风机运行极限

## SYQ Series Fan Operational Limits

			200	225	250	280	315	355	400	450	500	560	630	710	800	900	1000
极限吸收功率 Max. absorbed Power	L	KW	1.5	1.5	2	/	/	/	/	/	/	/	/	/	/	/	/
	R	KW	2	3	3	5.5	4.8	5.5	6.0	8.0	12	14	20	20	/	/	/
	K	KW	/	/	/	8	8	15	15	15	22	30	35	40	30	43	55
	Z	KW	/	/	/	/	/	/	/	/	30	38.5	40	60	65	65	80
	R2	KW	/	/	/	5.5	6.5	8.5	8.5	12	13	14	18	18	/	/	/
	K2	KW	/	/	/	/	/	13	13	18.5	22	32	34	45	45	45	65
极限转速 Max.R.P.M	L	rpm	4500	3700	3500	/	/	/	/	/	/	/	/	/	/	/	/
	R	rpm	4900	4500	4100	4000	3200	2800	2400	2200	2000	1800	1700	1400	/	/	/
	K	rpm	/	/	/	4500	4000	3800	3200	2800	2500	2400	2000	1700	1300	1200	1100
	Z	rpm	/	/	/	/	/	/	/	/	2800	2600	2200	2000	1600	1400	1300
	R2	rpm	/	/	/	3200	2800	2600	2100	1800	1600	1400	1200	1000	/	/	/
	K2	rpm	/	/	/	/	/	3000	2400	2200	2000	1800	1600	1400	1200	1000	900
极限温度 (最低-20℃) Air Temperature Limits (Min-20℃)	L	Max.	85	85	85	/	/	/	/	/	/	/	/	/	/	/	/
	R/R2	℃	85	85	85	85	85	85	85	85	85	85	85	85	/	/	/
	K/K2	Max.	/	/	/	85	85	85	85	85	85	85	85	85	85	85	85
	Z	℃	/	/	/	/	/	/	/	/	85	85	85	85	85	85	85
风机重量 Fan Weight	L	Kg	8	10	16	/	/	/	/	/	/	/	/	/	/	/	/
	R	Kg	10	12	18	22	32.6	42.7	50.6	67.5	84.2	142	168	223	/	/	/
	K	Kg	/	/	/	32	42.6	54.7	63.6	82.5	104.2	171	197	271	300	481.5	530
	Z	Kg	/	/	/	/	/	/	/	107	174	200	274	304	485	535	
	R2	Kg	/	/	/	46	67	91	107	143	176	300	352	462	/	/	/
	K2	Kg	/	/	/	/	/	111	127	173	217	358	410	558	616	989	1086

## SYH 系列离心式空调风机

## Centrifugal Ventilators

浙江亿利达风机股份有限公司特此证明，此处所示 SYH 系列离心风机获得了加盖 AMCA 印章的授权。所示额定值系根据 AMCA 出版物 211 和 AMCA 出版物 311 所进行测试和程序确定，并符合 AMCA 认证额定值计划的要求。

这里描述的所有离心风机都已经取得了 AMCA 印章，他们的认证数据见第 137 页到 152 页。

Zhejiang Yilida Ventilator Co.,Ltd. certifies that the SYH Series fans shown herein are licensed to bear the AMCA Seal. The ratings shown are based on tests and procedures performed in accordance with AMCA Publication 211 and AMCA Publication 311 and comply with the requirements of the AMCA Certified Ratings Program.

All the Centrifugal Fans described herein are licensed to bear the AMCA Seal, and their certified ratings are shown on pages 137 through 152.



本样本中所述的风机特性,如尺寸、性能参数等,本公司保留更改的权利,恕不另行通知;如有不明之处,请来电询问。  
This fan features described in the sample, such as size, performance parameters, the Company reserves the right to change without notice; if unknown place, please call us.

## 概述

SYH 系列后向离心式空调风机，叶轮采用后向机翼型叶片，具有通用性强、效率高、噪声低、耗能少、安全性好的特点。是各类中央空调机组及其它暖通空调、净化、通风等通风系统理想的配套产品。该样本中列出的 16 种规格风机，流量范围从 2000m<sup>3</sup>/h-300000m<sup>3</sup>/h，全压从 200Pa-3000Pa，均通过了 AMCA 国际认证，并取得 AMCA 印章。

## Summary

The SYH Series of centrifugal fans with backward airfoil blade, They are licensed to bear the AMCA Seal for air performance, sound, and FEG. The SYH Series includes 16 models as described in this catalogue. The volume flow of the SYH Series ranges from 2,000 m<sup>3</sup>/h to 300,000 m<sup>3</sup>/h, the total pressure ranges from 200 Pa to 3,000 Pa, Some of the features and characteristics of these fans are: a wide range of applications, high efficiency, low noise, and low power consumption. These fans are ideal for use in central air-conditioning systems, in purifiers. They are also suitable for use in a variety of other ventilation applications.

## 命名方式

SYH 500 K

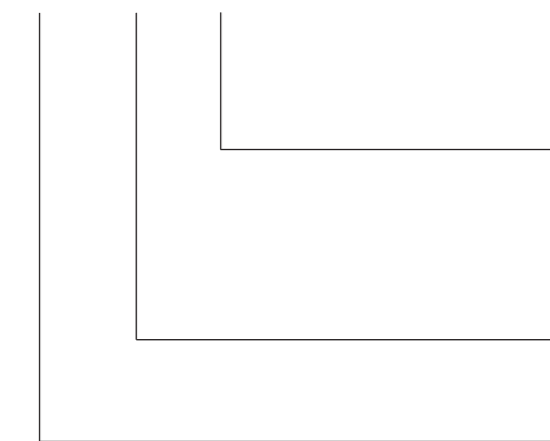

## Nomenclature

- 结构型式 Construction type
- R 型(基本型) Type R (Basic Model)
- K 型(加强型) Type K (Heavy Duty Model)
- Z 型(超重型) Type Z (Extra-heavy Heavy Model)
- 叶轮名义直径( mm) Nominal diameter of impeller (mm)
- 后向机翼型离心风机系列代号 Fan series with backward airfoil blades

## 产品型式

### 1. 旋向

SYH 系列风机可分为左旋(LG)和右旋(RD)两种旋转方式，从风机皮带轮一端正视，叶轮顺时针旋转的称为右旋风机，逆时针旋转的称为左旋风机。

### 1. Rotation

SYH series fans have two direction of rotations, left-hand rotation (LG) and right-hand rotation (RD); Viewing from drive side, if the impeller rotates clockwise, it is left hand (LG) rotation. If the impeller rotates counter clockwise, it is right-hand (RD).

## 2. 出风口方向

SYH 系列出风口可按图 1 所示制成 0°、90°、180°、270° 四种出风方向。

图1 (Fig 1)

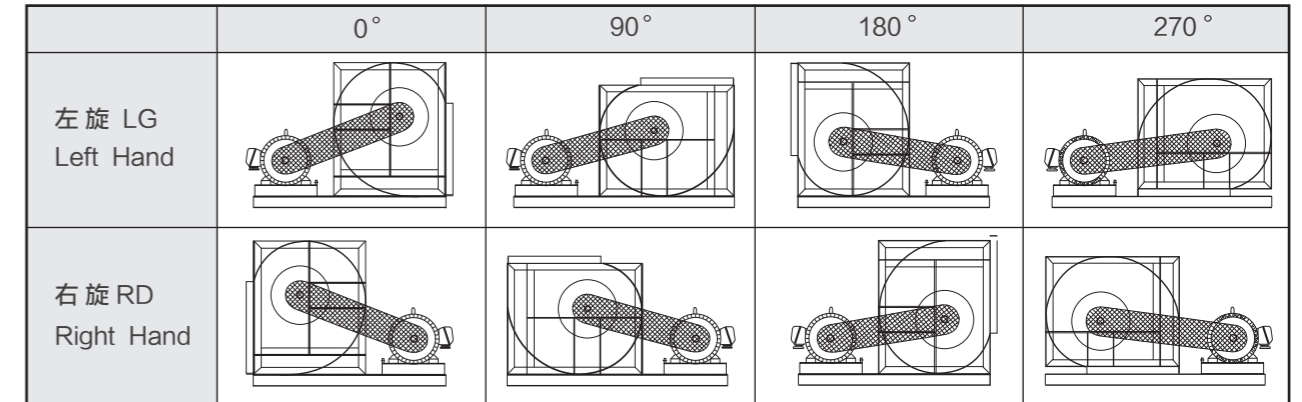

## 2. Discharge Direction

As shown in Fig1, SYH Series fans can be constructed in four discharge directions: 0°, 90°, 180°, and 270°.

## 3. 结构形式

SYH 系列风机可按图 2 所示制成 R 型、K 型、Z 型、L2 型、R2 型。

图2 (Fig 2)

风机类型 Fan Type	机号 Fan Size	风机示意图 Fan Diagram	轴承实物图 Bearing Type
R 型 TYPE R	280-710		
K 型 TYPE K	280-1000		
Z 型 TYPE Z	280-1000		
Z 型 TYPE Z	1000-1600		
R2 型 TYPE R2	200-500		
K2 型 TYPE K2	200-560		

## 3. Type of construction

As shown in Fig 2, SYH series fans can be divided into Category R . K, Z, Category L2 . R2.

## 产品结构

SYH 系列风机主要由机壳、叶轮、框架、轴承及轴构成。出口法兰（为可选件）。

### 1. 机壳

机壳采用热镀锌钢板制造，侧板具有符合空气动力的外形，进风口整体拉伸成型，蜗板采用点焊或“Pittsburg seam locking”的连接方式与侧板连成一体。

### 2. 叶轮

后向叶轮采用优质冷轧钢板制成，按三元流理论设计的机翼型叶片焊接在高精度激光切割机床加工的中盘和端圈上，整体喷塑。所有叶轮进行静平衡和动平衡测试，内控精度达到 G2.5 级 (ANSI/AMCA 204-05)。

### 3. 框架

R 型风机框架采用热镀锌钢板剪切、折弯制成，TOX 连接保证了所需的尺寸精度和应有的刚度；K 型风机框架由角钢和扁钢冷弯焊接制成；Z 型风机框架由加宽加厚的角钢扁钢焊接制成。轴承安装位进行对称铣平面加工，表面喷塑处理，以保证足够的刚度和强度，同时保证安装轴和轴承的同心度。

### 4. 轴承

SYH 系列风机均采用优质滚珠轴承，并根据噪声最低来选择，该轴承设有加润滑油的孔，已预先加润滑油并自动对中；L、R 型风机的轴承安装在轴承支架上，并设有防振垫圈；K 型风机则采用带座向心球轴承；Z 型风机采用重载荷的双列滚柱轴承的轴承箱结构。轴承寿命为  $L_{10} \geq 100000$  小时。

### 5. 轴

风机轴采用 40Cr 低合金钢，经车、调质热处理、磨削制成，强度高，挠度小，严格控制轴径尺寸公差及形位公差，每根轴均经过涂覆防锈处理。轴尺寸设计应满足第一临界转速至少为风机最大运行转速的 1.4 倍。

### 6. 出风口法兰

法兰采用热镀锌钢板制成，法兰与蜗壳的连接采用 TOX 免焊工艺，外观精美，并具有足够的刚度与强度。

## Construction of Product

SYH series fans are mainly constructed of housing, impeller, frame, bearing and shaft. Outlet flange (is optional).

### 1. Housing

The housing is made of hot galvanized steel sheet. The side plates include inlets cones that are designed with the best aerodynamics for inlet condition. The scroll is fixed to the side plates by spot welding or "Pittsburg seam locking."

### 2. Impeller

Backwards curved airfoil impeller is constructed of high-grade cold-roll steel sheets, according to the three-dimensional flow theory, the impeller is fixed on the center plate and on the end ring with welding by high precision laser cutting machine. The unity of the impeller is spraying by plastic. All impellers are balanced to ANSI/AMCA Standard 204-05. Yilida's internal standard is G2.5 or higher for wheel balancing.

### 3. Frame

The frames for type R construction are made of galvanized steel angle iron bars. The cutting and bending of the frame parts, as well as the TOX connections, are formed with the use of toolings to ensure the high accuracy and the rigidity of the frames; The frames for K constructions are welded by angle steel and flat steel, the frames for Z constructions are welded by thicker angle steel and flat steel, and finished with polyester coating in order to ensure sufficient rigidity and strength. The bearing supports are machined to ensure proper installation and alignments of the bearings.

### 4. Bearings

Ball bearings are used in all of the SYH Series fans. These are high-quality bearings and selected to minimize the fan noise levels. The bearings are pre-lubricated, sealed, and self-centering. For type R and L constructions, the bearings are supplied with lubrication fittings. For type K constructions, the bearings are supplied with radial bearing. For type Z, the bearings are supplied with heavy lift double-row ball bearing. Yilida bearing service life ( $L_{10}$ ) are over 100,000 hours ( $L_{10} \geq 100000$  hours).

### 5. Shaft

The shafts are made of 40 Cr carbon steel bars. The shafts are rough machined and then stress relieved with heat treatment before final machining. The shaft diameters are machined to very accurate tolerance levels, and they are fully checked to ensure precision fit. Each shaft is made turned, ground and polished. They are coated after assembly to provide corrosion resistance. Shaft size should be designed to meet the first critical speed of at least fan maximum running speed 1.4 times.

### 6. Outlet Flange

The outlet flange is made of galvanized steel. The connections of the flange components to the scroll are made using a TOX non-welding process. This maintains a good flange appearance while also providing sufficient strength and rigidity.

## 风机性能

### 1、风机选型示意图例

型号 Type	SYH710K
风量 Volume	$q_v=35000\text{m}^3/\text{h}$
全压 Total Pressure	$P_{IF}=1200\text{Pa}$
动压 Dynamic Pressure	$P_{dF}=87\text{Pa}$
出口速度 Outlet Velocity	$C=12.06\text{m/s}$
风机转速 Fan Speed	$n=1312\text{r/min}$
轴功率 Shaft Power	$P_{sh}=16.24\text{KW}$
A声功率级 A Sound Power Level	$L_{wA}=94\text{dB(A)}$
全压效率 Total Efficiency	$\eta_{IF}=78.1\%$

## Performance Chart

### 1. Fan Performance Curve

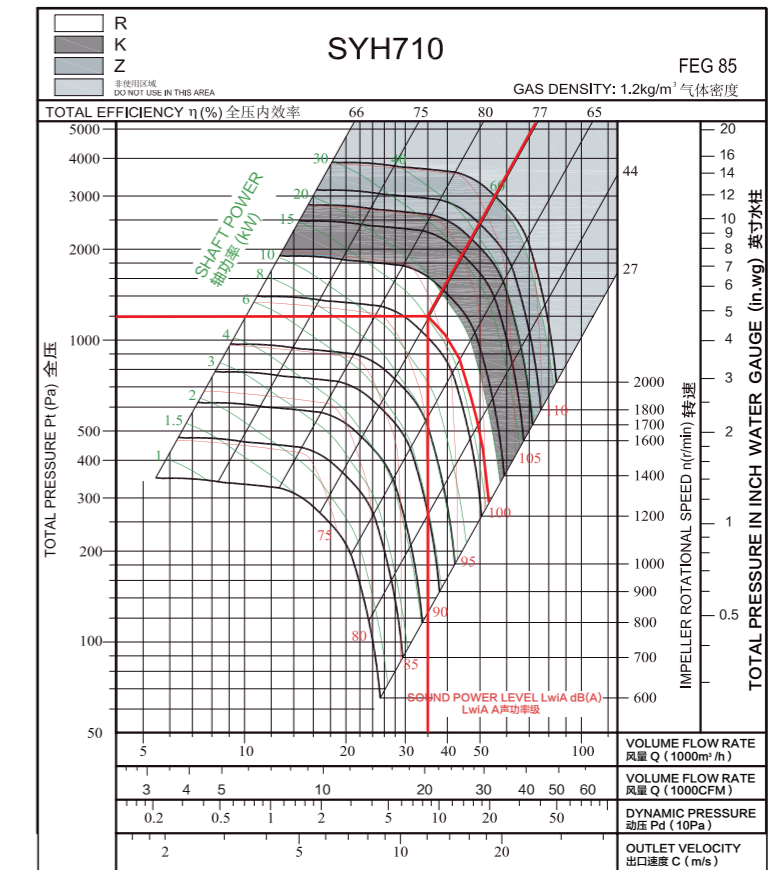



## 2、电机的选配

性能曲线图上的功率 Psh 是指风机的轴功率。

配套电机的功率:  $P_{sh.p} = P_{sh} \times K \div \eta_{me}$

风机传动效率的取值方法可参照表 1,

电机容量安全系数的取值方法可参照表 2。

表1 (Table 1)

风机传动方式	Drive Type	$\eta_{me}$
电机直联传动	Motor Direct Drive	1
联轴器直联传动	Coupling Direct Drive	0.98
三角皮带传动	V-Belt Drive	0.95

## 3.双联风机的性能计算

L2 型、R2 型、K2 型双联风机性能与 L 型、R 型、K 型风机曲线上所示性能比较,在压力相同的情况下,双联风机性能如下:

风量 x 2	转速 x 1.05
轴功率 x 2.15	噪声 + 3 dB

双联风机的性能未获得 AMCA International 授权。

## 2. Motor selection

The power (Psh) on the performance chart refers to the shaft power of the fan.

The rated power of the drive motor equals the total required shaft input multiplied by the safety factor:  $P_{sh.p} = P_{sh} \times K \div \eta_{me}$   
The value of mechanical drive efficiency can be obtained from Table 1.

The required safety factors is provided in Table 2.

表2 (Table 2)

电机功率	Power of electric motor (Kw)	K值Value k
$\leq 2.2Kw$		1.2
$\leq 7.5Kw$		1.15
$\geq 11Kw$		1.1

## 3.The twin fan performance calculation

Comparing the performance of the twin fan of Category L2, R2 and K2 with the comparable single fan performance of L, R and K. In the same condition of pressure, the twin fans' performance are as the following:

Volume x 2	RPM x 1.05
Shaft Power x 2.15	Noise + 3 dB

Performance of twin ventilators are not licensed by AMCA International.

8. 关掉风机, 移动电机座以调整张紧度, 当风机工作时, 皮带紧的一边是两个皮带轮连成的一条直线, 松的一边有轻微弧形。

图 3 (Fig2)

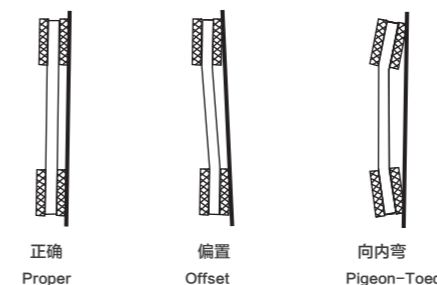

8. Switch off the fan, adjust the belt tension by moving the motor base. When in operation, the tight side of the belts should be in a straight line from sheave to sheave and there should be a slight bow on the slack side.



## B) 皮带松紧度

合适的皮带松紧度对使用寿命来说很重要, 太紧会给皮带和轴承带来额外的负载, 降低它们的使用寿命, 太松会出现皮带打滑现象而产生热能并降低使用寿命。

皮带松紧度量具用来判断皮带是否松紧合适。量具本身带有一个尺表, 根据皮带轮中心距和皮带横截面确定皮带张紧力的大小, 如图 4 和表 3。

如没有皮带张紧度量具, 应调节皮带松紧至风机启动时皮带不发生尖叫声为止, 如发生短促的叫声是允许的。

拉紧皮带后、开动风机之前, 重新检查皮带轮的对齐情况, 如右必要则重新调整对齐。新皮带在开始使用时可能有点拉伸, 则应在运行几天后重新检查皮带张紧度。

## B) Belt tension

A proper level of belt tension is required in order to obtain a satisfactory belt life. If the belt tension level is too high, excessive loads will be imposed on the belts and the bearing, and this will reduce the lives of both of these components. If the belt tension level is too low, the belt will slip. Belt slippage generates a large amount of heat, and this heat will drastically reduce the life of a belt.

Belt-tensioning gauges can be used to determine whether the belts are tensioned properly. A chart is normally supplied with the gauge which indicates the ranges of forces required to deflect the belts by a given amount to obtain the proper belt tension level. The required forces are based upon the center distance of the sheaves and the belt cross-section. The belts are properly tensioned when the forces required to deflect the belt are within the specified range, see Fig 4 and Table 3.

If a belt-tensioning gauge is not available, then the belt should be tightened just enough so that the belt does not squeal when the ventilator is started. A very short period of noise during the starting of a ventilator is allowable, but a squeal lasting several seconds or longer is not acceptable. After tensioning the belts and before starting the fan, check to make sure that the sheaves are properly aligned. Realign the sheaves if necessary. Note that new belts may stretch a little during initial use, so the belt tension level should be checked after a few days of operation.

## 安装与维护

## Installation and Maintenance

### A) 皮带传动安装

1. 拆除风机轴端的保护并检查有无缺口和毛刺;
2. 检查风机和电机轴之间的平行度;
3. 中心距控制在  $0.7(d1+d2) < a < 2(d1+d2)$ , 前向风机皮带速度应控制在 10~15m/s; 后向风机皮带速度应控制在 25~35m/s;
4. 将皮带轮套在轴上滑进去, 不要敲击, 以免损伤轴承;
5. 用一根直尺把风机和电机上的带轮对齐并紧固;
6. 把皮带套进皮带轮, 不要撬、挤压, 以免损伤皮带;
7. 调整张紧度直至皮带看起来松紧适度, 风机运行几分钟后, 再调整皮带至合适的张紧度;

### A) V-belt drive Installation

1. Remove the protective coating from the ends of the fan shaft and ensure that the shaft ends are free of nick and burrs.
2. Check fan and motor shafts for alignment.
3. The center distance must be controlled as  $0.7(d1+d2) < a < 2(d1+d2)$ , The belt speed of forward curve fan should be more than 10m/s, but less than 15m/s, ( $10 < v < 15m/s$ ). The belt speed of backward curve fan should be more than 25m/s, but less than 35m/s ( $25 < v < 35m/s$ ).
4. Slide sheaves on to the shafts, Do not hammer the sheaves on to the shafts with force as this may result in bearing damage.
5. Align fan and motor sheaves with a straight-edge, and tighten the sheaves.
6. Place belts over the sheaves with care. Do not bend or squeeze the belts or it might get damaged.
7. Adjust the belt tension until the belts appear snug. Run the unit for a few minutes and allow the belts to set properly.

与中心距有关的皮带张紧度指示

Belt tension indicator applied to mid centre distance.

表4 (Fig4)



表3 (Table3)

皮带截面 Belt Section	使皮带向下移动16mm径向距离1米所需的力 Force required to deflect belt 16mm per metre of span		
	张紧力 (小皮带轮直径) Small Pulley Diameter (mm)	牛顿 Newtonian (N)	千克力 Kilogram force (Kgf)
SPZ	56-95	13-20	1.3-2.0
	100-140	20-25	2.0-2.5
SPA	80-132	25-35	2.5-3.6
	140-200	35-45	3.6-4.6
SPB	112-224	45-65	4.6-6.6
	236-315	65-85	6.6-8.7
SPC	224-335	85-115	8.7-11.7
	375-560	115-150	11.7-15.3
A	80-140	10-15	1.1-1.5
B	125-200	20-30	2.0-3.1

### C) 轴承润滑

风机使用带座轴承，可通过加油嘴注入润滑油。润滑油有效期取决于油脂类型、轴承的转速和工作温度。判断是否加油的最好办法是当加新油时观察清除下来的旧油脂，可延长换油脂的间隔，如果清除下来的油脂比新的黑得多表明油脂已氧化，应缩短换油脂的间隔。

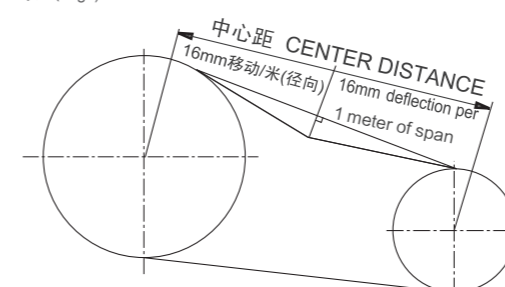
### C) Bearing Lubrication

The fan bearings are filled with lubricant when they ship from the factory, so the bearings do not require any additional grease to be supplied before starting the fan. The fans that are equipped with pillow block bearing are provided with lubrication fittings, and these fittings allow for additional lubrication to be supplied to the bearings at regular intervals. The allowable period of time between lubrication of these bearings depends upon the operating speeds and temperatures of the bearing as well as on the type of lubrication. It is recommended to inspect the condition of the grease that is discharged from the bearings when new grease is added. If the discharged grease looks similar to the new grease, then a longer period of time between lubrications is possible. If the discharged grease is much darker than the new grease, this indicates that the grease is being oxidized and more frequent lubrications of the bearings are required.

### 说明

- 1). 订货时须注明风机型号、转速、风量、风压、出风口方向和旋转方向。若需配套皮带、皮带轮、电机、安装底座等配件及其它特殊要求可在订货时提出。
- 2). 在安装前应对风机各部件进行检查，对叶轮、主轴和轴承等主要机件应重点细致检查，如有损伤应修复后再安装使用。
- 3). 检查机壳和其它壳体内部，不应有掉入、遗留的工具和杂物。
- 4). 风机正式运转前，需检查电机的转向是否符合风机转向的要求。
- 5). 风管与出风口之间应采用软连接，接头不得拉紧。
- 6). 风机安装后用手或杠杆拨动叶轮，检查是否过紧或碰撞现象，确认无这些现象时方可进行试转。
- 7). 风机配用电动机功率是指在特定工况下，风机内功率加上机械损失与电机容量安全系数而言，并非出风口全敞开时所需的功率。为防止电机超功率运行而烧毁，严禁风机出风口或进风口不接管路或未加外界任何阻力进行空运转。
- 8). 风机在无较大腐蚀性气体、不含酸（碱）性和尘粒物质小于 150mg/m<sup>3</sup> 的气体、温度小于 85℃ 大于 -20℃ 的气体环境下使用，风机在运输装卸过程中应小心轻放，防止碰撞挤压。

### Instructions

- 1) When placing the order, it is necessary to state the type of fan, speed, air volume, air pressure, discharge direction, rotation direction, type of electric motor and its specifications.
- 2) Prior to installation, the fan should be carefully inspected. Special care should be taken in checking the shaft, impeller and bearings. If there is an indication of any damage, the damaged parts should be repaired or replaced before the fan is installed or commissioned.
- 3) The inside of the scroll and casing need to be checked to make sure that there are no foreign objects inside the housing, such as tools or loose parts.
- 4) The rotational directions of the motor and impeller should be checked to ensure that they are in compliance with the specification and purchase orders.
- 5) A flexible connector should be used between the fan out let flange and its mating ductwork. The flex connector should not be over-stretched.
- 6) Following the installation, the impeller should be turned by hand or with the use of a wrench to make sure that it turns freely without colliding with other parts of the fan. Once all this is done, the fan can be commissioned normally.
- 7) The rated motor power as calculated herein might not be sufficient to drive the fan with an unrestricted discharge flow. Operating the fan with an unrestricted discharge outlet will result in flow rate that exceeds the specified fan capabilities. Such operation will quickly burn the motor and damage the fan. Great care must be taken in operating the fan to make sure that the maximum rated flows, as provided on the performance charts in this catalog, are not exceeded.
- 8) The fan is limited for use in areas where air substances are non-corrosive, non-toxic and non-erosive and where dust particles are less than 150mg/m<sup>3</sup> with a temperature between -20°C and 85°C. Special care should be taken during transportation, load and unload.

### 技术参数

Wheel diameter	叶轮直径	D = 280 mm	Fan weight	风机质量	m = 32 kg
Moment of inertia	转动惯量	J = 0.082kg · m <sup>2</sup>	Speed limit	极限转速	n <sub>max</sub> = 4500 r/min

### Technical Data

### 性能曲线

经认证的性能是B类安装：自由入口，管道出口。功率额定值(kW)不包括传输损失。各项性能额定值不包括附属物(附件)的影响。所示A加权声音性能额定值已按AMCA International标准301计算。所示值为安装类型B：自由入口，管道出口的声功率级（入口L<sub>wA</sub>）。

### Performance Curve

Performance certified is for installation type B: free inlet, ducted outlet. Power rating (kW) does not include transmission losses. Performance ratings do not include the effects of appurtenances (accessories). The A-weighted sound ratings shown have been calculated per AMCA International Standard 301. Values shown are for inlet L<sub>wA</sub> sound power levels for installation type B: free inlet, ducted outlet.

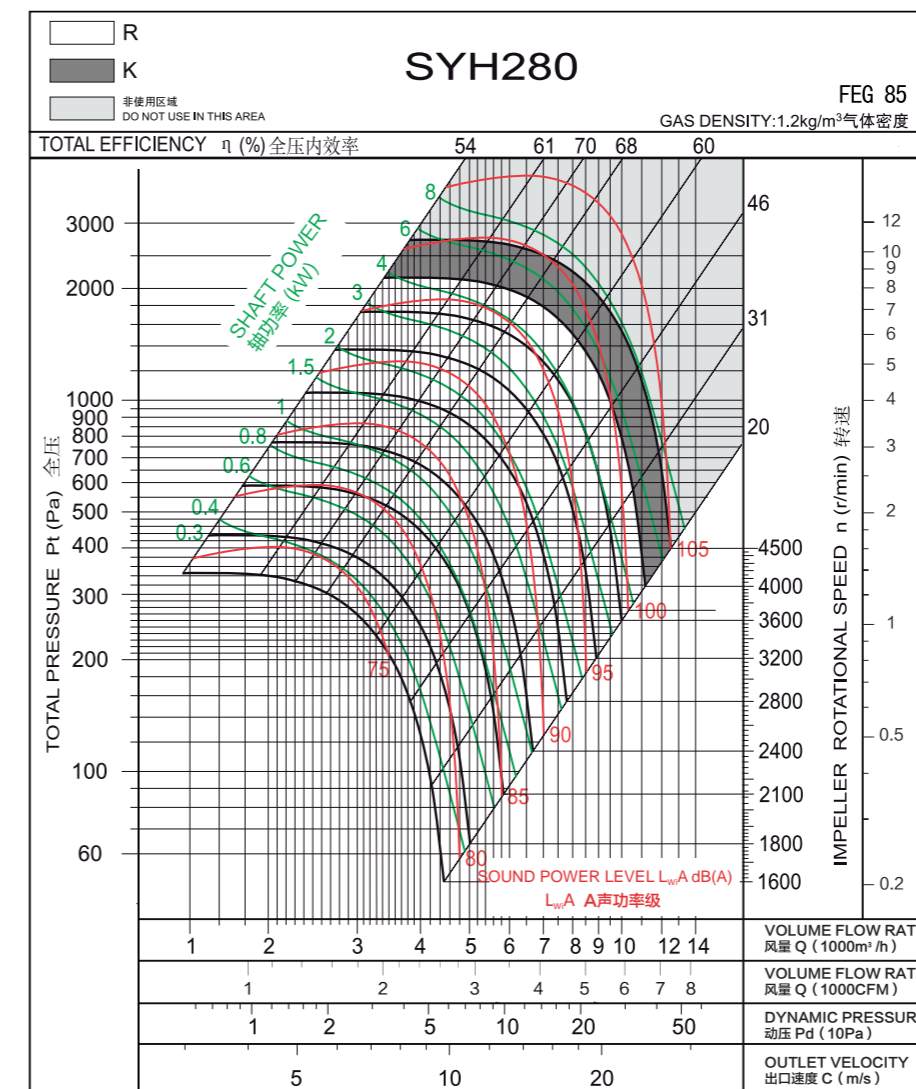

Measured in installation B according to AMCA Standard 210:

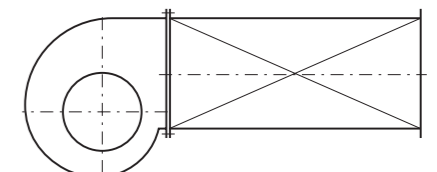

## 技术参数

## Technical Data

Wheel diameter 叶轮直径	D = 315 mm	Fan weight 风机质量	m = 42.6kg
Moment of inertia 转动惯量	J = 0.012kg · m <sup>2</sup>	Speed limit 极限转速	n <sub>max</sub> = 4000r/min

## 技术参数

## Technical Data

Wheel diameter 叶轮直径	D = 355 mm	Fan weight 风机质量	m = 54.7kg
Moment of inertia 转动惯量	J = 0.27kg · m <sup>2</sup>	Speed limit 极限转速	n <sub>max</sub> = 3800 r/min

## 性能曲线

## Performance Curve

经认证的性能是B类安装：自由入口，管道出口。功率额定值(kW)不包括传输损失。各项性能额定值不包括附属物(附件)的影响。所示A加权声音性能额定值已按AMCA International标准301计算。所示值为安装类型B：自由入口，管道出口的声功率级（入口L<sub>wA</sub>）。

Performance certified is for installation type B: free inlet, ducted outlet. Power rating (kW) does not include transmission losses. Performance ratings do not include the effects of appurtenances (accessories). The A-weighted sound ratings shown have been calculated per AMCA International Standard 301. Values shown are for inlet L<sub>wA</sub> sound power levels for installation type B: free inlet, ducted outlet.

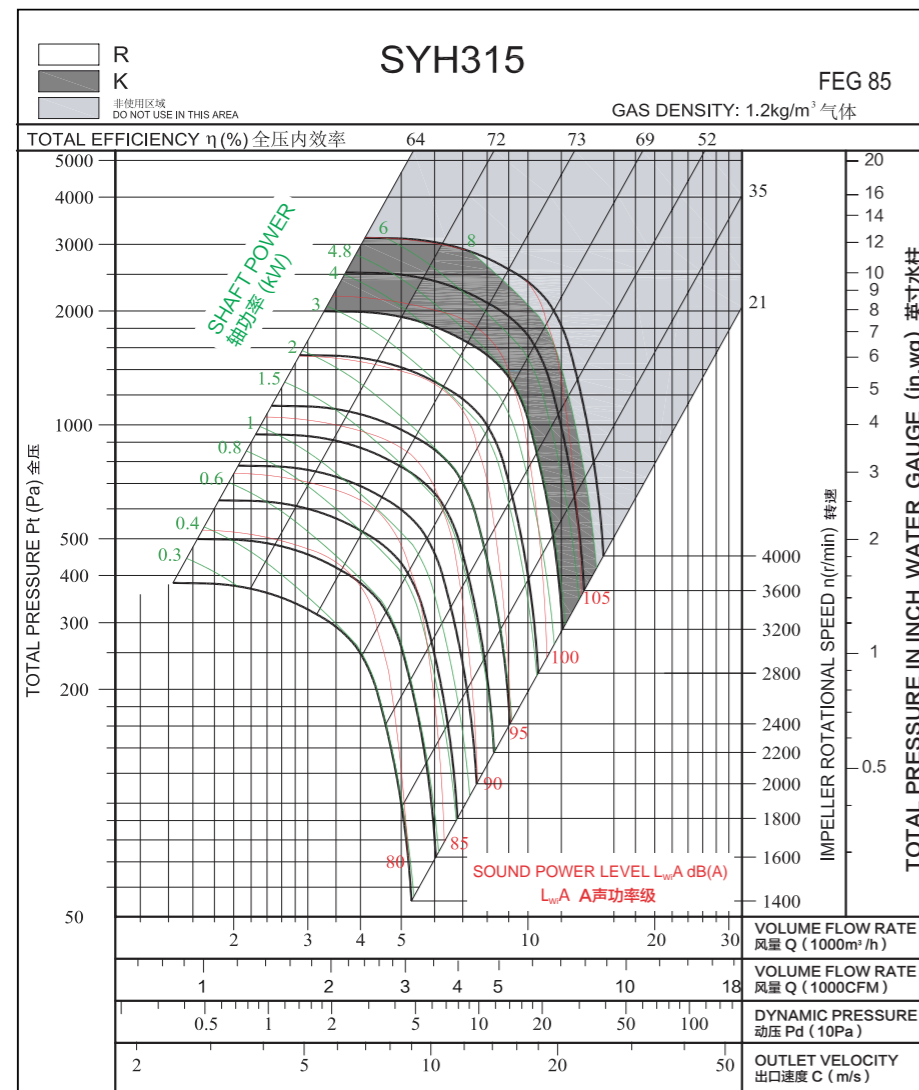

## 性能曲线

## Performance Curve

经认证的性能是B类安装：自由入口，管道出口。功率额定值(kW)不包括传输损失。各项性能额定值不包括附属物(附件)的影响。所示A加权声音性能额定值已按AMCA International标准301计算。所示值为安装类型B：自由入口，管道出口的声功率级（入口L<sub>wA</sub>）。

Performance certified is for installation type B: free inlet, ducted outlet. Power rating (kW) does not include transmission losses. Performance ratings do not include the effects of appurtenances (accessories). The A-weighted sound ratings shown have been calculated per AMCA International Standard 301. Values shown are for inlet L<sub>wA</sub> sound power levels for installation type B: free inlet, ducted outlet.

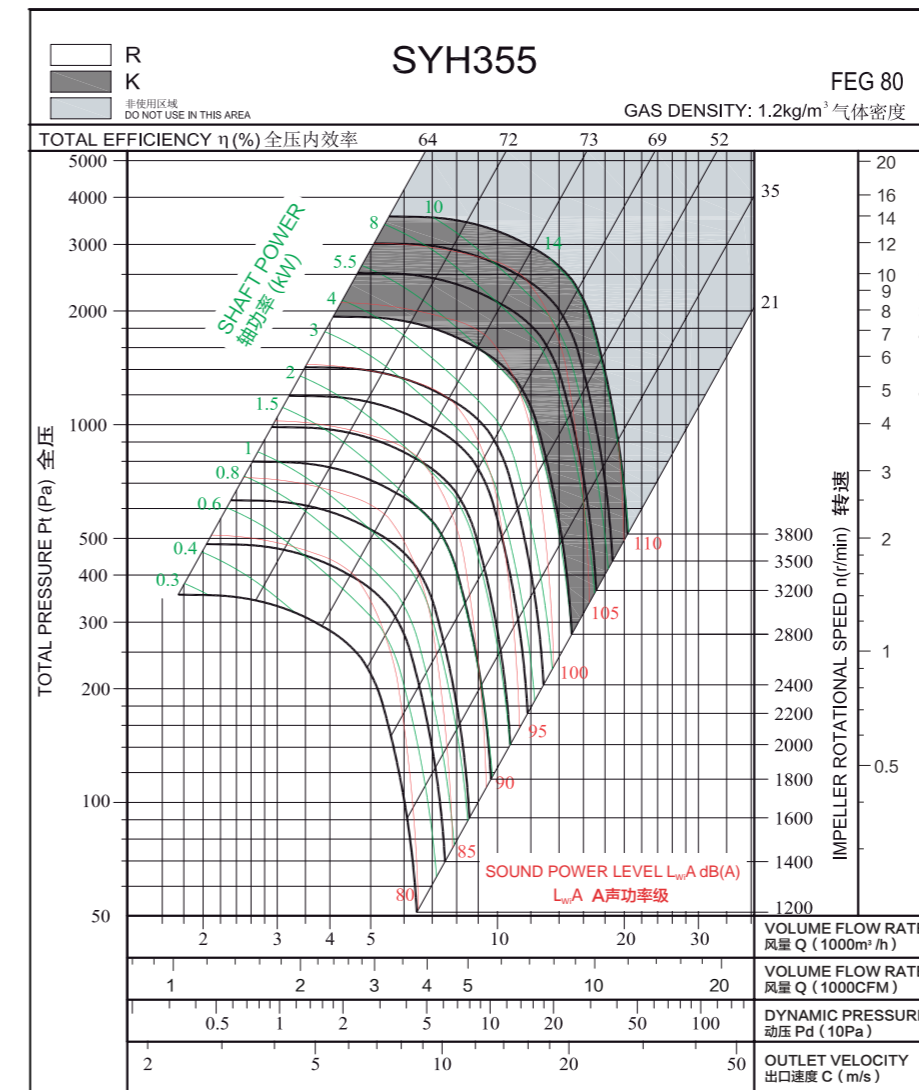



## 技术参数

## Technical Data

Wheel diameter 叶轮直径	D = 400 mm	Fan weight 风机质量	m = 63.6 kg
Moment of inertia 转动惯量	J = 0.38kg·m <sup>2</sup>	Speed limit 极限转速	n <sub>max</sub> = 4500 r/min

## 技术参数

## Technical Data

Wheel diameter 叶轮直径	D = 450 mm	Fan weight 风机质量	m = 54.7kg
Moment of inertia 转动惯量	J = 0.27kg·m <sup>2</sup>	Speed limit 极限转速	n <sub>max</sub> = 2800 r/min

## 性能曲线

## Performance Curve

经认证的性能是B类安装：自由入口，管道出口。功率额定值(kW)不包括传输损失。各项性能额定值不包括附属物(附件)的影响。所示A加权声音性能额定值已按AMCA International标准301计算。所示值为安装类型B：自由入口，管道出口的声功率级（入口L<sub>wA</sub>）。

Performance certified is for installation type B: free inlet, ducted outlet. Power rating (kW) does not include transmission losses. Performance ratings do not include the effects of appurtenances (accessories). The A-weighted sound ratings shown have been calculated per AMCA International Standard 301. Values shown are for inlet L<sub>wA</sub> sound power levels for installation type B: free inlet, ducted outlet.

## 性能曲线

## Performance Curve

经认证的性能是B类安装：自由入口，管道出口。功率额定值(kW)不包括传输损失。各项性能额定值不包括附属物(附件)的影响。所示A加权声音性能额定值已按AMCA International标准301计算。所示值为安装类型B：自由入口，管道出口的声功率级（入口L<sub>wA</sub>）。

Performance certified is for installation type B: free inlet, ducted outlet. Power rating (kW) does not include transmission losses. Performance ratings do not include the effects of appurtenances (accessories). The A-weighted sound ratings shown have been calculated per AMCA International Standard 301. Values shown are for inlet L<sub>wA</sub> sound power levels for installation type B: free inlet, ducted outlet.

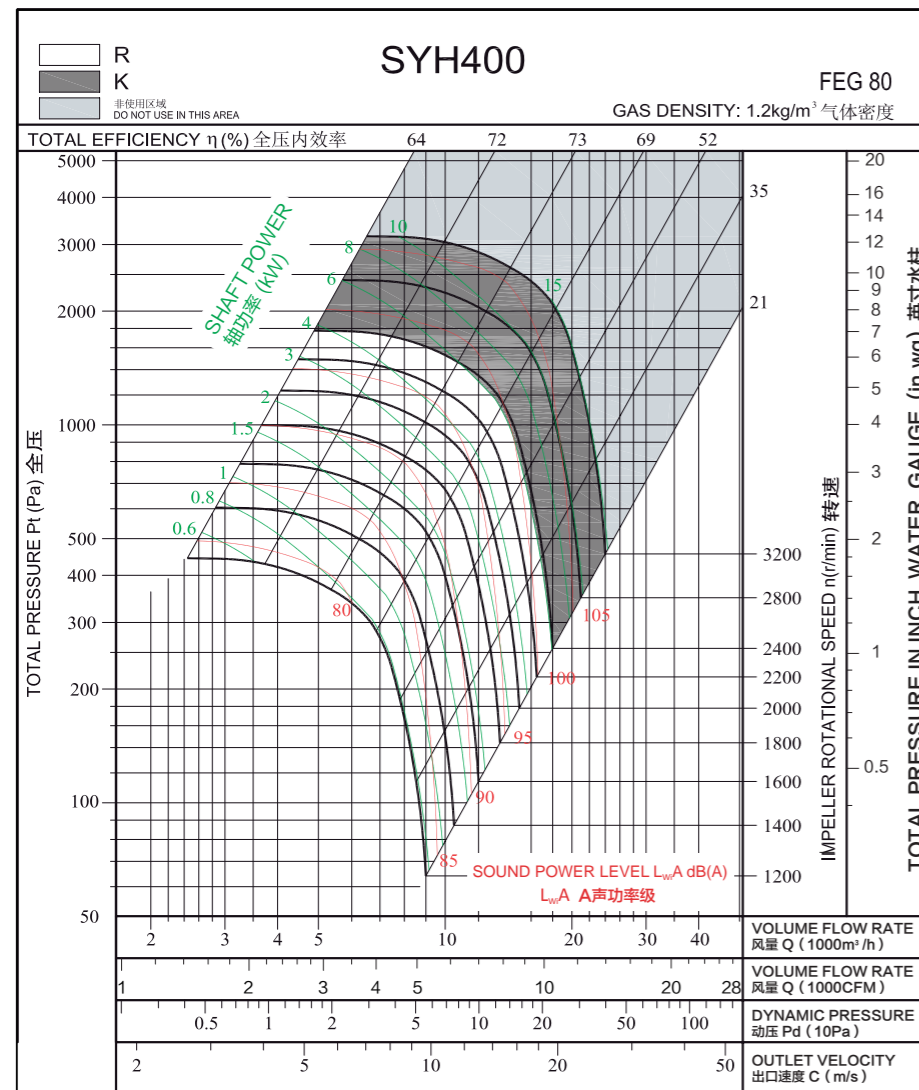

Measured in installation B according to AMCA Standard 210:

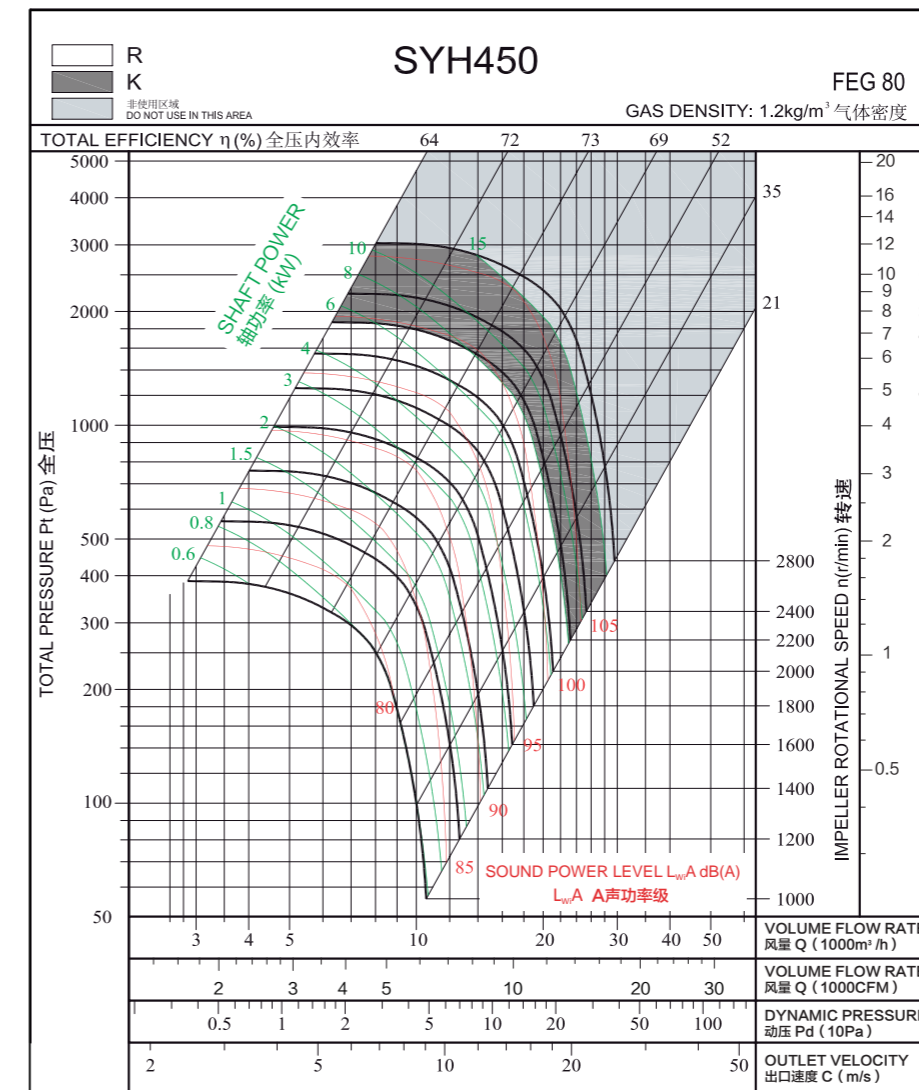
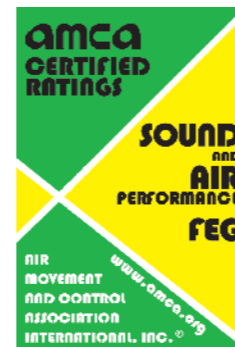
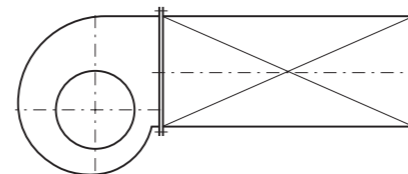

Measured in installation B according to AMCA Standard 210:

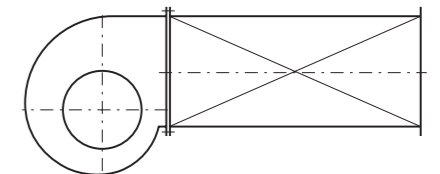

## 技术参数

## Technical Data

Wheel diameter 叶轮直径	D = 500 mm	Fan weight 风机质量	m = 104.2 kg
Moment of inertia 转动惯量	J = 0.95 kg·m <sup>2</sup>	Speed limit 极限转速	n <sub>max</sub> = 2800 r/min

## 技术参数

## Technical Data

Wheel diameter 叶轮直径	D = 560 mm	Fan weight 风机质量	m = 171kg
Moment of inertia 转动惯量	J = 1.8kg·m <sup>2</sup>	Speed limit 极限转速	n <sub>max</sub> = 2500 r/min

## 性能曲线

## Performance Curve

经认证的性能是B类安装：自由入口，管道出口。功率额定值(kW)不包括传输损失。各项性能额定值不包括附属物(附件)的影响。所示A加权声音性能额定值已按AMCA International标准301计算。所示值为安装类型B：自由入口，管道出口的声功率级（入口L<sub>WA</sub>）。

Performance certified is for installation type B: free inlet, ducted outlet. Power rating (kW) does not include transmission losses. Performance ratings do not include the effects of appurtenances (accessories). The A-weighted sound ratings shown have been calculated per AMCA International Standard 301. Values shown are for inlet L<sub>WA</sub> sound power levels for installation type B: free inlet, ducted outlet.

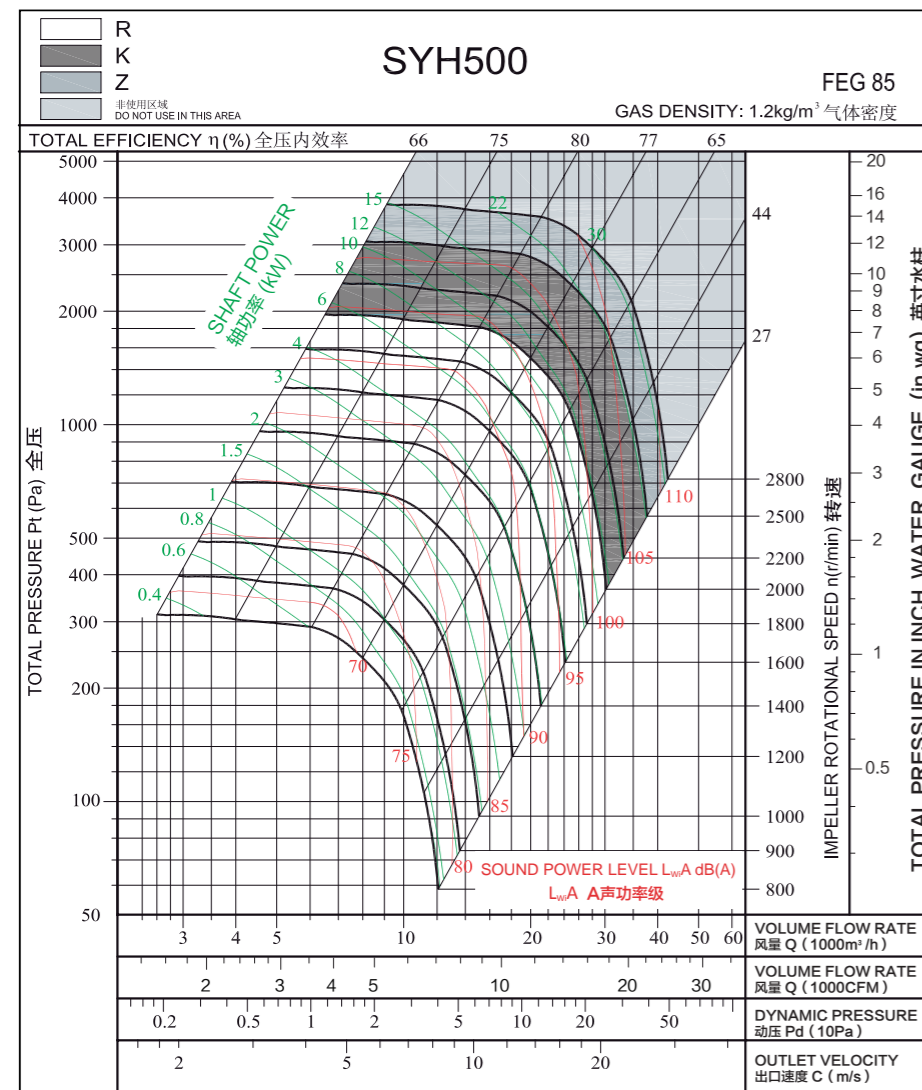

## 性能曲线

## Performance Curve

经认证的性能是B类安装：自由入口，管道出口。功率额定值(kW)不包括传输损失。各项性能额定值不包括附属物(附件)的影响。所示A加权声音性能额定值已按AMCA International标准301计算。所示值为安装类型B：自由入口，管道出口的声功率级（入口L<sub>WA</sub>）。

Performance certified is for installation type B: free inlet, ducted outlet. Power rating (kW) does not include transmission losses. Performance ratings do not include the effects of appurtenances (accessories). The A-weighted sound ratings shown have been calculated per AMCA International Standard 301. Values shown are for inlet L<sub>WA</sub> sound power levels for installation type B: free inlet, ducted outlet.

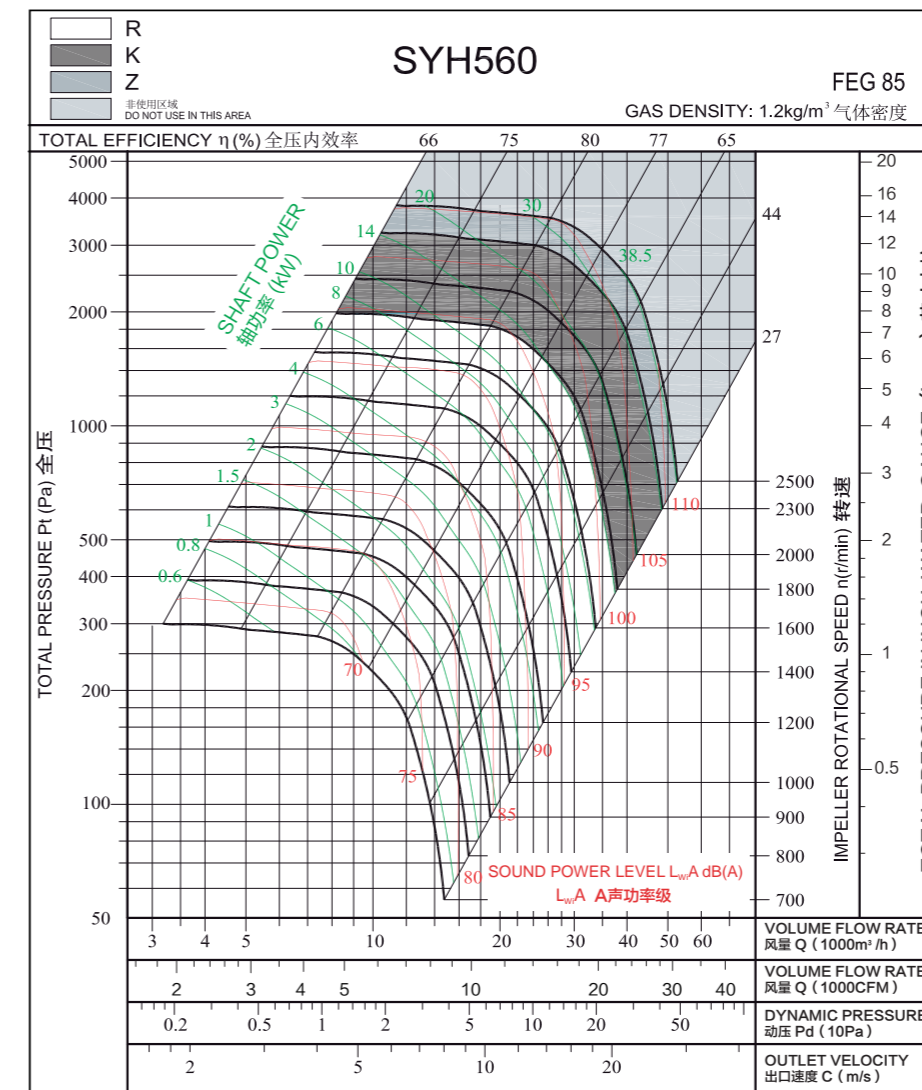

## 技术参数

## Technical Data

Wheel diameter 叶轮直径	D = 630 mm	Fan weight 风机质量	m = 197 kg
Moment of inertia 转动惯量	J = 2.9 kg · m <sup>2</sup>	Speed limit 极限转速	n <sub>max</sub> = 2200 r/min

## 技术参数

## Technical Data

Wheel diameter 叶轮直径	D = 710 mm	Fan weight 风机质量	m = 271kg
Moment of inertia 转动惯量	J = 5.8kg · m <sup>2</sup>	Speed limit 极限转速	n <sub>max</sub> = 2000 r/min

## 性能曲线

## Performance Curve

经认证的性能是B类安装：自由入口，管道出口。功率额定值(kW)不包括传输损失。各项性能额定值不包括附属物(附件)的影响。所示A加权声音性能额定值已按AMCA International标准301计算。所示值为安装类型B：自由入口，管道出口的声功率级（入口L<sub>WA</sub>）。

Performance certified is for installation type B: free inlet, ducted outlet. Power rating (kW) does not include transmission losses. Performance ratings do not include the effects of appurtenances (accessories). The A-weighted sound ratings shown have been calculated per AMCA International Standard 301. Values shown are for inlet L<sub>WA</sub> sound power levels for installation type B: free inlet, ducted outlet.

## 性能曲线

## Performance Curve

经认证的性能是B类安装：自由入口，管道出口。功率额定值(kW)不包括传输损失。各项性能额定值不包括附属物(附件)的影响。所示A加权声音性能额定值已按AMCA International标准301计算。所示值为安装类型B：自由入口，管道出口的声功率级（入口L<sub>WA</sub>）。

Performance certified is for installation type B: free inlet, ducted outlet. Power rating (kW) does not include transmission losses. Performance ratings do not include the effects of appurtenances (accessories). The A-weighted sound ratings shown have been calculated per AMCA International Standard 301. Values shown are for inlet L<sub>WA</sub> sound power levels for installation type B: free inlet, ducted outlet.

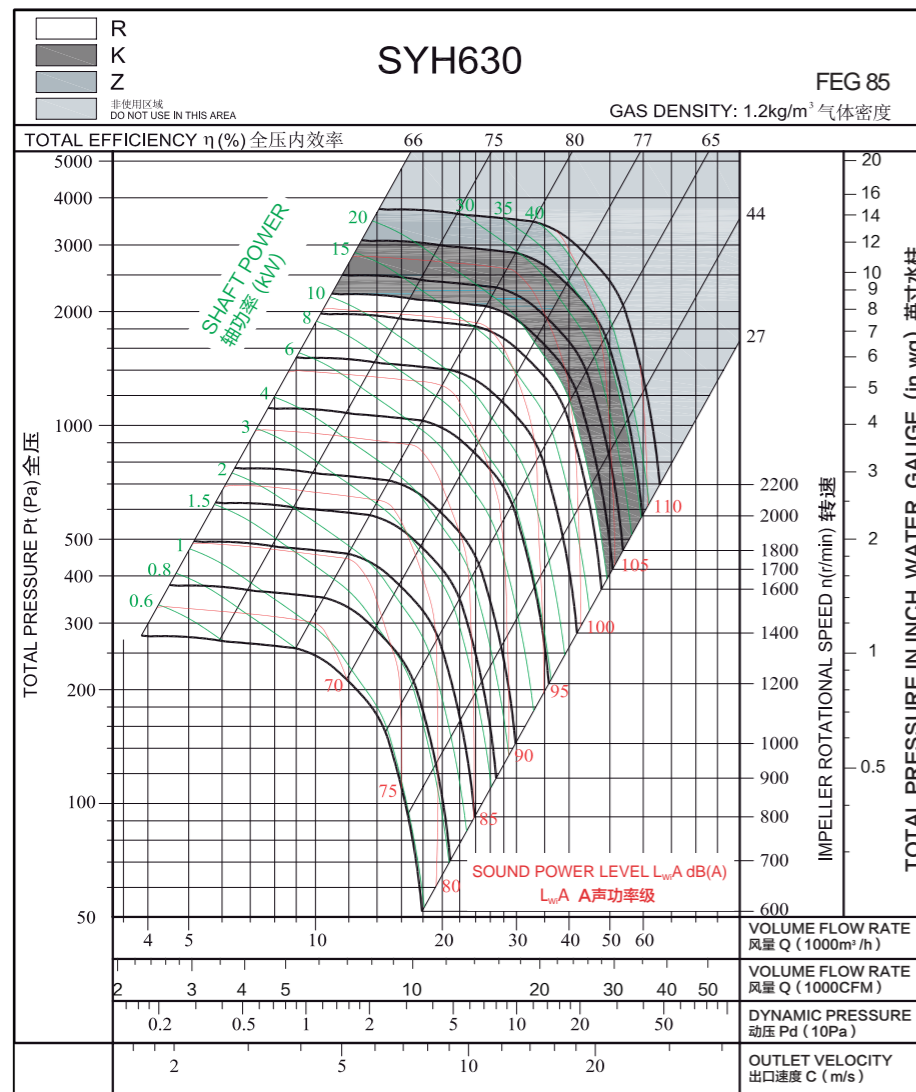

Measured in installation B according to AMCA Standard 210:

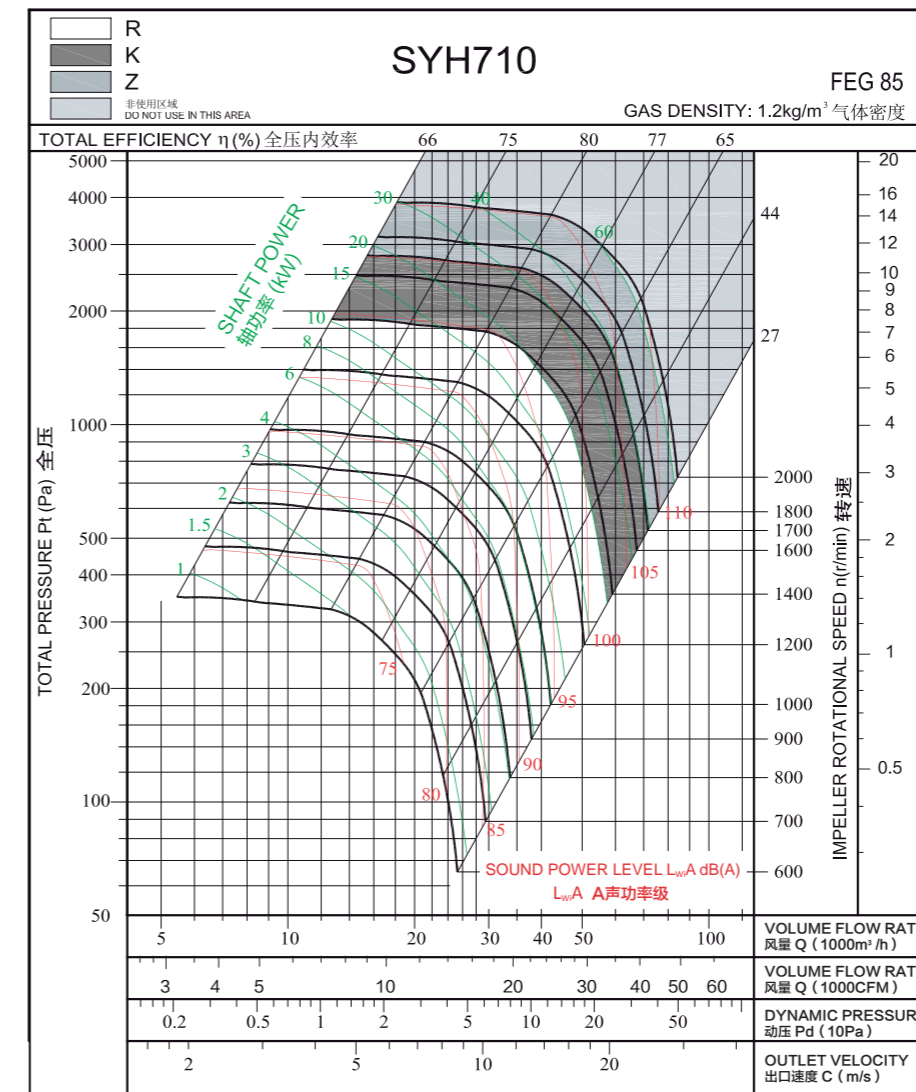
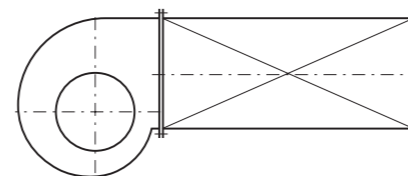

Measured in installation B according to AMCA Standard 210:

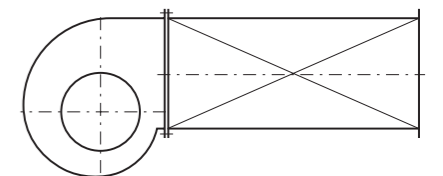



## 技术参数

## Technical Data

Wheel diameter 叶轮直径	D = 800 mm	Fan weight 风机质量	m = 300 kg
Moment of inertia 转动惯量	J = 10.35 kg·m <sup>2</sup>	Speed limit 极限转速	n <sub>max</sub> = 1600 r/min

## 技术参数

## Technical Data

Wheel diameter 叶轮直径	D = 900 mm	Fan weight 风机质量	m = 481.5kg
Moment of inertia 转动惯量	J = 15.5kgm <sup>2</sup>	Speed limit 极限转速	n <sub>max</sub> = 1400r/min

## 性能曲线

## Performance Curve

经认证的性能是B类安装：自由入口，管道出口。功率额定值(kW)不包括传输损失。各项性能额定值不包括附属物(附件)的影响。所示A加权声音性能额定值已按AMCA International标准301计算。所示值为安装类型B：自由入口，管道出口的声功率级（入口L<sub>wA</sub>）。

Performance certified is for installation type B: free inlet, ducted outlet. Power rating (kW) does not include transmission losses. Performance ratings do not include the effects of appurtenances (accessories). The A-weighted sound ratings shown have been calculated per AMCA International Standard 301. Values shown are for inlet L<sub>wA</sub> sound power levels for installation type B: free inlet, ducted outlet.

## 性能曲线

## Performance Curve

经认证的性能是B类安装：自由入口，管道出口。功率额定值(kW)不包括传输损失。各项性能额定值不包括附属物(附件)的影响。所示A加权声音性能额定值已按AMCA International标准301计算。所示值为安装类型B：自由入口，管道出口的声功率级（入口L<sub>wA</sub>）。

Performance certified is for installation type B: free inlet, ducted outlet. Power rating (kW) does not include transmission losses. Performance ratings do not include the effects of appurtenances (accessories). The A-weighted sound ratings shown have been calculated per AMCA International Standard 301. Values shown are for inlet L<sub>wA</sub> sound power levels for installation type B: free inlet, ducted outlet.

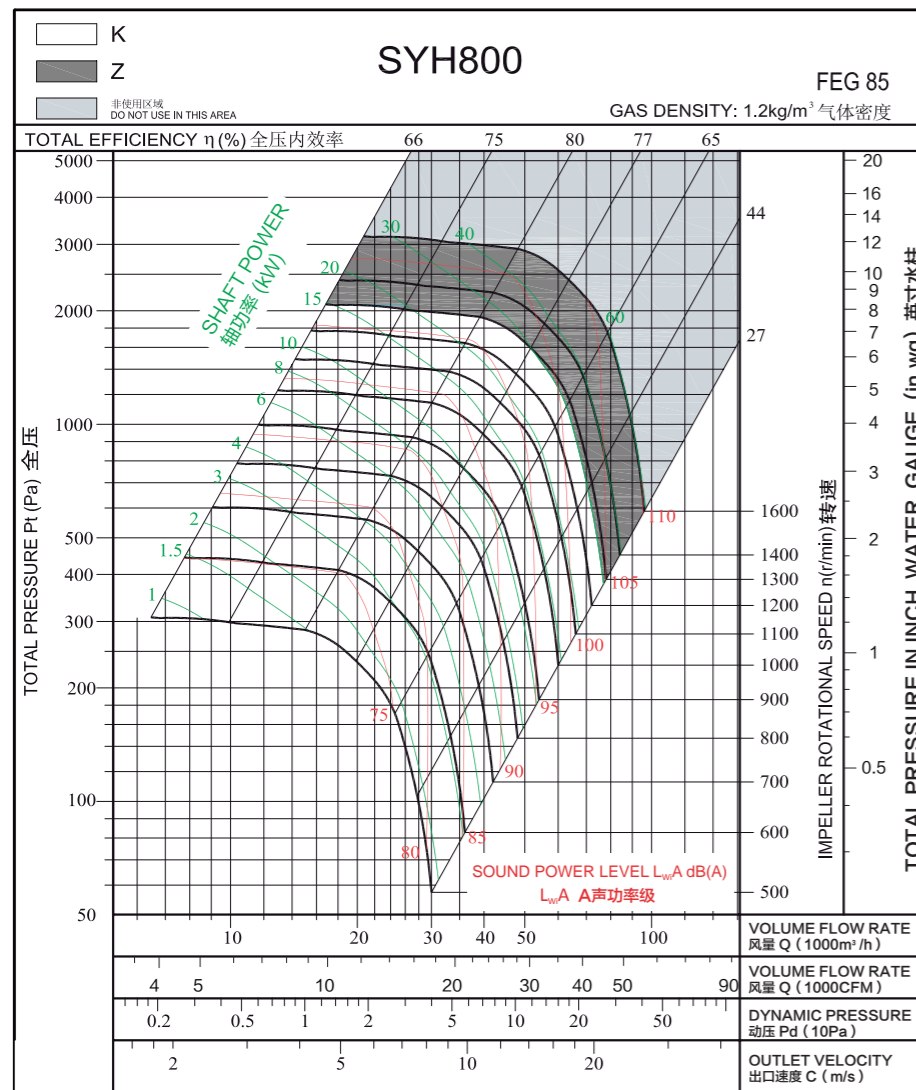

Measured in installation B according to AMCA Standard 210:

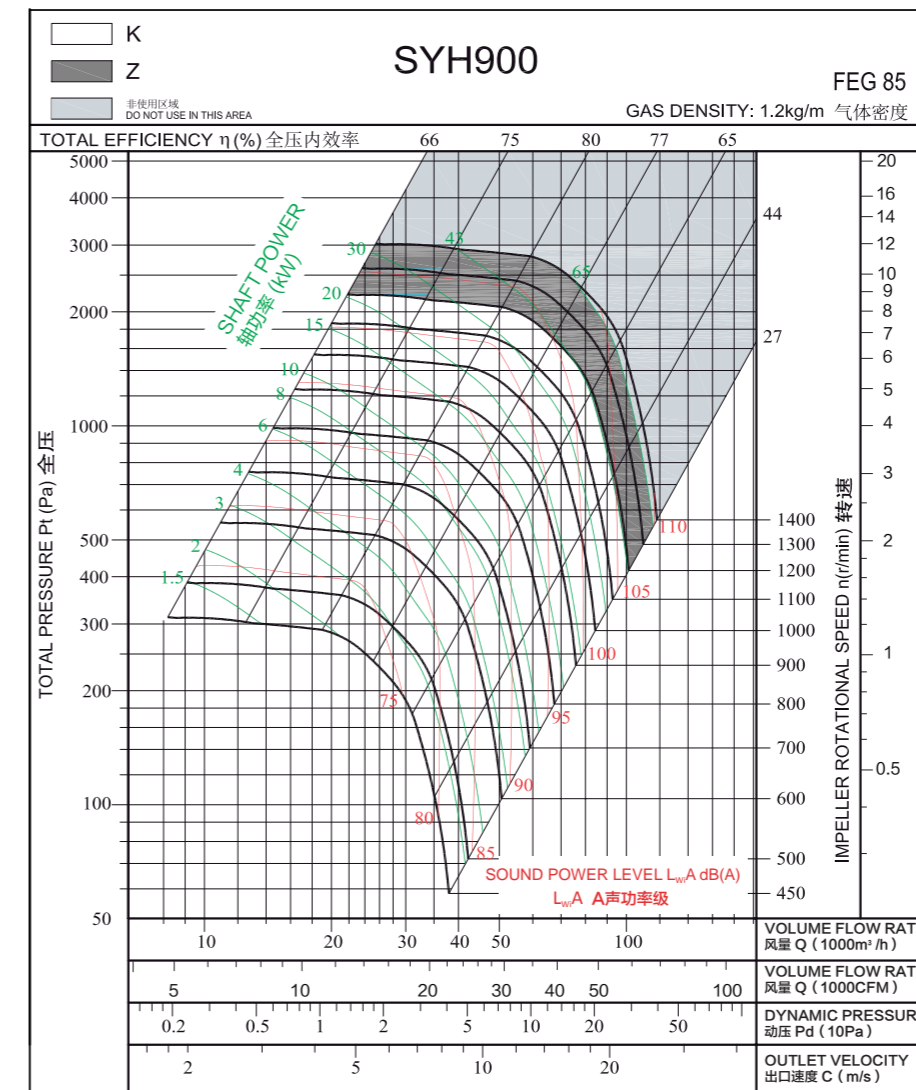
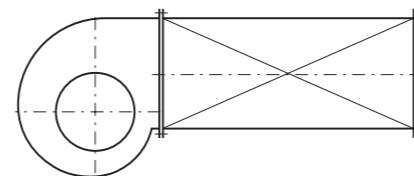

Measured in installation B according to AMCA Standard 210:

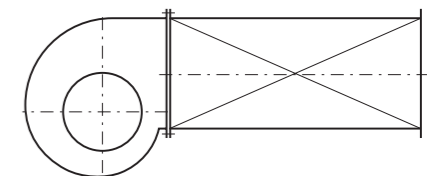

## 技术参数

## Technical Data

Wheel diameter 叶轮直径	D = 1000 mm	Fan weight 风机质量	m = 530 kg
Moment of inertia 转动惯量	J = 26.7 kg · m <sup>2</sup>	Speed limit 极限转速	n <sub>max</sub> = 1300r/min

## 技术参数

## Technical Data

Wheel diameter 叶轮直径	D = 1120 mm	Fan weight 风机质量	m = 820kg
Moment of inertia 转动惯量	J =15.5kg·m <sup>2</sup>	Speed limit 极限转速	n <sub>max</sub> = 1450r/min

## 性能曲线

## Performance Curve

经认证的性能是B类安装：自由入口，管道出口。功率额定值(kW)不包括传输损失。各项性能额定值不包括附属物(附件)的影响。所示A加权声音性能额定值已按AMCA International标准301计算。所示值为安装类型B：自由入口，管道出口的声功率级（入口L<sub>WA</sub>）。

Performance certified is for installation type B: free inlet, ducted outlet. Power rating (kW) does not include transmission losses. Performance ratings do not include the effects of appurtenances (accessories). The A-weighted sound ratings shown have been calculated per AMCA International Standard 301. Values shown are for inlet L<sub>WA</sub> sound power levels for installation type B: free inlet, ducted outlet.

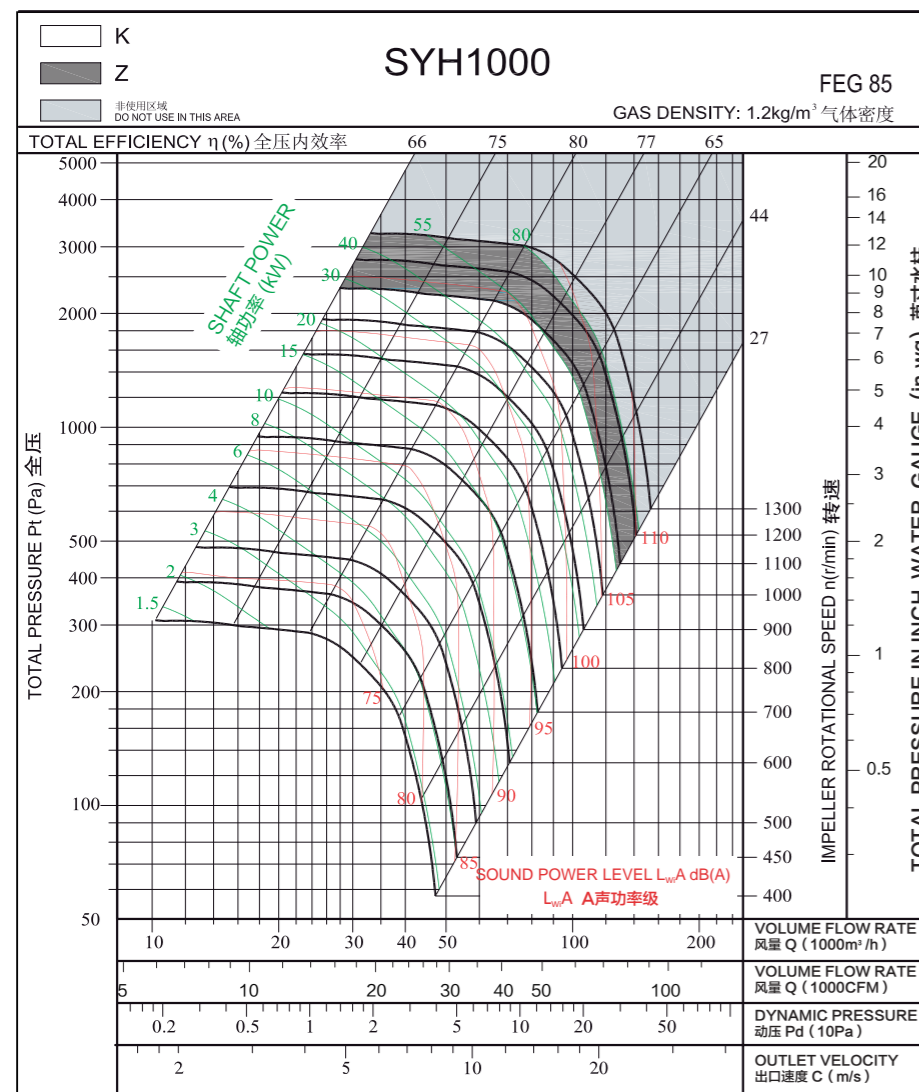

Measured in installation B according to AMCA Standard 210:

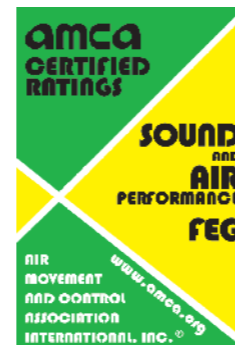
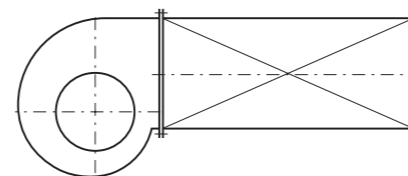

## 性能曲线

## Performance Curve

经认证的性能是B类安装：自由入口，管道出口。功率额定值(kW)不包括传输损失。各项性能额定值不包括附属物(附件)的影响。所示A加权声音性能额定值已按AMCA International标准301计算。所示值为安装类型B：自由入口，管道出口的声功率级（入口L<sub>WA</sub>）。

Performance certified is for installation type B: free inlet, ducted outlet. Power rating (kW) does not include transmission losses. Performance ratings do not include the effects of appurtenances (accessories). The A-weighted sound ratings shown have been calculated per AMCA International Standard 301. Values shown are for inlet L<sub>WA</sub> sound power levels for installation type B: free inlet, ducted outlet.

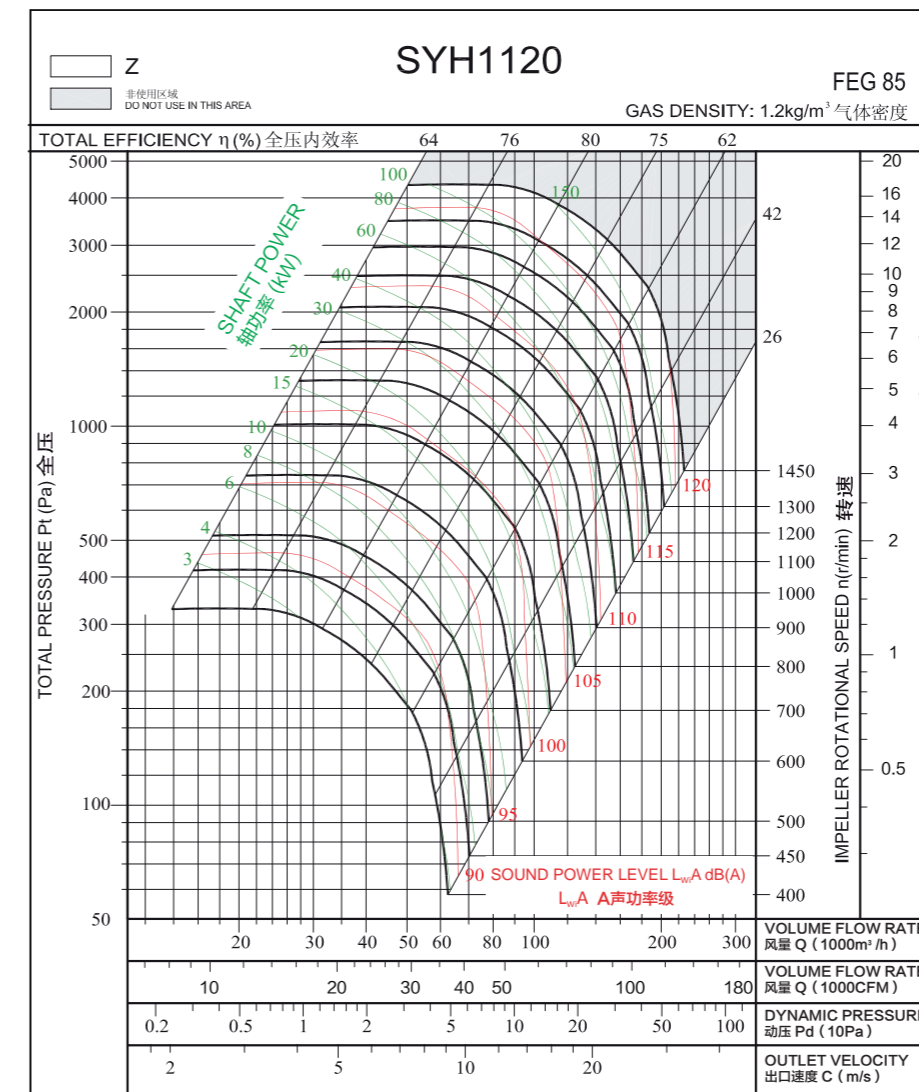

Measured in installation B according to AMCA Standard 210:

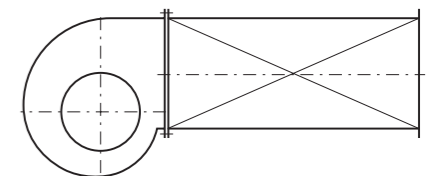

### 技术参数

### Technical Data

Wheel diameter 叶轮直径	D = 1250 mm	Fan weight 风机质量	m = 1140 kg
Moment of inertia 转动惯量	J = 80.7 kg·m <sup>2</sup>	Speed limit 极限转速	n <sub>max</sub> = 1300r/min

### 技术参数

### Technical Data

Wheel diameter 叶轮直径	D = 1400 mm	Fan weight 风机质量	m = 1460kg
Moment of inertia 转动惯量	J =156.9kg·m <sup>2</sup>	Speed limit 极限转速	n <sub>max</sub> = 1150r/min

### 性能曲线

### Performance Curve

经认证的性能是B类安装：自由入口，管道出口。功率额定值(kW)不包括传输损失。各项性能额定值不包括附属物(附件)的影响。所示A加权声音性能额定值已按AMCA International标准301计算。所示值为安装类型B：自由入口，管道出口的声功率级（入口L<sub>WA</sub>）。

Performance certified is for installation type B: free inlet, ducted outlet. Power rating (kW) does not include transmission losses. Performance ratings do not include the effects of appurtenances (accessories). The A-weighted sound ratings shown have been calculated per AMCA International Standard 301. Values shown are for inlet L<sub>WA</sub> sound power levels for installation type B: free inlet, ducted outlet.

### 性能曲线

### Performance Curve

经认证的性能是B类安装：自由入口，管道出口。功率额定值(kW)不包括传输损失。各项性能额定值不包括附属物(附件)的影响。所示A加权声音性能额定值已按AMCA International标准301计算。所示值为安装类型B：自由入口，管道出口的声功率级（入口L<sub>WA</sub>）。

Performance certified is for installation type B: free inlet, ducted outlet. Power rating (kW) does not include transmission losses. Performance ratings do not include the effects of appurtenances (accessories). The A-weighted sound ratings shown have been calculated per AMCA International Standard 301. Values shown are for inlet L<sub>WA</sub> sound power levels for installation type B: free inlet, ducted outlet.

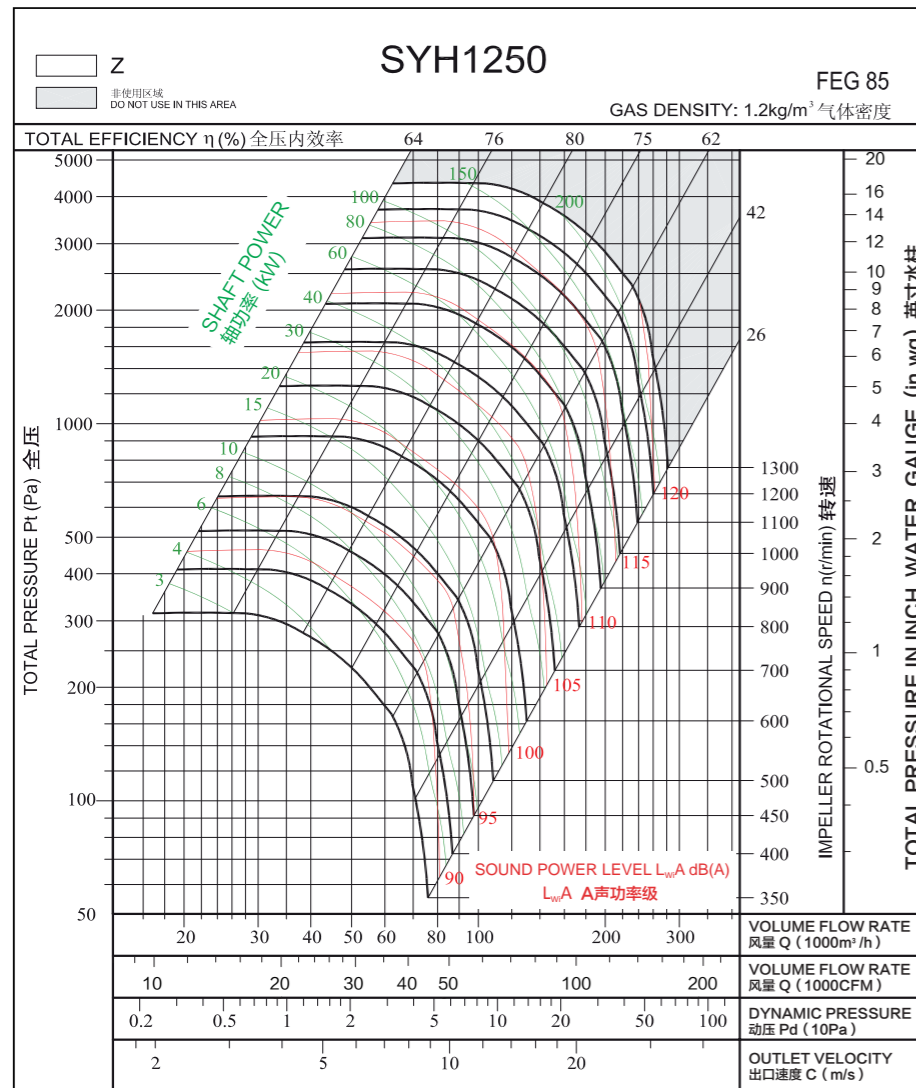

Measured in installation B according to AMCA Standard 210:

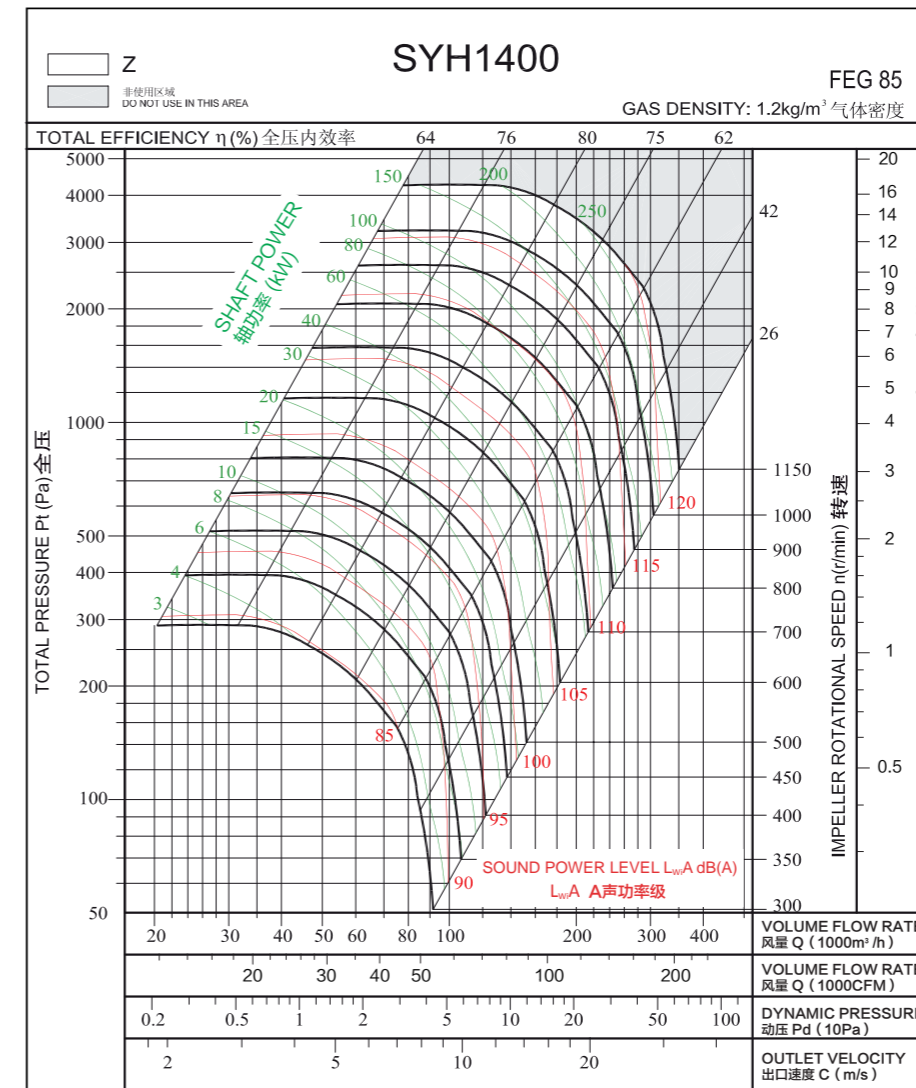
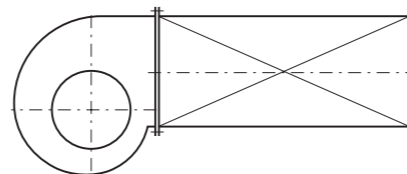

Measured in installation B according to AMCA Standard 210:

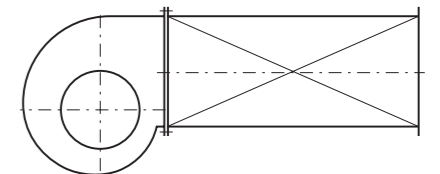



## 技术参数

## Technical Data

Wheel diameter 叶轮直径	D = 1600 mm	Fan weight 风机质量	m = 1820 kg
Moment of inertia 转动惯量	J = 260.8 kg·m <sup>2</sup>	Speed limit 极限转速	n <sub>max</sub> = 1000r/min

## 性能曲线

## Performance Curve

经认证的性能是B类安装：自由入口，管道出口。功率额定值(kW)不包括传输损失。各项性能额定值不包括附属物(附件)的影响。所示A加权声音性能额定值已按AMCA International标准301计算。所示值为安装类型B：自由入口，管道出口的声功率级（入口L<sub>wA</sub>）。

Performance certified is for installation type B: free inlet, ducted outlet. Power rating (kW) does not include transmission losses. Performance ratings do not include the effects of appurtenances (accessories). The A-weighted sound ratings shown have been calculated per AMCA International Standard 301. Values shown are for inlet L<sub>wA</sub> sound power levels for installation type B: free inlet, ducted outlet.

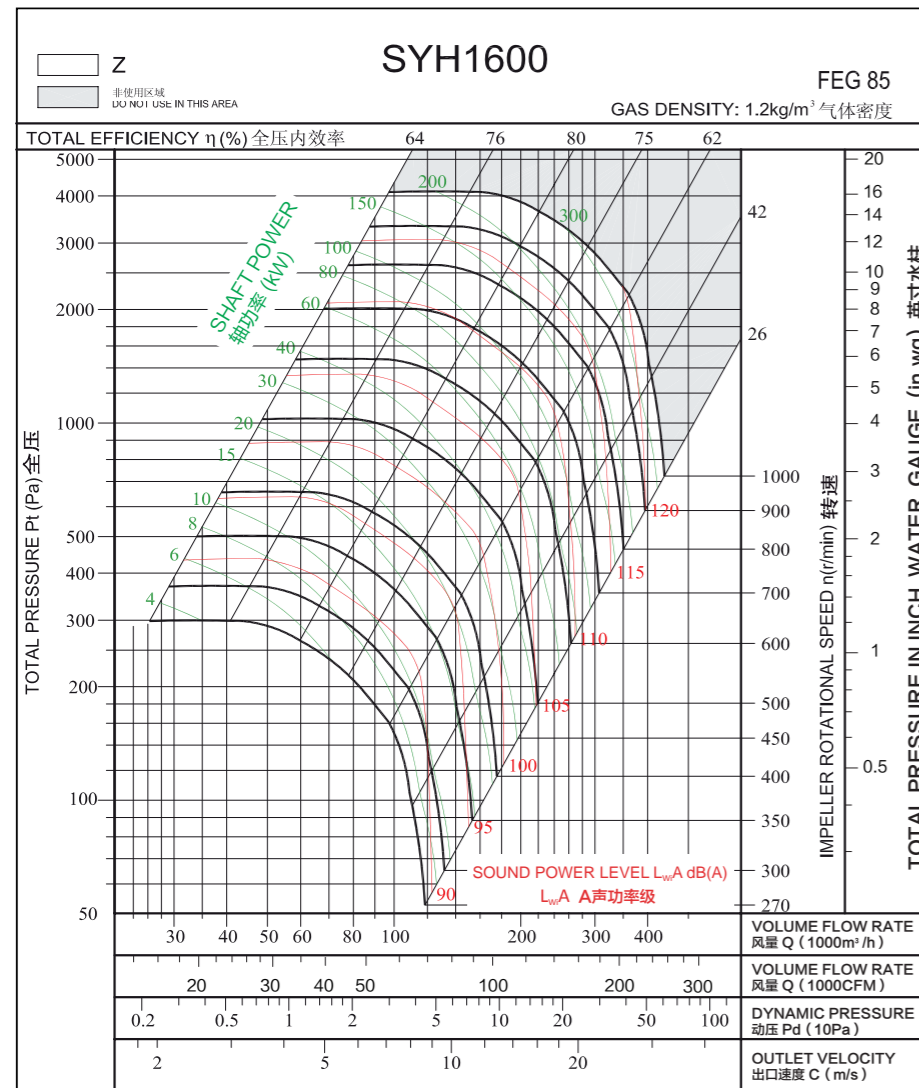

Measured in installation B according to AMCA Standard 210:

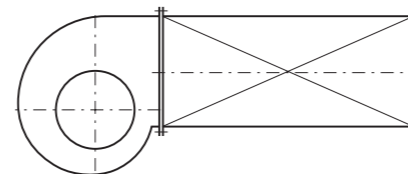

## 出口法兰

## Outlet Flange



图2 ( Fig 2)

单位: mm

Modle	280	315	355	400	450	500	560	630	710	800	900	1000
Dim A	361	404	453	507	569	638	715	801	898	1007	1130	1267
Dim B	417	460	509	563	625	694	771	857	954	1063	1186	1323
Dim C	195.5	217	241.5	-	-	-	-	-	-	-	-	-
Dim D	-	-	-	-	-	-	-	-	200	250	300	350
Dim E	-	-	-	200	200	250	250	300	400	500	600	700
Dim F	-	-	-	168.5	199.5	209	207.5	265.5	264	268.5	280	298.5

## 出口法兰

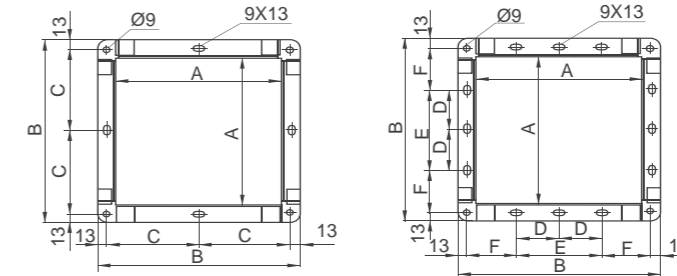
## Outlet Flange



图2 ( Fig 2)

单位: mm

Modle	1120	1250	1400	1600
Dim A	1426	1588	1776	2027
Dim B	1349	1494	1687	1900
Dim C	1526	1688	1876	2127
Dim D	1449	1594	1787	2000
Dim E	1476	1638	1826	2077
Dim F	1399	1544	1737	1950
n-øD	16-ø15	16-ø15	26-ø15	24-ø15

SYH-R

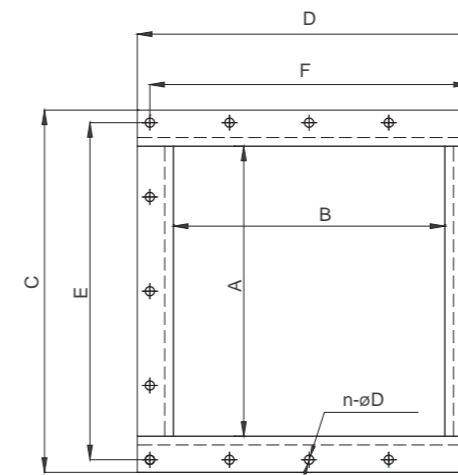
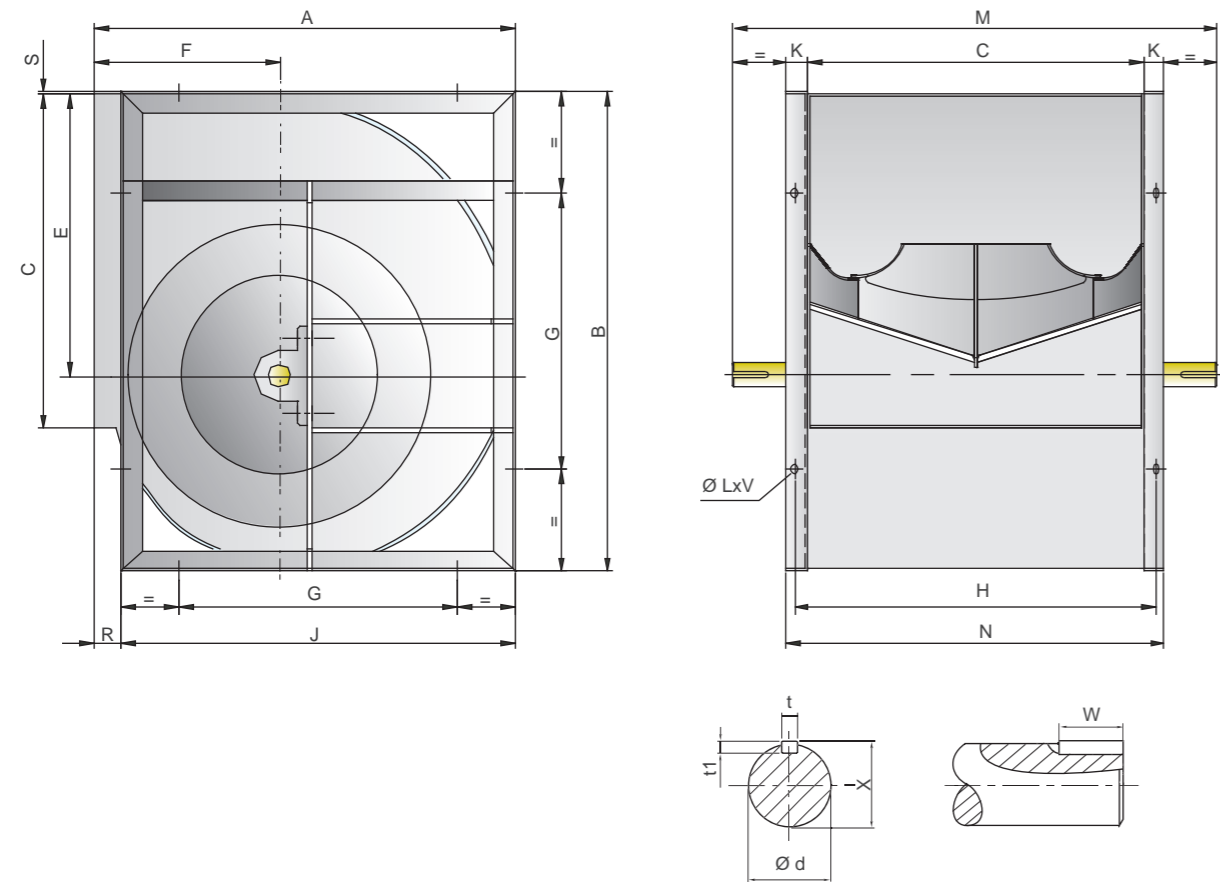

单位: mm

Model Dim	A	B	C	E	F	G	H	J	K	M	N	R	S	t	t1	W	X	φd	LxV
280	466	518	361	302	215	280	391	432	30	575	421	34	5	8	7	50	28	25	13x18
315	518	578	404	340	236	280	434	480	30	640	464	38	3	8	7	60	28	25	13x18
355	578	655	453	383	261	355	493	548	40	700	533	30	6	8	7	60	33	30	13x18
400	651	736	507	432	290	355	547	613	40	760	587	38	4.5	8	7	60	33	30	13x18
450	726	827	569	486	322	530	609	681	40	845	649	45	5	10	8	70	38	35	13x18
500	800	918	638	538	352	530	678	750	40	915	718	50	5	10	8	70	38	35	13x18
560	893	1030	715	602	390	530	765	845	50	1000	815	48	8	12	8	70	43	40	13x18
630	999	1157	801	679	434	530	851	946	50	1090	901	53	7	14	9	70	48.5	45	13x18
710	1121	1303	898	765	485	630	948	1058	50	1255	998	63	7	14	9	90	53.5	50	17x22

SYH-K(Z)

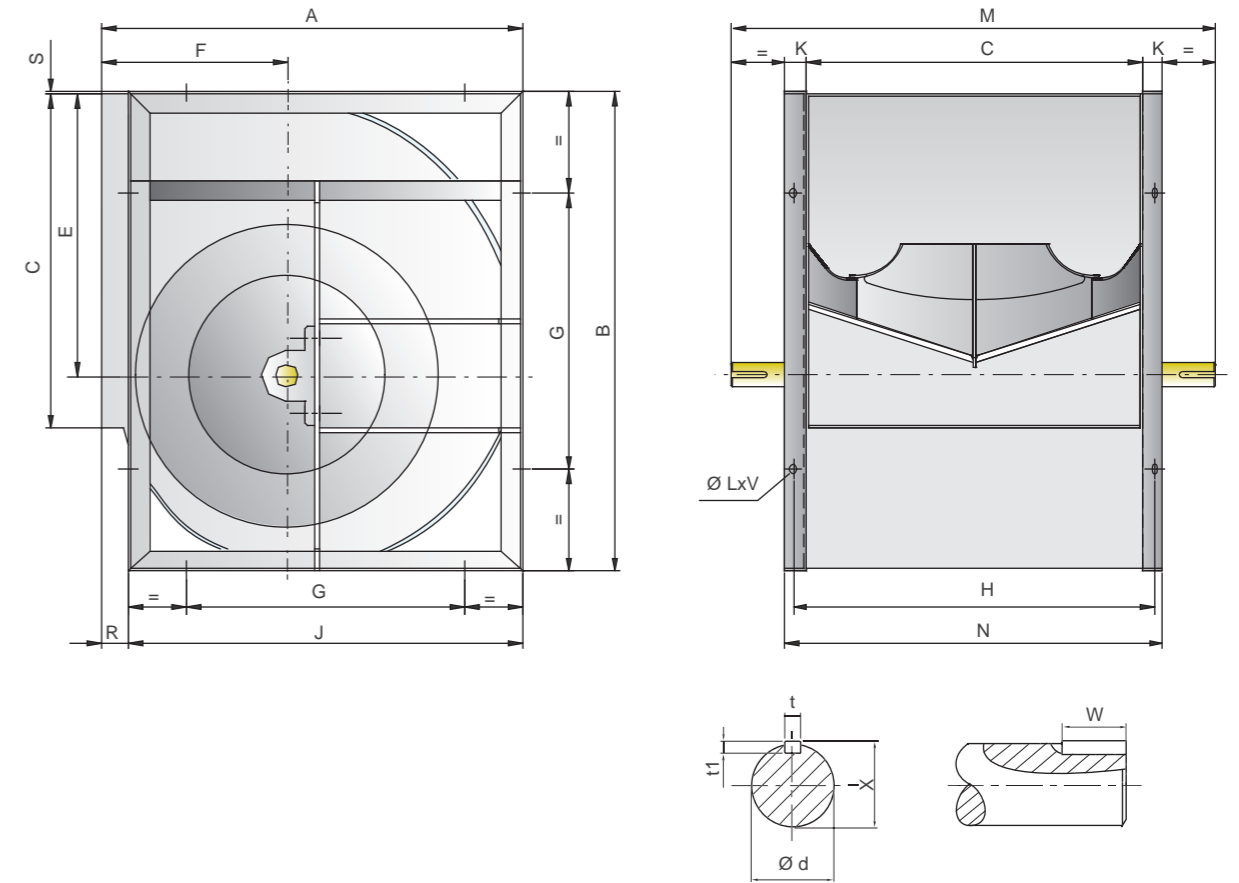

单位: mm

Model Dim	A	B	C	E	F	G	H	J	K	M	N	R	S	t	t1	W	X	φd	LxV
280	466	518	361	302	215	280	391	432	30	600	421	34	5	8	7	60	33	30	13x18
315	518	578	404	340	236	280	434	480	30	665	464	38	3	8	7	70	33	30	13x18
355	578	655	453	383	261	355	493	548	40	725	533	30	6	10	8	70	38	35	13x18
400	651	736	507	432	290	355	547	613	40	790	587	38	4.5	10	8	70	38	35	13x18
450	726	827	569	486	322	530	609	681	40	890	649	45	4.5	12	8	90	43	40	13x18
500	800	918	638	538	352	530	678	750	40	960	718	50	5	12	8	90	43	40	13x18
560	893	1030	715	603	390	530	765	845	50	1070	815	48	8	14	9	90	53.5	50	13x18
630	899	1157	801	679	434	530	851	946	50	1155	901	53	7	14	9	90	53.5	50	13x18
710	1121	1303	898	765	485	630	948	1058	50	1293	998	63	7	18	11	90	64	60	17x22
800	1250	1468	1007	862	535	710	1057	1181	50	1450	1107	69	7	18	11	90	64	60	17x22
900	1408	1648	1130	971	604	800	1180	1319	60	1570	1250	89	7	18	11	100	69	65	17x22
1000	1541	1810	1267	1066	657	900	1317	1462	60	1700	1387	79	9	18	11	100	69	65	17x22

**SYH-K(Z)**

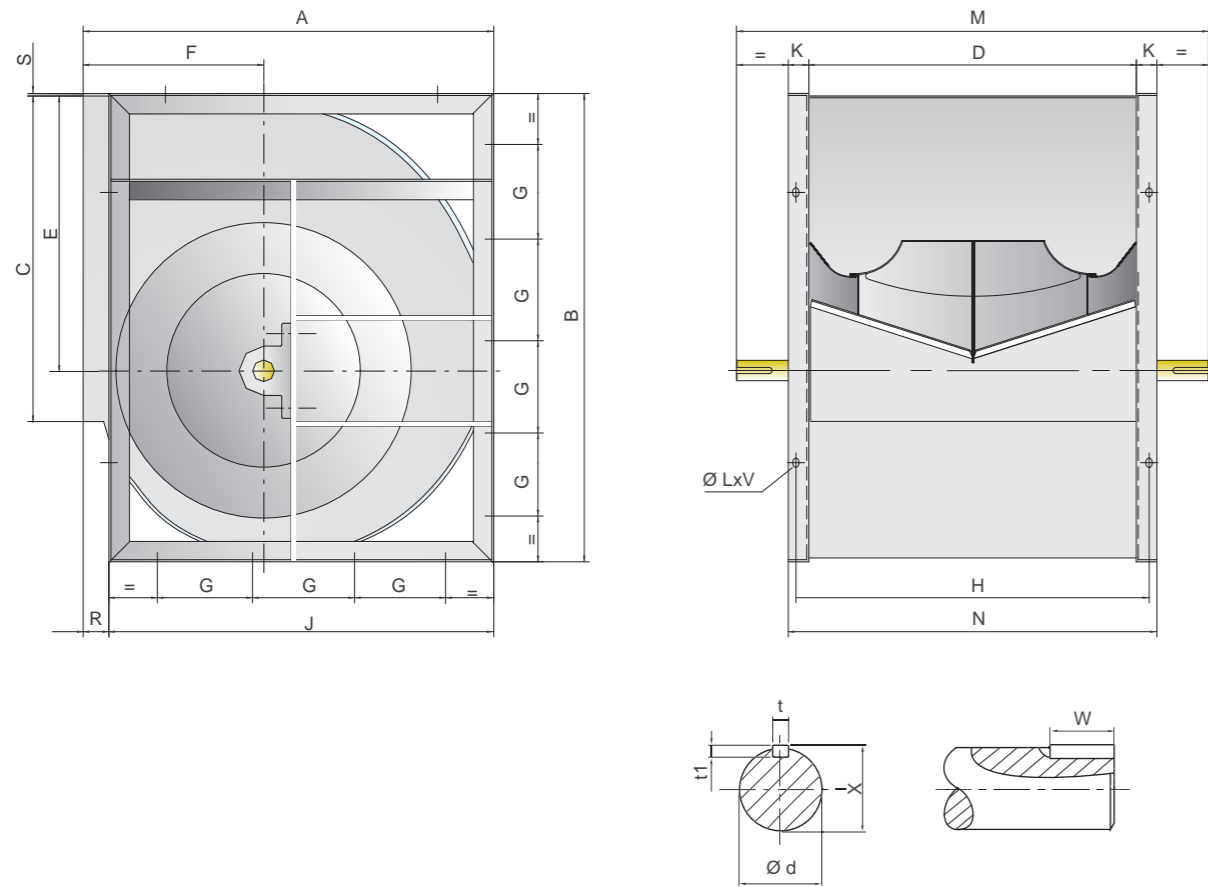

单位: mm

Model Dim	A	B	C	D	E	F	G	H	J	K	M	N	R	S	t	t1	W	X	$\phi d$	LxV
1120	1748	2033	1423	1346	1194	758	400	1406	1630	60	1960	1466	118	8	20	12	140	79.5	75	17x22
1250	1950	2270	1588	1494	1333	840	450	1574	1825	75	2115	1644	125	12	22	14	140	85	80	17x22
1400	2160	2535	1774	1685	1492	920	500	1765	2050	75	2250	1835	110	10	22	14	140	90	85	17x22
1600	2468	2897	2027	1900	1705	1050	570	1975	2345	75	2650	2050	123	11	25	14	140	100	95	17x22

**SYH-R(K)2**

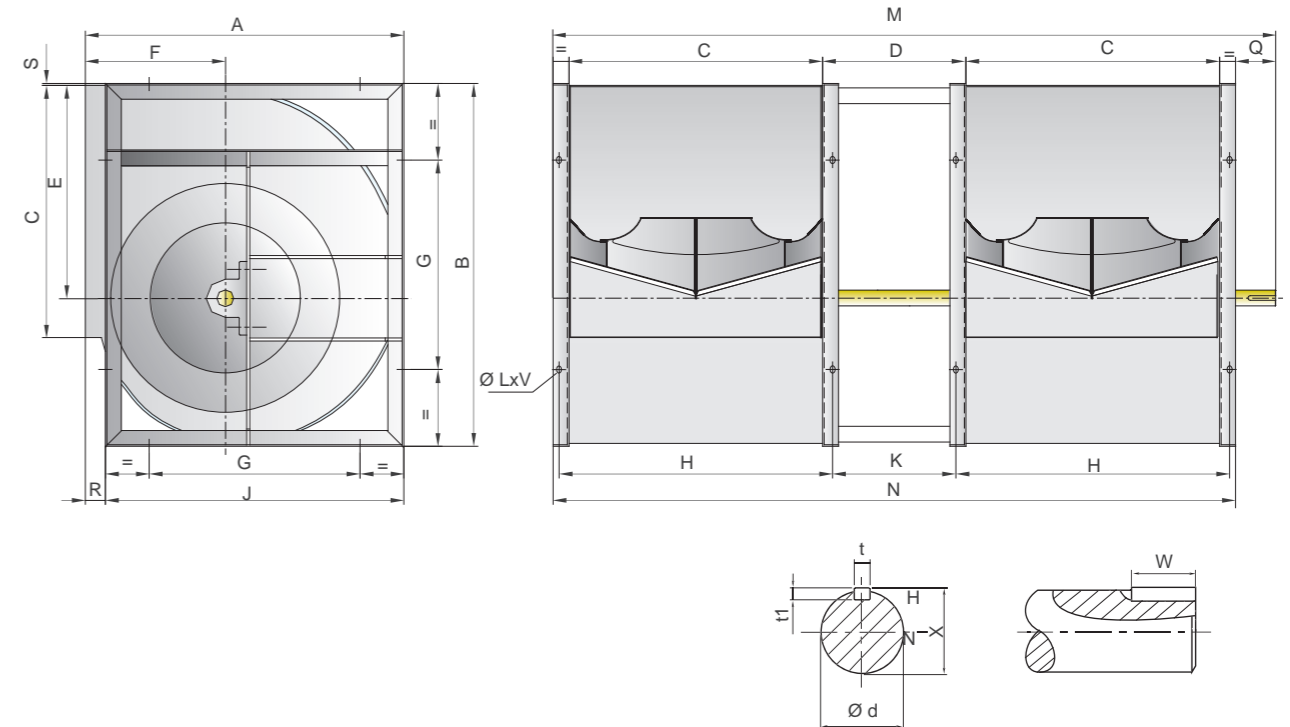

单位: mm

**SYH-R2**

Model Dim	A	B	C	D	E	F	G	H	J	K	M	N	Q	R	S	t	t1	W	X	$\phi d$	LxV
280	466	518	361	280	302	214	280	391	432	250	1165	1062	103	34	5	8	7	60	28	25	13x18
315	518	578	404	315	340	236	280	434	480	285	1286	1183	103	38	3	8	7	60	33	30	13x18
355	578	654	453	355	383	260	355	493	548	315	1442	1340	101	30	6	10	8	60	38	35	13x18
400	65	736	507	400	432	290	355	547	612	360	1610	1494	116	38	4.5	12	8	60	43	40	13x18
450	726	827	569	450	486	322	530	609	681	410	1782	1668	114	45	5	12	8	70	43	40	13x18
500	800	918	638	500	538	352	530	678	750	460	1165	1062	103	50	5	14	9	70	48.5	45	13x18

**SYH-K2**

单位: mm

Model Dim	A	B	C	D	E	F	G	H	J	K	M	N	Q	R	S	t	t1	W	X	$\phi d$	LxV
355	578	654	453	355	383	260	355	493	548	315	1442	1341	101	30	6	12	8	70	43	40	13x18
400	650	736	507	400	432	290	355	547	612	360	1610	1494	116	38	4.5	14	9	70	48.5	45	13x18
450	726	827	569	450	486	322	530	609	681	410	1795	1668	127	45	5	14	9	90	48.5	45	13x18
500	800	918	638	500	538	352	530	678	750	460	1977	1856	121	50	5	14	9	90	53.5	50	13x18
560	893	1030	715	560	602	390	530	765	845	510	2218	2090	128	48	8	14	9	90	53.5	50	13x18



**SYH-R(K)**

		0°				90°				180°					
左旋 LG Left Hand															
右旋 RD Right Hand															
型号 Model	电机 机座型号 Motor Frame Size	A			B			C	A			B			C
		R型	K型		R型	K型			R型	K型					
280	71	940	575	600	568	940	575	600	516	940	575	600	568		
	80	940	575	600	568	940	575	600	516	940	575	600	568		
	90	940	575	600	568	940	575	600	516	940	575	600	568		
	100	940	575	600	568	940	575	600	516	940	575	600	568		
	112	940	575	600	568	940	575	600	516	940	575	600	568		
	132	940	575	600	568	940	575	600	516	940	575	600	568		
315	71	1040	640	665	628	1040	640	665	568	1040	640	665	628		
	80	1040	640	665	628	1040	640	665	568	1040	640	665	628		
	90	1040	640	665	628	1040	640	665	568	1040	640	665	628		
	100	1040	640	665	628	1040	640	665	568	1040	640	665	628		
	112	1040	640	665	628	1040	640	665	568	1040	640	665	628		
	132	1040	640	665	628	1040	640	665	568	1040	640	665	628		
355	80	1110	700	725	705	1110	700	725	628	1110	700	725	705		
	90	1110	700	725	705	1110	700	725	628	1110	700	725	705		
	100	1110	700	725	705	1110	700	725	628	1110	700	725	705		
	112	1110	700	725	705	1110	700	725	628	1110	700	725	705		
	132	1110	700	725	705	1110	700	725	628	1110	700	725	705		
400	180	1250	700	725	705	1250	700	725	628	1250	700	725	705		
	90	1250	760	790	786	1250	760	790	701	1250	760	790	786		
	100	1250	760	790	786	1250	760	790	701	1250	760	790	786		
	112	1250	760	790	786	1250	760	790	701	1250	760	790	786		
	132	1250	760	790	786	1250	760	790	701	1250	760	790	786		
	160	1250	760	790	786	1250	760	790	701	1250	760	790	786		
450	90	1340	845	890	877	1340	845	890	776	1340	845	890	877		
	100	1340	845	890	877	1340	845	890	776	1340	845	890	877		
	112	1340	845	890	877	1340	845	890	776	1340	845	890	877		
	132	1340	845	890	877	1340	845	890	776	1340	845	890	877		
	160	1340	845	890	877	1340	845	890	776	1340	845	890	877		
	180	1340	845	890	877	1340	845	890	776	1340	845	890	877		
	200	1340	845	890	877	1340	845	890	776	1340	845	890	877		
500	90	1420	915	960	981	1420	915	960	863	1420	915	960	981		
	100	1420	915	960	981	1420	915	960	863	1420	915	960	981		
	112	1420	915	960	981	1420	915	960	863	1420	915	960	981		
	132	1420	915	960	981	1420	915	960	863	1420	915	960	981		
	160	1420	915	960	981	1420	915	960	863	1420	915	960	981		
	180	1420	915	960	981	1420	915	960	863	1420	915	960	981		

**SYH-R(K)**

		0°				90°				180°					
左旋 LG Left Hand															
右旋 RD Right Hand															
型号 Model	电机 机座型号 Motor Frame Size	A			B			C	A			B			C
		R型	K型		R型	K型			R型	K型					
560	90	1580	1000	1070	1093	1580	1000	1070	956	1580	1000	1070	1093		
	100	1580	1000	1070	1093	1580	1000	1070	956	1580	1000	1070	1093		
	112	1580	1000	1070	1093	1580	1000	1070	956	1580	1000	1070	1093		
	132	1580	1000	1070	1093	1580	1000	1070	956	1580	1000	1070	1093		
	160	1580	1000	1070	1093	1580	1000	1070	956	1580	1000	1070	1093		
	180	1580	1000	1070	1093	1580	1000	1070	956	1580	1000	1070	1093		
	200	1580	1000	1070	1093	1580	1000	1070	956	1580	1000	1070	1093		
630	100	1770	1090	1155	1220	1770	1090	1155	1062	1770	1090	1155	1220		
	112	1770	1090	1155	1220	1770	1090	1155	1062	1770	1090	1155	1220		
	132	1770	1090	1155	1220	1770	1090	1155	1062	1770	1090	1155	1220		
	160	1770	1090	1155	1220	1770	1090	1155	1062	1770	1090	1155	1220		
	180	1770	1090	1155	1220	1770	1090	1155	1062	1770	1090	1155	1220		
	200	1770	1090	1155	1220	1770	1090	1155	1062	1770	1090	1155	1220		
710	112	1950	1255	1290	1366	1950	1255	1290	1184	1950	1255	1290	1366		
	132	1950	1255	1290	1366	1950	1255	1290	1184	1950	1255	1290	1366		
	160	1950	1255	1290	1366	1950	1255	1290	1184	1950	1255	1290	1366		
	180	1950	1255	1290	1366	1950	1255	1290	1184	1950	1255	1290	1366		
	200	1950	1255	1290	1366	1950	1255	1290	1184	1950	1255	1290	1366		
	225	1950	1255	1290	1366	1950	1255	1290	1184	1950	1255	1290	1366		
800	132	2130	\	1450	1548	2130	\	1450	1330	2130	\	1450	1548		
	160	2130	\	1450	1548	2130	\	1450	1330	2130	\	1450	1548		
	180	2130	\	1450	1548	2130	\	1450	1330	2130	\	1450	1548		
	200	2130	\	1450	1548	2130	\	1450	1330	2130	\	1450	1548		
	225	2130	\	1450	1548	2130	\	1450	1330	2130	\	1450	1548		
	250	2130	\	1450	1548	2130	\	1450	1330	2130	\	1450	1548		
	280	2130	\	1450	1548	2130	\	1450	1330	2130	\	1450	1548		
900	132	2450	\	1570	1748	2450	\	1570	1508	2450	\	1570	1748		
	160	2450	\	1570	1748	2450	\	1570	1508	2450	\	1570	1748		
	180	2450	\	1570	1748	2450	\	1570	1508	2450	\	1570	1748		
	200	2450	\	1570	1748	2450	\	1570	1508	2450	\	1570	1748		
	225	2450	\	1570	1748	2450	\	1570	1508	2450	\	1570	1748		
	250	2450	\	1570	1748	2450	\	1570	1508	2450	\	1570	1748		
	280	2450	\	1570	1748	2450	\	1570	1508	2450	\	1570	1748		
1000	132	2650	\	1700	1910	2650	\	1700	1641	2650	\	1700	1910		
	160	2650	\	1700	1910	2650	\	1700	1641	2650	\	1700	1910		
	180	2650	\	1700	1910	2650	\	1700	1641	2650	\	1700	1910		
	200	2650	\	1700	1910	2650	\	1700	1641	2650	\	1700	1910		
	225	2650	\	1700	1910	2650	\	1700	1641	2650	\	1700	1910		
	250	2650	\	1700	1910	2650	\	1700	1641	2650	\	1700	1910		
	280	2650	\	1700	1910	2650	\	1700	1641	2650	\	1700	1910		

## SYH-R(K)

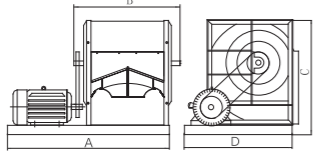
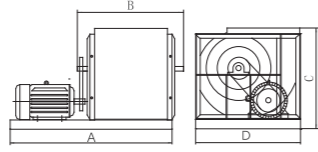
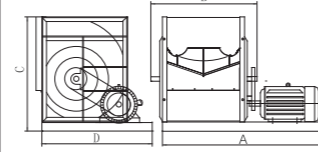
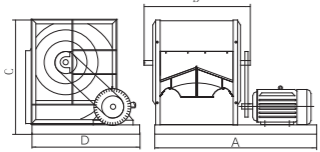
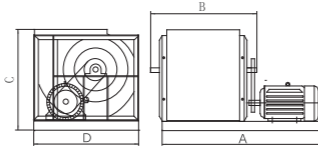
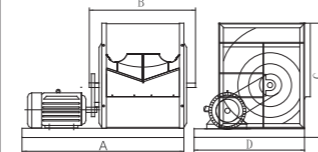
		0°			90°			180°		
左旋 LG Left Hand										
右旋 RD Right Hand										
型号 Model	电机 机座型号 Motor Frame Size	A	B	C	A	B	C	A	B	C
280	71	840	612	568	840	612	516	840	612	568
	80	840	612	568	840	612	516	840	612	568
	90	840	612	568	840	612	516	840	612	568
	100	840	612	568	840	612	516	840	612	568
	112	840	612	568	840	612	516	840	612	568
	132	840	612	568	840	612	516	840	612	568
315	71	880	617	628	880	617	568	880	617	628
	80	880	617	628	880	617	568	880	617	628
	90	880	617	628	880	617	568	880	617	628
	100	880	617	628	880	617	568	880	617	628
	112	880	617	628	880	617	568	880	617	628
	132	880	617	628	880	617	568	880	617	628
355	71	940	655	705	940	655	628	940	655	705
	80	940	655	705	940	655	628	940	655	705
	90	940	655	705	940	655	628	940	655	705
	100	940	655	705	940	655	628	940	655	705
	112	940	655	705	940	655	628	940	655	705
	132	940	655	705	940	655	628	940	655	705
400	80	1130	736	786	1130	736	613	1130	736	786
	90	1130	736	786	1130	736	613	1130	736	786
	100	1130	736	786	1130	736	613	1130	736	786
	112	1130	736	786	1130	736	613	1130	736	786
	132	1130	736	786	1130	736	613	1130	736	786
	160	1130	736	786	1130	736	613	1130	736	786
450	90	1210	827	877	1210	827	776	1210	827	877
	100	1210	827	877	1210	827	776	1210	827	877
	112	1210	827	877	1210	827	776	1210	827	877
	132	1210	827	877	1210	827	776	1210	827	877
	160	1210	827	877	1210	827	776	1210	827	877
	180	1210	827	877	1210	827	776	1210	827	877
	200	1210	827	877	1210	827	776	1210	827	877
500	90	1290	918	981	1290	918	863	1290	918	981
	100	1290	918	981	1290	918	863	1290	918	981
	112	1290	918	981	1290	918	863	1290	918	981
	132	1290	918	981	1290	918	863	1290	918	981
	160	1290	918	981	1290	918	863	1290	918	981
	180	1290	918	981	1290	918	863	1290	918	981
	200	1290	918	981	1290	918	863	1290	918	981

## SYH-R(K)

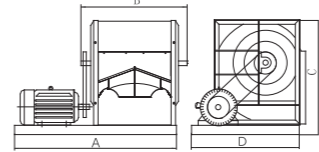
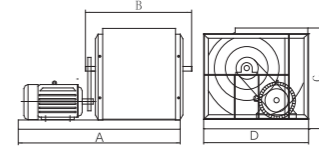
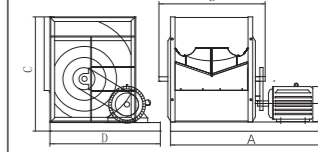
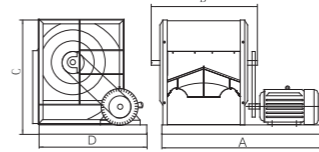
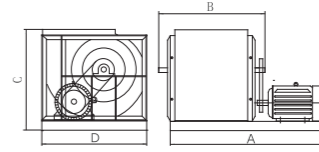
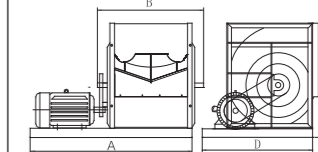
		0°			90°			180°		
左旋 LG Left Hand										
右旋 RD Right Hand										
型号 Model	电机 机座型号 Motor Frame Size	A	B	C	A	B	C	A	B	C
560	90	1410	1030	1093	1410	1030	956	1410	1030	1093
	100	1410	1030	1093	1410	1030	956	1410	1030	1093
	112	1410	1030	1093	1410	1030	956	1410	1030	1093
	132	1410	1030	1093	1410	1030	956	1410	1030	1093
	160	1410	1030	1093	1410	1030	956	1410	1030	1093
	180	1410	1030	1093	1410	1030	956	1410	1030	1093
	200	1410	1030	1093	1410	1030	956	1410	1030	1093
630	90	1510	1157	1220	1510	1157	1062	1510	1157	1220
	100	1510	1157	1220	1510	1157	1062	1510	1157	1220
	112	1510	1157	1220	1510	1157	1062	1510	1157	1220
	132	1510	1157	1220	1510	1157	1062	1510	1157	1220
	160	1510	1157	1220	1510	1157	1062	1510	1157	1220
	180	1510	1157	1220	1510	1157	1062	1510	1157	1220
	200	1510	1157	1220	1510	1157	1062	1510	1157	1220
710	100	1730	1303	1366	1730	1303	1491	1730	1303	1366
	112	1730	1303	1366	1730	1303	1491	1730	1303	1366
	132	1730	1303	1366	1730	1303	1491	1730	1303	1366
	160	1730	1303	1366	1730	1303	1491	1730	1303	1366
	180	1730	1303	1366	1730	1303	1491	1730	1303	1366
	200	1730	1303	1366	1730	1303	1491	1730	1303	1366
	225	1730	1303	1366	1730	1303	1491	1730	1303	1366
800	100	1870	1468	1548	1870	1468	1330	1870	1468	1548
	112	1870	1468	1548	1870	1468	1330	1870	1468	1548
	132	1870	1468	1548	1870	1468	1330	1870	1468	1548
	160	1870	1468	1548	1870	1468	1330	1870	1468	1548
	180	1870	1468	1548	1870	1468	1330	1870	1468	1548
	200	1870	1468	1548	1870	1468	1330	1870	1468	1548
	225	1870	1468	1548	1870	1468	1330	1870	1468	1548
900	132	2170	1648	1748	2170	1648	1748	2170	1648	1748
	160	2170	1648	1748	2170	1648	1748	2170	1648	1748
	180	2170	1648	1748	2170	1648	1748	2170	1648	1748
	200	2170	1648	1748	2170	1648	1748	2170	1648	1748
	225	2170	1648	1748	2170	1648	1748	2170	1648	1748
	250	2170	1648	1748	2170	1648	1748	2170	1648	1748
	280	2170	1648	1748	2170	1648	1748	2170	1648	1748
1000	132	2300	1810	1910	2300	1810	1641	2300	1810	1910
	160	2300	1810	1910	2300	1810	1641	2300	1810	1910
	180	2300	1810	1910	2300	1810	1641	2300	1810	1910
	200	2300	1810	1910	2300	1810	1641	2300	1810	1910
	225	2300	1810	1910	2300	1810	1641	2300	1810	1910
	250	2300	1810	1910	2300	1810	1641	2300	1810	1910
	280	2300	1810	1910	2300	1810	1641	2300	1810	1910

SYH系列风机运行极限

SYH Series Fan Operational Limits

			280	315	355	400	450	500	560	630	710	800	900	1000	1120	1250	1400	1600
极限吸收功率 Max.Absorbed power	R	KW	5.5	4.8	5.5	6	8	12	14	20	20	/	/	/	/	/	/	/
	K	KW	8	8	15	15	15	22	30	35	40	30	43	55	/	/	/	/
	Z	KW	/	/	/	/	/	30	38.5	40	60	65	65	80	180	220	280	350
	R2	KW	5.5	6.5	8.5	8.5	12	13	/	/	/	/	/	/	/	/	/	/
	K2	KW	/	/	13	13	18.5	22	32	/	/	/	/	/	/	/	/	/
极限转速 Max.Speed	R	rpm	4000	3200	2800	2400	2200	2000	1800	1700	1400	/	/	/	/	/	/	/
	K	rpm	4500	4000	3800	3200	2800	2500	2300	2000	1700	1300	1200	1100	/	/	/	/
	Z	rpm	/	/	/	/	/	2800	2500	2200	2000	1600	1400	1300	1450	1300	1150	1000
	R2	rpm	3200	2800	2600	2100	1800	1600	/	/	/	/	/	/	/	/	/	/
极限温度 (最低-20°C) Air Temperature Limits(Min-20°C)	R/R2	Max.°C	85	85	85	85	85	85	85	85	85	/	/	/	/	/	/	/
	K/K2	Max.°C	85	85	85	85	85	85	85	85	85	85	85	85	/	/	/	/
	Z	Max.°C	/	/	/	/	/	85	85	85	85	85	85	85	85	85	85	85
风机质量 Fan Weight	R	Kg	22	32.6	42.7	50.6	67.5	84.2	142	168	223	/	/	/	/	/	/	/
	K	Kg	32	42.6	54.7	63.6	82.5	104.2	171	197	271	300	481.5	530	/	/	/	/
	Z	Kg	/	/	/	/	/	107	174	200	274	304	485	535	690	970	1370	1500
	R2	Kg	46	67	91	107	143	176	/	/	/	/	/	/	/	/	/	/
	K2	Kg	/	/	111	127	173	217	358	/	/	/	/	/	/	/	/	/

本样本中所述的风机特性，如尺寸、性能参数等，本公司保留更改的权利，恕不另行通知；如有不明之处，请来电询问。  
This fan features described in the sample, such as size, performance parameters, the Company reserves the right to change without notice; if unknown place, please call us.

SYQS 系列离心式空调风机

Centrifugal Ventilators

浙江亿利达风机股份有限公司特此证明，此处所示 SYQS 系列离心风机获得了加盖 AMCA 印章的授权。所示额定值系根据 AMCA 出版物 211 和 AMCA 出版物 311 所进行测试和程序确定，并符合 AMCA 认证额定值计划的要求。

这里描述的所有离心风机都已经取得了 AMCA 印章，他们的认证数据见第 171 页到 185 页。

Zhejiang Yilida Ventilator Co.,Ltd. certifies that the SYQS Series fans shown herein are licensed to bear the AMCA Seal. The ratings shown are based on tests and procedures performed in accordance with AMCA Publication 211 and AMCA Publication 311 and comply with the requirements of the AMCA Certified Ratings Program.

All the Centrifugal Fans described herein are licensed to bear the AMCA Seal, and their certified ratings are shown on pages 171 through 185.





概述

SYQS 系列后向单进风离心风机采用国际同类产品先进技术自行开发,通过了 AMCA 国际认证并取得 AMCA 印章。该样本列出的 15 种规格风机,流量范围从 700m³/h-120000m³/h,全压从 200Pa-3000Pa,产品具有效率高、噪声低、耗能少、通用性强、安全性好等特点。广泛应用与各类中央空调机组及其他暖通空调、净化、通风等空调系统。

Summary

The SYQS Series of centrifugal fans with backward blade were developed with advanced technologies. They are licensed to bear the AMCA Seal for air performance, sound, and FEG. The SYQS Series includes 15 models as described in this catalogue. The volume flow of the SYQS Series ranges from 1,000 m³/h to 120,000 m³/h, the total pressure ranges from 200Pa to 3,000 Pa. Some of the features and characteristics of these fans are: forward impeller blades, a wide range of applications, high efficiency, low noise, and low power consumption. These fans are ideal for use in central air-conditioning systems, in purifiers. They are also suitable for use in a variety of other ventilation.

命名方式

SYQS— 560 R

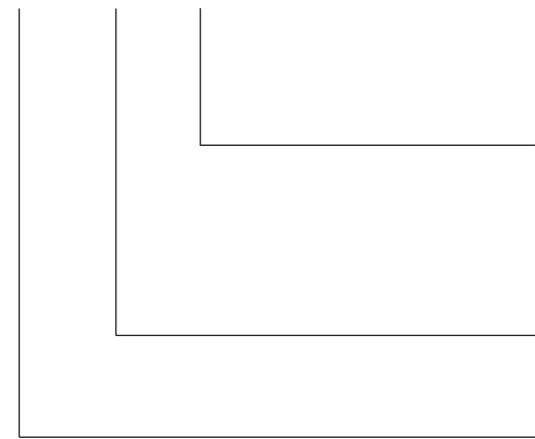

Nomenclature

- 结构型式 Construction type
- R 型(基本型) Type R (Basic Model)
- E 型(加强型) Type E (Heavy Duty Model)
- C 型(悬臂型) Type C (Handing Model)
- 叶轮名义直径(mm) Nominal diameter of impeller (mm)
- 后向单进风离心风机系列代号 Series fan of single inlet with backward blades

产品类型

1. 旋向

SYQS 系列风机可分为左旋(LG)和右旋(RD)两种旋转方式,从风机皮带轮一端正视,叶轮顺时针旋转的称为右旋风机,逆时针旋转的称为左旋风机。

1. Rotation

SYQS series fans have two direction of rotations, left-hand rotation (LG) and right-hand rotation (RD); Viewing from drive side, if the impeller rotates clockwise, it is left hand (LG) rotation. If the impeller rotates counter clockwise, it is right-hand (RD).

2. 出风口方向

SYQS 系列出风口可按图 1 所示制成 0°、90°、180°、270° 四种出风方向。

2. Discharge Direction

As shown in Fig1, SYQS Series fans can be constructed in four discharge directions: 0°, 90°, 180°, and 270°.

图 1 (Fig 1)

	0°	90°	180°	270°
左旋 LG Left Hand				
右旋 RD Right Hand				

3. 结构形式

SYQS 系列风机可按图 2 所示制成 R 型、E 型、C 型。

3. Type of Construction

As shown in Fig 2, SYQS series fans can be divided into category R, E, C.

图 2 (Fig 2)

风机类型 Fan Type	机号 Fan Size	风机示意图 Fan Diagram	轴承实物图 Bearing Type
R 型 TYPE R	280-710		
E 型 TYPE E	280-1000		
C 型 TYPE C	280-1400		

## 产品结构

SYQS 系列风机主要由机壳、叶轮、框架、轴承及轴构成。出口法兰(为可选件)。

### 1. 机壳

机壳采用热镀锌钢板制造,侧板具有符合空气动力的外形,进风口整体拉伸成型,蜗板采用点焊或“Pittsburg seam locking”的连接方式与侧板连成一体。

### 2. 叶轮

后向叶轮采用优质冷轧钢板制成,按三元流理论设计的机翼型叶片焊接在高精度激光切割机床加工的中盘和端圈上,整体喷塑。所有叶轮进行静平衡和动平衡测试,内控精度达到 G2.5 级(ANSI/AMCA 204-05)。

### 3. 框架

R 型风机框架采用热镀锌钢板剪切、折弯制成,TOX 连接保证了所需的尺寸精度和应有的刚度;E 型、C 型风机框架由角钢和扁钢冷弯焊接制成表面喷塑处理,以保证足够的刚度和强度。

### 4. 轴承

SYQS 系列风机均采用优质滚珠轴承,并根据噪声最低来选择,该轴承设有加润滑油的孔,已预先加润滑油并自动对中;R 型风机的轴承安装在轴承支架上,并设有防振垫圈;E 型、C 型风机则采用带座向心球轴承;轴承寿命为  $L_{10} \geq 100000$  小时。

### 5. 轴

风机轴采用 40Cr 低合金钢,经车、调质热处理、磨削制成,强度高,挠度小,严格控制轴径尺寸公差及形位公差,每根轴均经过涂覆防锈处理。轴尺寸设计应满足第一临界转速至少为风机最大运行速度的 1.4 倍。

### 6. 出风口法兰

进风口法兰采用优质冷轧板制成,整体喷塑。出风口法兰采用热镀锌钢板制成,出风口法兰与蜗板的连接采用 TOX 免焊工艺,外观精美,并具有足够的刚度与强度。

## Construction of Product

SYH series fans are mainly constructed of housing, impeller, frame, bearing and shaft. Outlet flange (is optional).

### 1. Housing

The housing is made of hot galvanized steel sheet. The side plates include inlets cones that are designed with the best aerodynamics for inlet condition. The scroll is fixed to the side plates by spot welding or "Pittsburg seam locking."

### 2. Impeller

Backwards curved airfoil impeller is constructed of high-grade cold-roll steel sheets, according to the three-dimensional flow theory, the impeller is fixed on the center plate and on the end ring with welding by high precision laser cutting machine. the unity of the impeller is spraying by plastic. All impellers are balanced to ANSI/AMCA Standard 204-05. Yilida's internal standard is G2.5 or higher for wheel balancing.

### 3. Frame

The frames for type R construction are made of galvanized steel angle iron bars. The cutting and bending of the frame parts, as well as the TOX connections, are formed with the use of toolings to ensure the high accuracy and the rigidity of the frames; The frames for E and C constructions are welded by angle steel and flat steel with polyester coating in order to ensure sufficient rigidity and strength.

### 4. Bearings

Ball bearings are used in all of the SYQS Series fans. These are high-quality bearings and selected to minimize the fan noise levels. The bearings are pre-lubricated, sealed, and self-centering. For type R constructions, the bearings are supplied with lubrication fittings. For type E and C constructions, the bearings are supplied with radial bearing. Yilida bearing service life ( $L_{10}$ ) are over 100,000 hours ( $L_{10} \geq 100000$  hours).

### 5. Shaft

The shafts are made of 40 Cr carbon steel bars. The shafts are rough machined and then stress relieved with heat treatment before final machining. The shaft diameters are machined to very accurate tolerance levels, and they are fully checked to ensure precision fit. Each shaft is made turned, ground and polished. They are coated after assembly to provide corrosion resistance. Shaft size should be designed to meet the first critical speed of at least fan maximum running speed 1.4 times.

### 6. Outlet Flange

The inlet flange is made of high-grade cold-rolling sheet with polyester coating. The outlet flange is made of galvanized steel. The connections of the flange components to the scroll are made using a TOX non-welding process. This maintains a good flange appearance while also providing sufficient strength and rigidity.

## 风机性能

### 1、风机选型示意图例

型号 Type	SYQS710K
风量 Volume	$q_v=16000\text{m}^3/\text{h}$
全压 Total Pressure	$P_{IF}=1600\text{Pa}$
动压 Dynamic Pressure	$P_{dF}=64\text{Pa}$
出口速度 Outlet Velocity	$C=10.35\text{m/s}$
风机转速 Fan Speed	$n=1430\text{r/min}$
轴功率 Shaft Power	$P_{sh}=9.5\text{KW}$
A声功率级 A Sound Power Level	$L_{WA}=94\text{dB(A)}$
全压效率 Total Efficiency	$\eta_{IF}=74\%$

## Performance Chart

### 1. Fan Performance Curve

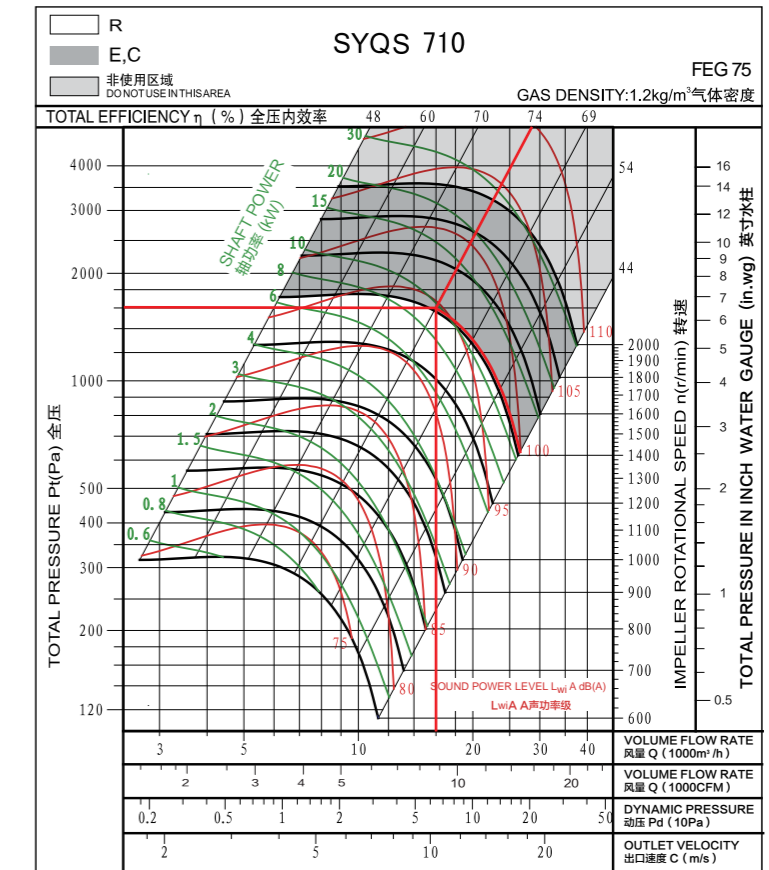

## 2、电机的选配

性能曲线图上的功率 Psh 是指风机的轴功率。

配套电机的功率:  $P_{sh,p} = P_{sh} \times K \div \eta_{me}$

风机传动效率的取值方法可参照表 1,

电机容量安全系数的取值方法可参照表 2。

表 1 (Table 1)

风机传动方式	Drive Type	$\eta_{me}$
电机直联传动	Motor Direct Drive	1
联轴器直联传动	Coupling Direct Drive	0.98
三角皮带传动	V-Belt Drive	0.95

## 2. Motor Selection

The power (Psh) on the performance chart refers to the shaft power of the fan.

The rated power of the drive motor equals the total required shaft input multiplied by the safety factor:  $P_{sh,p} = P_{sh} \times K \div \eta_{me}$   
The value of mechanical drive efficiency can be obtained from Table 1.

The required safety factors is provided in Table 2.

表 2 (Table 2)

电机功率	Power of electric motor (Kw)	K值 Value k
$\leq 0.75Kw$		1.3
$\leq 2.2Kw$		1.2
$\leq 7.5Kw$		1.15
$\geq 11Kw$		1.1

## 安装与维护

## Installation and Maintenance

### A) 皮带传动安装

1. 拆除风机轴端的保护并检查有无缺口和毛刺;
2. 检查风机和电机轴之间的平行度;
3. 中心距控制在  $0.7(d1+d2) < a < 2(d1+d2)$ , 前向风机皮带速度应控制在 10~15m/s; 后向风机皮带速度应控制在 25~35m/s;
4. 将皮带轮套在轴上滑进去, 不要敲击, 以免损伤轴承;
5. 用一根直尺把风机和电机上的带轮对齐并紧固;
6. 把皮带套进皮带轮, 不要撬、挤压, 以免损伤皮带;
7. 调整张紧度直至皮带看起来松紧适度, 风机运行几分钟后, 再调整皮带至合适的张紧度;
8. 关掉风机, 移动电机座以调整张紧度, 当风机工作时, 皮带紧的一边是两个皮带轮连成的一条直线, 松的一边有轻微弧形。

### A) V-belt Drive Installation

1. Remove the protective coating from the ends of the fan shaft and ensure that the shaft ends are free of nick and burrs.
2. Check fan and motor shafts for alignment.
3. The center distance must be controlled as  $0.7(d1+d2) < a < 2(d1+d2)$ , The belt speed of forward curve fan should be more than 10m/s, but less than 15m/s, ( $10 < v < 15m/s$ ). The belt speed of backward curve fan should be more 25m/s, but less than 35m/s ( $25 < v < 35m/s$ ).
4. Slide sheaves on to the shafts, Do not hammer the sheaves on to the shafts with force as this may result in bearing damage.
5. Align fan and motor sheaves with a straight-edge, and tighten the sheaves.
6. Place belts over the sheaves with care. Do not bend or squeeze the belts or it might get damaged.
7. Adjust the belt tension until the belts appear snug. Run the unit for a few minutes and allow the belts to set properly.
8. Switch off the fan, adjust the belt tension by moving the motor base. When in operation, the tight side of the belts should be in a straight line from sheave to sheave and there should be a slight bow on the slack side.

图 3 (Fig3)

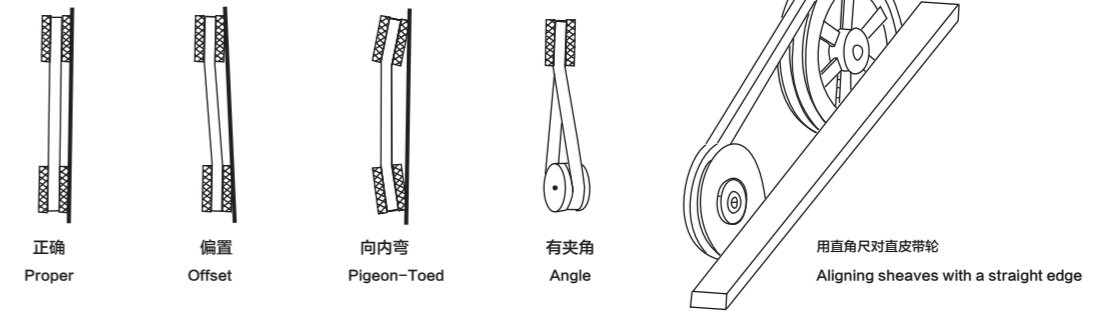

### B) 皮带松紧度

合适的皮带松紧度对使用寿命来说很重要, 太紧会给皮带和轴承带来额外的负载, 降低它们的使用寿命, 太松会出现皮带打滑现象而产生热能并降低使用寿命。

皮带松紧度量具用来判断皮带是否松紧合适。量具本身带有一个尺表, 根据皮带轮中心距和皮带横截面确定皮带张紧力的大小, 如图 4 和表 3。

如没有皮带张紧度量具, 应调节皮带松紧至风机启动时皮带不发生尖叫声为止, 如发生短促的叫声是允许的。

拉紧皮带后、开动风机之前, 重新检查皮带轮的对齐情况, 如右必要则重新调整对齐。新皮带在开始使用时可能有点拉伸, 则应在运行几天后重新检查皮带张紧度。

### B) Belt Tension

A proper level of belt tension is required in order to obtain a satisfactory belt life. If the belt tension level is too high, excessive loads will be imposed on the belts and the bearing, and this will reduce the lives of both of these components. If the belt tension level is too low, the belt will slip. Belt slippage generates a large amount of heat, and this heat will drastically reduce the life of a belt.

Belt-tensioning gauges can be used to determine whether the belts are tensioned properly. A chart is normally supplied with the gauge which indicates the ranges of forces required to deflect the belts by a given amount to obtain the proper belt tension level. The required forces are based upon the center distance of the sheaves and the belt cross-section. The belts are properly tensioned when the forces required to deflect the belt are within the specified range, see Fig 4 and Table 3.

If a belt-tensioning gauge is not available, then the belt should be tightened just enough so that the belt does not squeal when the ventilator is started. A very short period of noise during the starting of a ventilator is allowable, but a squeal lasting several seconds or longer is not acceptable. After tensioning the belts and before starting the fan, check to make sure that the sheaves are properly aligned.

Realign the sheaves if necessary. Note that new belts may stretch a little during initial use, so the belt tension level should be checked after a few days of operation.

表 4 (Fig4)

与中心距有关的皮带张紧度指示  
Belt tension indicator applied to mid centre distance.



表 3 (Table3)

皮带截面 Belt Section	使皮带向下移动16mm径向距离1米所需的力 Force required to deflect belt 16mm per metre of span		
	张紧力 (小皮带轮直径) Small Pulley Diameter (mm)	牛顿 Newtonian (N)	千克力 Kilogram force (Kgf)
SPZ	56-95	13-20	1.3-2.0
	100-140	20-25	2.0-2.5
SPA	80-132	25-35	2.5-3.6
	140-200	35-45	3.6-4.6
SPB	112-224	45-65	4.6-6.6
	236-315	65-85	6.6-8.7
SPC	224-335	85-115	8.7-11.7
	375-560	115-150	11.7-15.3
A	80-140	10-15	1.1-1.5
B	125-200	20-30	2.0-3.1

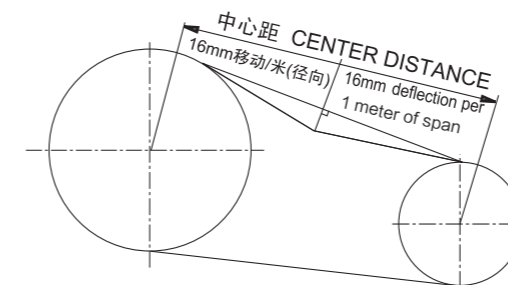

### C) 轴承润滑

风机使用带座轴承，可通过加油嘴注入润滑油。润滑油有效期取决于油脂类型、轴承的转速和工作温度。判断是否加油的最好办法是当加新油时观察清除下来的旧油脂，可延长换油脂的间隔，如果清除下来的油脂比新的黑得多表明油脂已氧化，应缩短换油脂的间隔。

### C) Bearing Lubrication

The allowable period of time between lubrication of these bearings depends upon the operating speeds and temperatures of the bearing as well as on the type of lubrication. It is recommended to inspect the condition of the grease that is discharged from the bearings when new grease is added. If the discharged grease looks similar to the new grease, then a longer period of time between lubrications is possible. If the discharged grease is much darker than the new grease, this indicates that the grease is being oxidized and more frequent lubrications of the bearings are required.

### 说明

- 1). 订货时须注明风机型号、转速、风量、风压、出风口方向和旋转方向。若需配套皮带、皮带轮、电机、安装底座等配件及其它特殊要求可在订货时提出。
- 2). 在安装前应对风机各部件进行检查，对叶轮、主轴和轴承等主要机件应重点细致检查，如有损伤应修复后再安装使用。
- 3). 检查机壳和其它壳体内部，不应有掉入、遗留的工具和杂物。
- 4). 风机正式运转前，需检查电机的转向是否符合风机转向的要求。
- 5). 风管与出风口之间应采用软连接，接头不得拉紧。
- 6). 风机安装后用手或杠杆拨动叶轮，检查是否过紧或碰撞现象，确认无这些现象时方向可进行试转。
- 7). 风机配用电动机功率是指在特定工况下，风机内功率加上机械损失与电机容量安全系数而言，并非出风口全敞开时所需的功率。为防止电机超功率运行而烧毁，严禁风机出风口或进风口不接管路或未加外界任何阻力进行空运转。
- 8). 风机在无较大腐蚀性气体、不含酸（碱）性和尘颗粒物小于 150mg/m<sup>3</sup> 的气体、温度小于 85℃ 大于 -20℃ 的气体环境下使用，风机在运输装卸过程中应小心轻放，防止碰撞挤压。

### Instructions

- 1) When placing the order, it is necessary to state the type of fan, speed, air volume, air pressure, discharge direction, rotation direction, type of electric motor and its specifications.
- 2) Prior to installation, the fan should be carefully inspected. Special care should be taken in checking the shaft, impeller and bearings. If there is an indication of any damage, the damaged parts should be repaired or replaced before the fan is installed or commissioned.
- 3) The inside of the scroll and casing need to be checked to make sure that there are no foreign objects inside the housing, such as tools or loose parts.
- 4) The rotational directions of the motor and impeller should be checked to ensure that they are in compliance with the specification and purchase orders.
- 5) A flexible connector should be used between the fan out let flange and its mating ductwork. The flex connector should not be over-stretched.
- 6) Following the installation, the impeller should be turned by hand or with the use of a wrench to make sure that it turns freely without colliding with other parts of the fan. Once all this is done, the fan can be commissioned normally.
- 7) The rated motor power as calculated herein might not be sufficient to drive the fan with an unrestricted discharge flow. Operating the fan with an unrestricted discharge outlet will result in flow rate that exceeds the specified fan capabilities. Such operation will quickly burn the motor and damage the fan. Great care must be taken in operating the fan to make sure that the maximum rated flows, as provided on the performance charts in this catalog, are not exceeded.
- 8) The fan is limited for use in areas where air substances are non-corrosive, non-toxics and non-erosive and where dust particles are less than 150mg/m<sup>3</sup> with a temperature between -20 C and 85 C. Special care should be taken during transportation, load and unload.

### 技术参数

Wheel diameter	叶轮直径	D = 280 mm	Fan weight	风机质量	m = 17 kg
Moment of inertia	转动惯量	J = 0.04kg·m <sup>2</sup>	Speed limit	极限转速	n <sub>max</sub> = 4500 r/min

### Technical Data

### 性能曲线

经认证的性能是B类安装：自由入口，管道出口。功率额定值(kW)不包括传输损失。各项性能额定值不包括附属物(附件)的影响。所示A加权声音性能额定值已按AMCA International标准301计算。所示值为安装类型B：自由入口，管道出口的声功率级（入口L<sub>wA</sub>）。

### Performance Curve

Performance certified is for installation type B: free inlet, ducted outlet. Power rating (kW) does not include transmission losses. Performance ratings do not include the effects of appurtenances (accessories). The A-weighted sound ratings shown have been calculated per AMCA International Standard 301. Values shown are for inlet L<sub>wA</sub> sound power levels for installation type B: free inlet, ducted outlet.

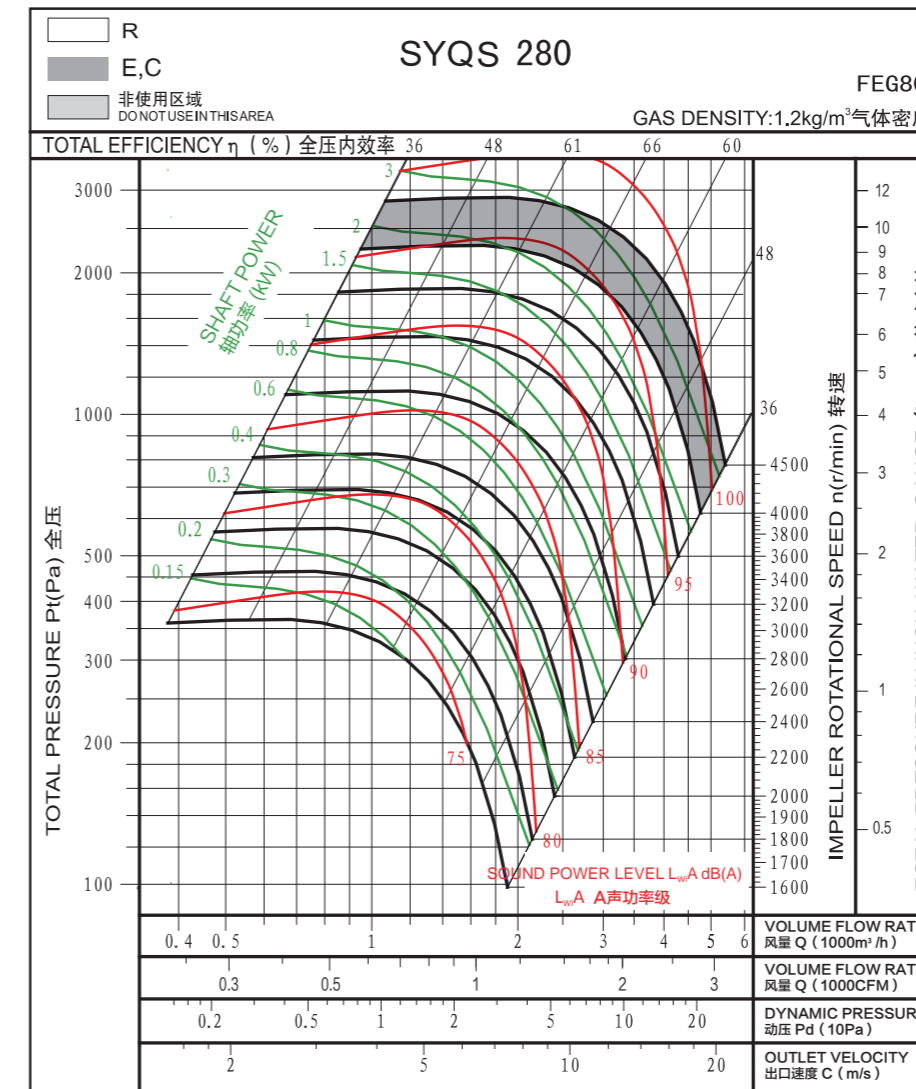

Measured in installation B according to AMCA Standard 210:

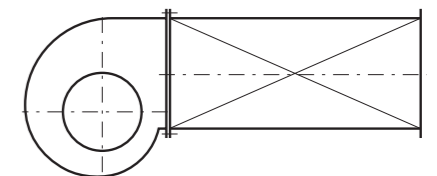

### 技术参数

### Technical Data

Wheel diameter 叶轮直径	D = 315 mm	Fan weight 风机质量	m = 27 kg
Moment of inertia 转动惯量	J = 0.06kg·m <sup>2</sup>	Speed limit 极限转速	n <sub>max</sub> = 4000 r/min

### 技术参数

### Technical Data

Wheel diameter 叶轮直径	D = 355 mm	Fan weight 风机质量	m = 39kg
Moment of inertia 转动惯量	J = 0.112kg·m <sup>2</sup>	Speed limit 极限转速	n <sub>max</sub> = 3800 r/min

### 性能曲线

### Performance Curve

经认证的性能是B类安装：自由入口，管道出口。功率额定值(kW)不包括传输损失。各项性能额定值不包括附属物(附件)的影响。所示A加权声音性能额定值已按AMCA International标准301计算。所示值为安装类型B：自由入口，管道出口的声功率级（入口L<sub>WA</sub>）。

Performance certified is for installation type B: free inlet, ducted outlet. Power rating (kW) does not include transmission losses. Performance ratings do not include the effects of appurtenances (accessories). The A-weighted sound ratings shown have been calculated per AMCA International Standard 301. Values shown are for inlet L<sub>WA</sub> sound power levels for installation type B: free inlet, ducted outlet.

### 性能曲线

### Performance Curve

经认证的性能是B类安装：自由入口，管道出口。功率额定值(kW)不包括传输损失。各项性能额定值不包括附属物(附件)的影响。所示A加权声音性能额定值已按AMCA International标准301计算。所示值为安装类型B：自由入口，管道出口的声功率级（入口L<sub>WA</sub>）。

Performance certified is for installation type B: free inlet, ducted outlet. Power rating (kW) does not include transmission losses. Performance ratings do not include the effects of appurtenances (accessories). The A-weighted sound ratings shown have been calculated per AMCA International Standard 301. Values shown are for inlet L<sub>WA</sub> sound power levels for installation type B: free inlet, ducted outlet.

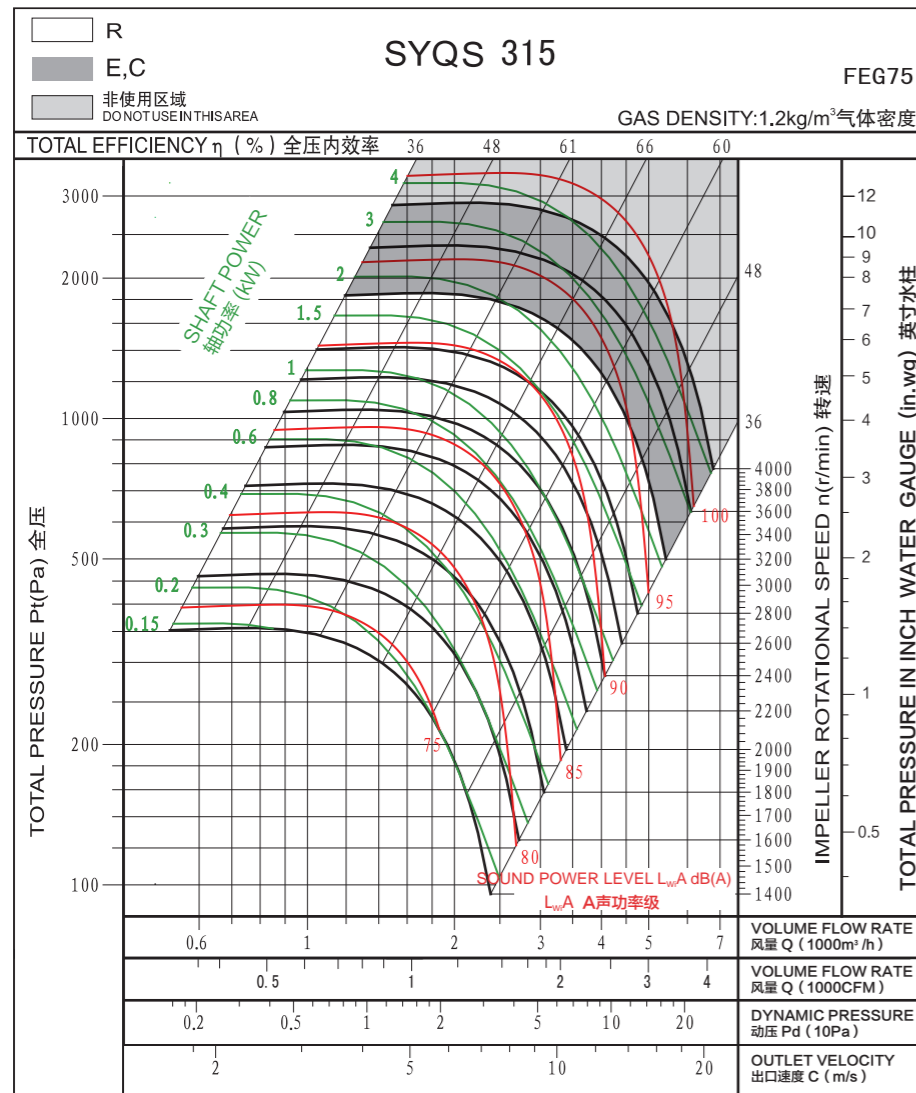

Measured in installation B according to AMCA Standard 210:

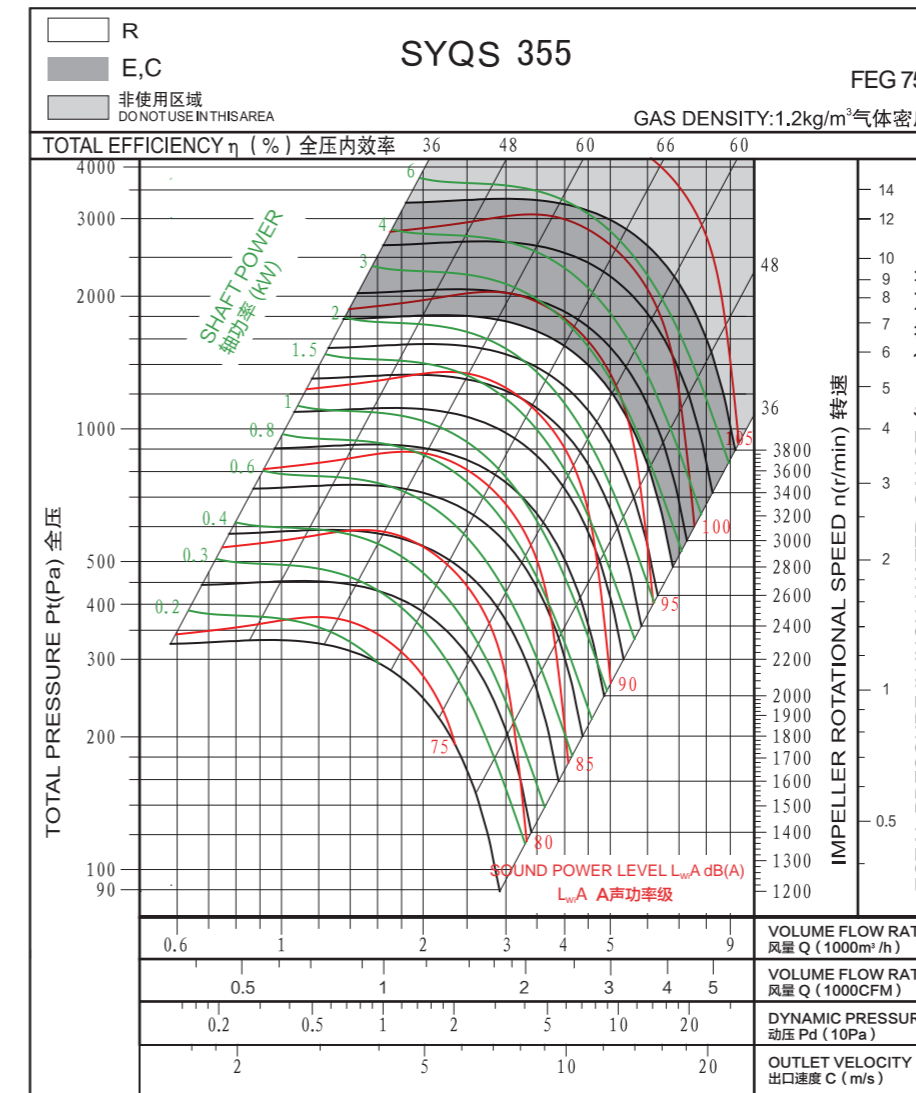
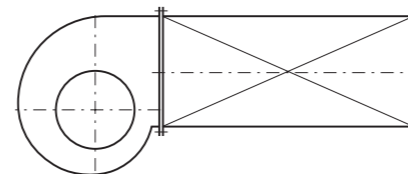

Measured in installation B according to AMCA Standard 210:

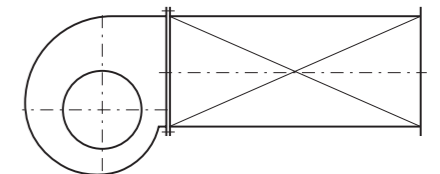

## 技术参数

## Technical Data

Wheel diameter 叶轮直径	D = 400 mm	Fan weight 风机质量	m = 44 kg
Moment of inertia 转动惯量	J = 0.185kg·m <sup>2</sup>	Speed limit 极限转速	n <sub>max</sub> = 3200 r/min

## 技术参数

## Technical Data

Wheel diameter 叶轮直径	D = 450 mm	Fan weight 风机质量	m = 55 kg
Moment of inertia 转动惯量	J = 0.06kg·m <sup>2</sup>	Speed limit 极限转速	n <sub>max</sub> = 2800 r/min

## 性能曲线

## Performance Curve

经认证的性能是B类安装：自由入口，管道出口。功率额定值(kW)不包括传输损失。各项性能额定值不包括附属物(附件)的影响。所示A加权声音性能额定值已按AMCA International标准301计算。所示值为安装类型B：自由入口，管道出口的声功率级（入口L<sub>wA</sub>）。

Performance certified is for installation type B: free inlet, ducted outlet. Power rating (kW) does not include transmission losses. Performance ratings do not include the effects of appurtenances (accessories). The A-weighted sound ratings shown have been calculated per AMCA International Standard 301. Values shown are for inlet L<sub>wA</sub> sound power levels for installation type B: free inlet, ducted outlet.

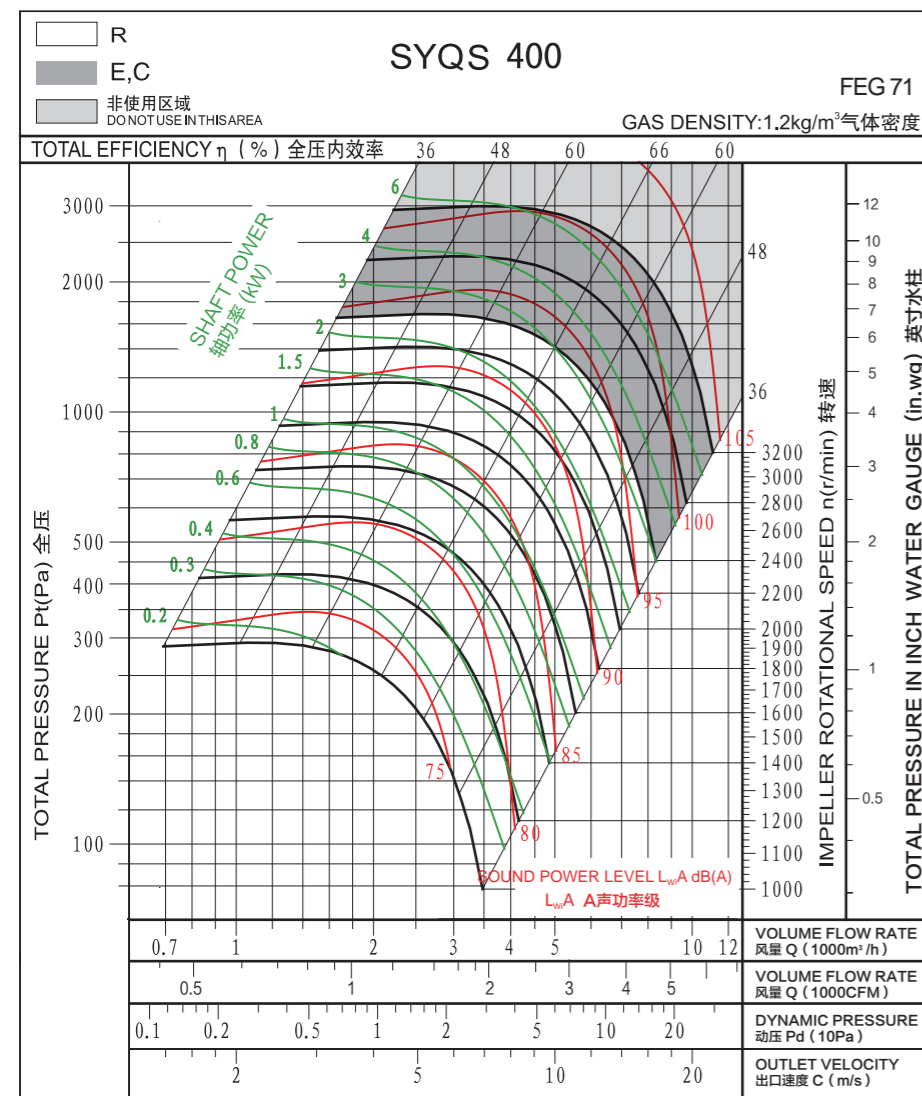

## 性能曲线

## Performance Curve

经认证的性能是B类安装：自由入口，管道出口。功率额定值(kW)不包括传输损失。各项性能额定值不包括附属物(附件)的影响。所示A加权声音性能额定值已按AMCA International标准301计算。所示值为安装类型B：自由入口，管道出口的声功率级（入口L<sub>wA</sub>）。

Performance certified is for installation type B: free inlet, ducted outlet. Power rating (kW) does not include transmission losses. Performance ratings do not include the effects of appurtenances (accessories). The A-weighted sound ratings shown have been calculated per AMCA International Standard 301. Values shown are for inlet L<sub>wA</sub> sound power levels for installation type B: free inlet, ducted outlet.

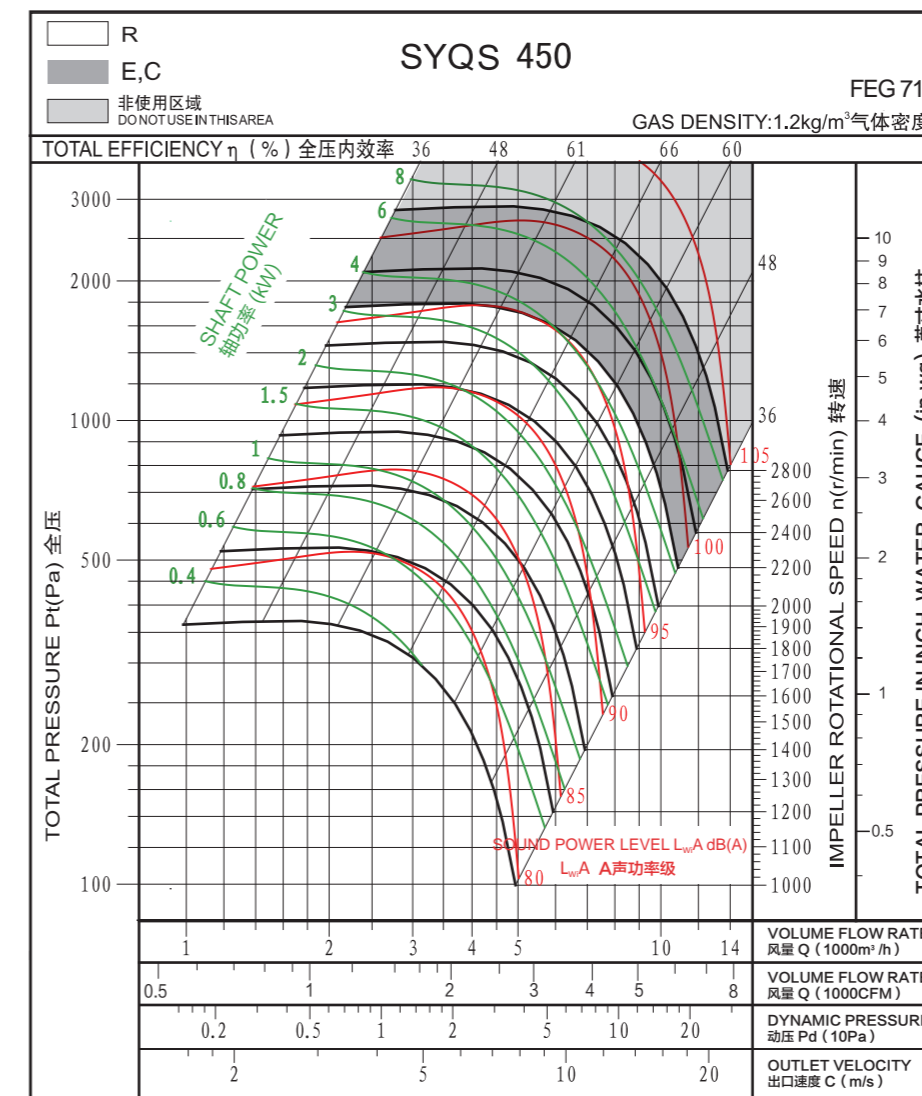



### 技术参数

### Technical Data

Wheel diameter 叶轮直径	D = 500 mm	Fan weight 风机质量	m = 70 kg
Moment of inertia 转动惯量	J = 0.49 kg·m <sup>2</sup>	Speed limit 极限转速	n <sub>max</sub> = 2800 r/min

### 技术参数

### Technical Data

Wheel diameter 叶轮直径	D = 560 mm	Fan weight 风机质量	m = 110 kg
Moment of inertia 转动惯量	J = 0.78 kg·m <sup>2</sup>	Speed limit 极限转速	n <sub>max</sub> = 2600 r/min

### 性能曲线

### Performance Curve

经认证的性能是B类安装：自由入口，管道出口。功率额定值(kW)不包括传输损失。各项性能额定值不包括附属物(附件)的影响。所示A加权声音性能额定值已按AMCA International标准301计算。所示值为安装类型B：自由入口，管道出口的声功率级（入口L<sub>WA</sub>）。

Performance certified is for installation type B: free inlet, ducted outlet. Power rating (kW) does not include transmission losses. Performance ratings do not include the effects of appurtenances (accessories). The A-weighted sound ratings shown have been calculated per AMCA International Standard 301. Values shown are for inlet L<sub>WA</sub> sound power levels for installation type B: free inlet, ducted outlet.

### 性能曲线

### Performance Curve

经认证的性能是B类安装：自由入口，管道出口。功率额定值(kW)不包括传输损失。各项性能额定值不包括附属物(附件)的影响。所示A加权声音性能额定值已按AMCA International标准301计算。所示值为安装类型B：自由入口，管道出口的声功率级（入口L<sub>WA</sub>）。

Performance certified is for installation type B: free inlet, ducted outlet. Power rating (kW) does not include transmission losses. Performance ratings do not include the effects of appurtenances (accessories). The A-weighted sound ratings shown have been calculated per AMCA International Standard 301. Values shown are for inlet L<sub>WA</sub> sound power levels for installation type B: free inlet, ducted outlet.

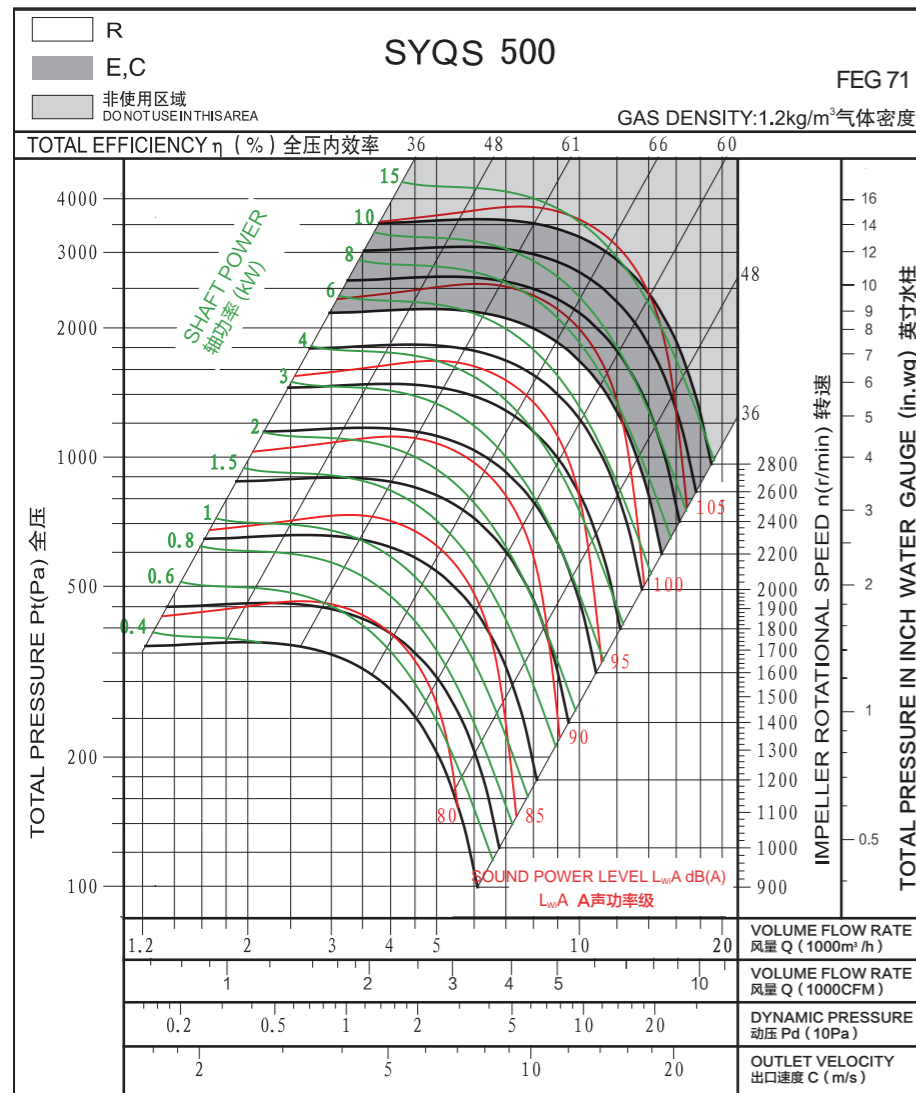

Measured in installation B according to AMCA Standard 210:

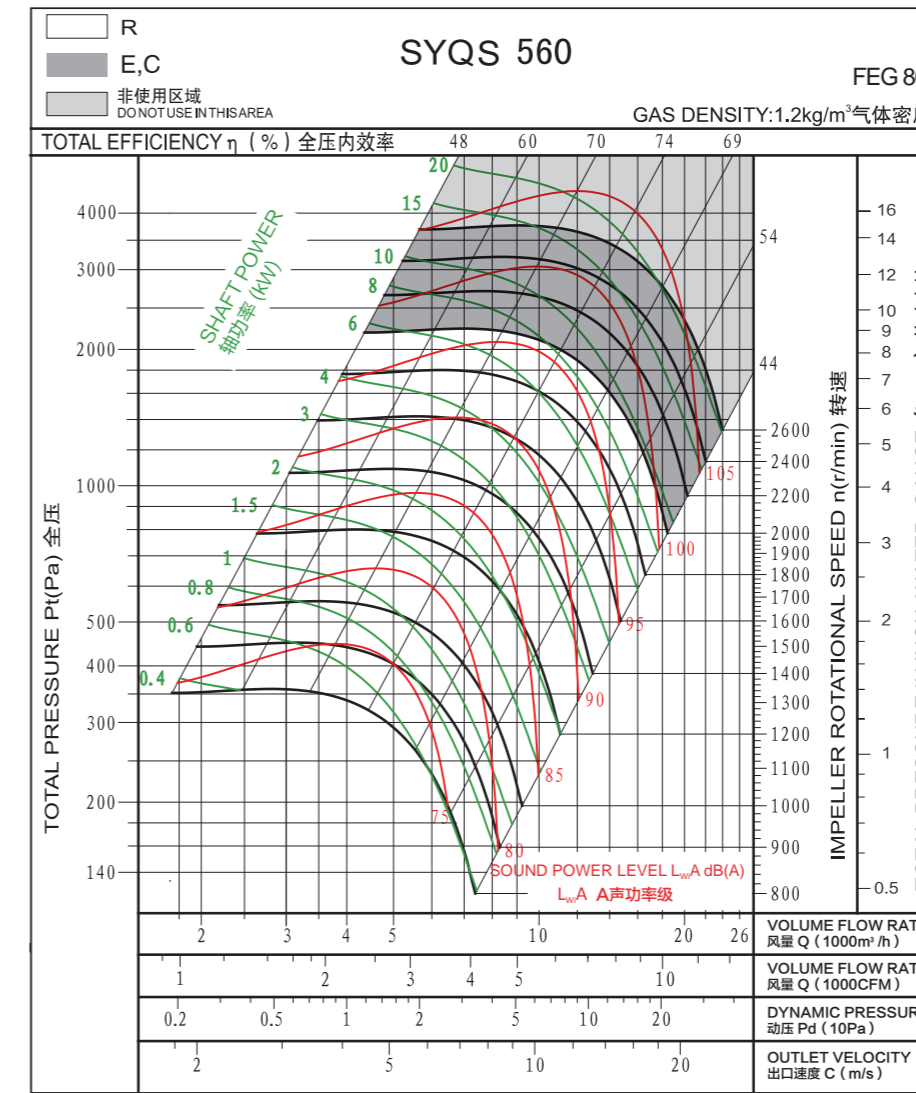
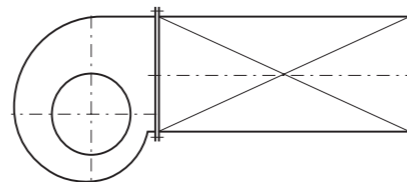

Measured in installation B according to AMCA Standard 210:

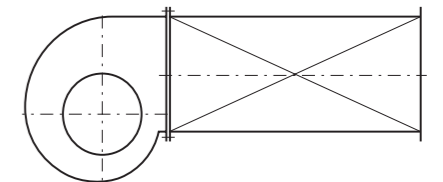

## 技术参数

## Technical Data

Wheel diameter 叶轮直径	D = 630 mm	Fan weight 风机质量	m = 125 kg
Moment of inertia 转动惯量	J = 1.28 kg·m <sup>2</sup>	Speed limit 极限转速	n <sub>max</sub> = 2200 r/min

## 技术参数

## Technical Data

Wheel diameter 叶轮直径	D = 560 mm	Fan weight 风机质量	m = 110 kg
Moment of inertia 转动惯量	J = 0.78 kg·m <sup>2</sup>	Speed limit 极限转速	n <sub>max</sub> = 2600 r/min

## 性能曲线

## Performance Curve

经认证的性能是B类安装：自由入口，管道出口。功率额定值(kW)不包括传输损失。各项性能额定值不包括附属物(附件)的影响。所示A加权声音性能额定值已按AMCA International标准301计算。所示值为安装类型B：自由入口，管道出口的声功率级（入口L<sub>WA</sub>）。

Performance certified is for installation type B: free inlet, ducted outlet. Power rating (kW) does not include transmission losses. Performance ratings do not include the effects of appurtenances (accessories). The A-weighted sound ratings shown have been calculated per AMCA International Standard 301. Values shown are for inlet L<sub>WA</sub> sound power levels for installation type B: free inlet, ducted outlet.

## 性能曲线

## Performance Curve

经认证的性能是B类安装：自由入口，管道出口。功率额定值(kW)不包括传输损失。各项性能额定值不包括附属物(附件)的影响。所示A加权声音性能额定值已按AMCA International标准301计算。所示值为安装类型B：自由入口，管道出口的声功率级（入口L<sub>WA</sub>）。

Performance certified is for installation type B: free inlet, ducted outlet. Power rating (kW) does not include transmission losses. Performance ratings do not include the effects of appurtenances (accessories). The A-weighted sound ratings shown have been calculated per AMCA International Standard 301. Values shown are for inlet L<sub>WA</sub> sound power levels for installation type B: free inlet, ducted outlet.

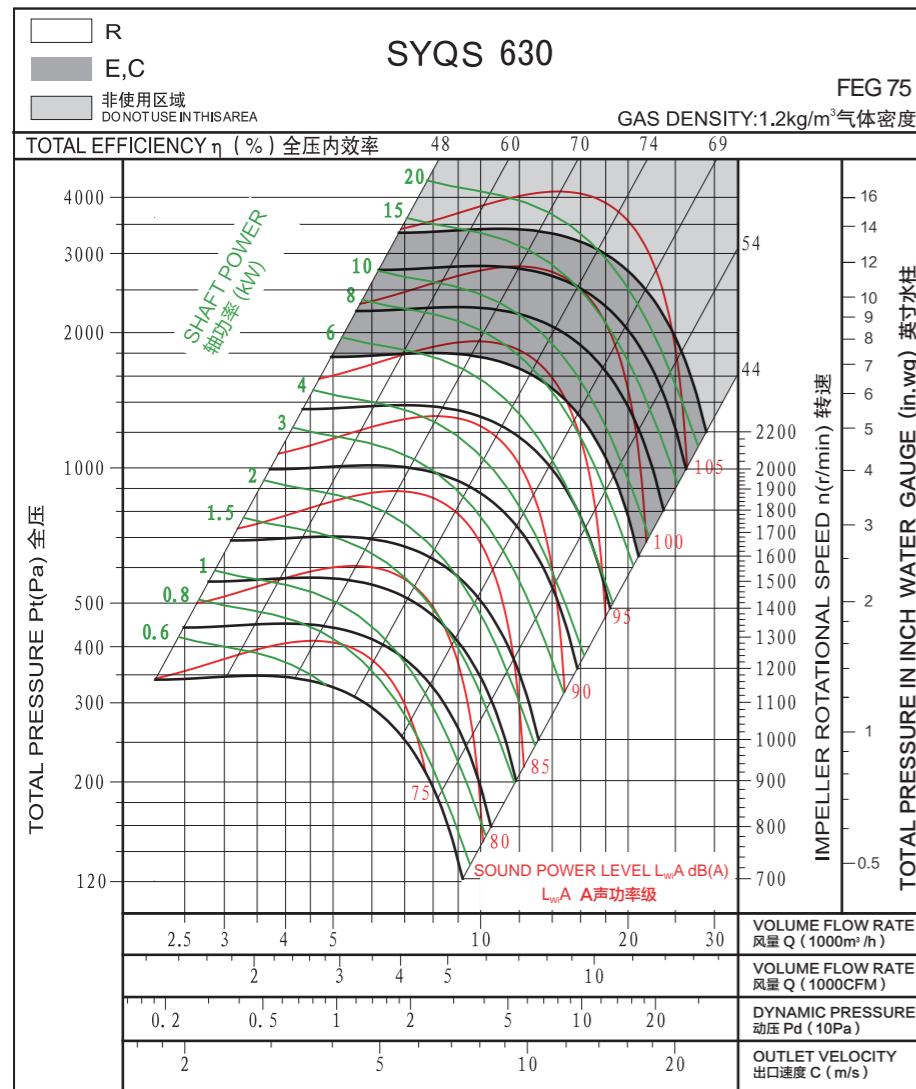

Measured in installation B according to AMCA Standard 210:

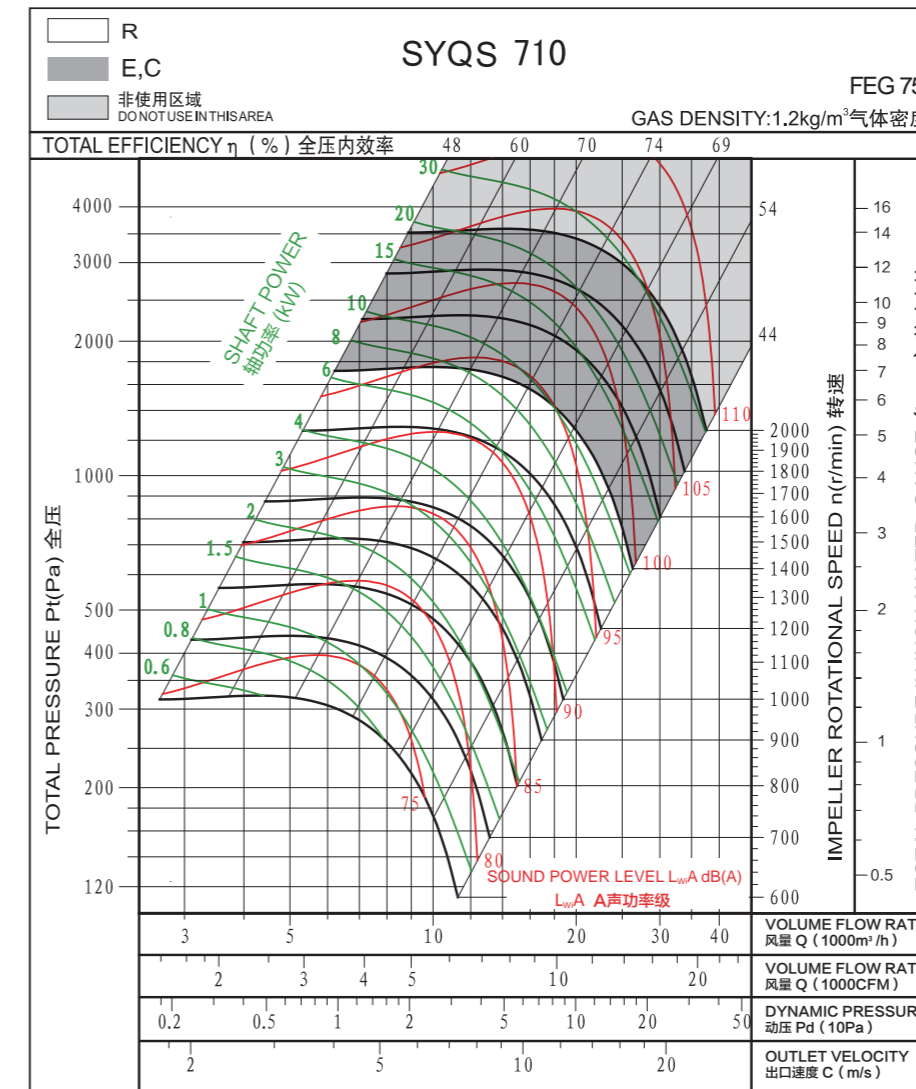
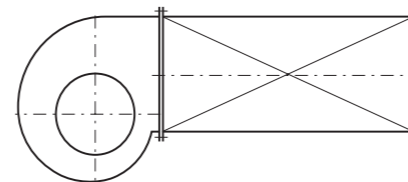

Measured in installation B according to AMCA Standard 210:

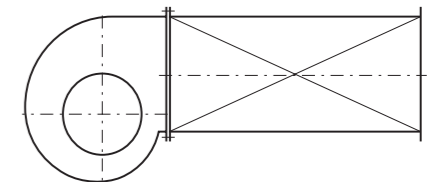

## 技术参数

## Technical Data

Wheel diameter 叶轮直径	D = 800 mm	Fan weight 风机质量	m =245 kg
Moment of inertia 转动惯量	J = 5.09kg·m <sup>2</sup>	Speed limit 极限转速	n <sub>max</sub> =1400 r/min

## 技术参数

## Technical Data

Wheel diameter 叶轮直径	D = 900 mm	Fan weight 风机质量	m =350 kg
Moment of inertia 转动惯量	J = 7.59kg·m <sup>2</sup>	Speed limit 极限转速	n <sub>max</sub> =1400 r/min

## 性能曲线

## Performance Curve

经认证的性能是B类安装：自由入口，管道出口。功率额定值(kW)不包括传输损失。各项性能额定值不包括附属物(附件)的影响。所示A加权声音性能额定值已按AMCA International标准301计算。所示值为安装类型B：自由入口，管道出口的声功率级（入口L<sub>WA</sub>）。

Performance certified is for installation type B: free inlet, ducted outlet. Power rating (kW) does not include transmission losses. Performance ratings do not include the effects of appurtenances (accessories). The A-weighted sound ratings shown have been calculated per AMCA International Standard 301. Values shown are for inlet L<sub>WA</sub> sound power levels for installation type B: free inlet, ducted outlet.

## 性能曲线

## Performance Curve

经认证的性能是B类安装：自由入口，管道出口。功率额定值(kW)不包括传输损失。各项性能额定值不包括附属物(附件)的影响。所示A加权声音性能额定值已按AMCA International标准301计算。所示值为安装类型B：自由入口，管道出口的声功率级（入口L<sub>WA</sub>）。

Performance certified is for installation type B: free inlet, ducted outlet. Power rating (kW) does not include transmission losses. Performance ratings do not include the effects of appurtenances (accessories). The A-weighted sound ratings shown have been calculated per AMCA International Standard 301. Values shown are for inlet L<sub>WA</sub> sound power levels for installation type B: free inlet, ducted outlet.

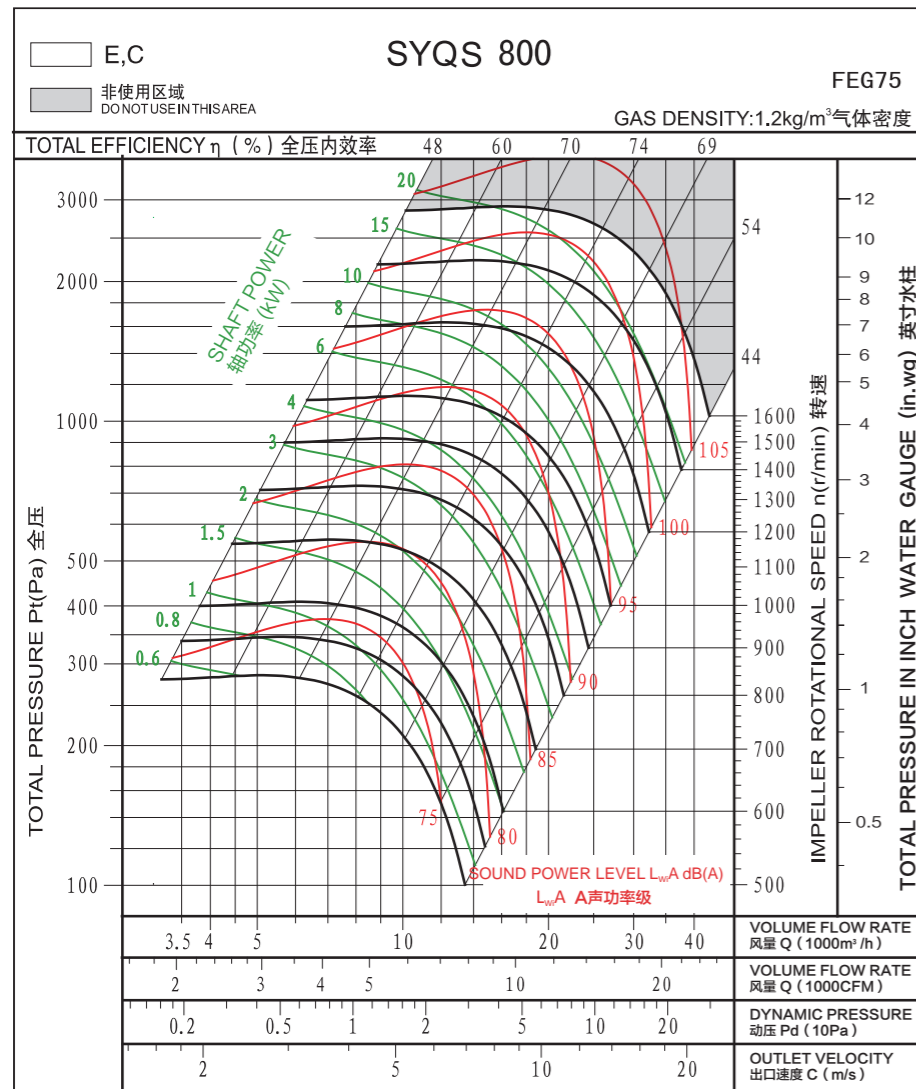

Measured in installation B according to AMCA Standard 210:

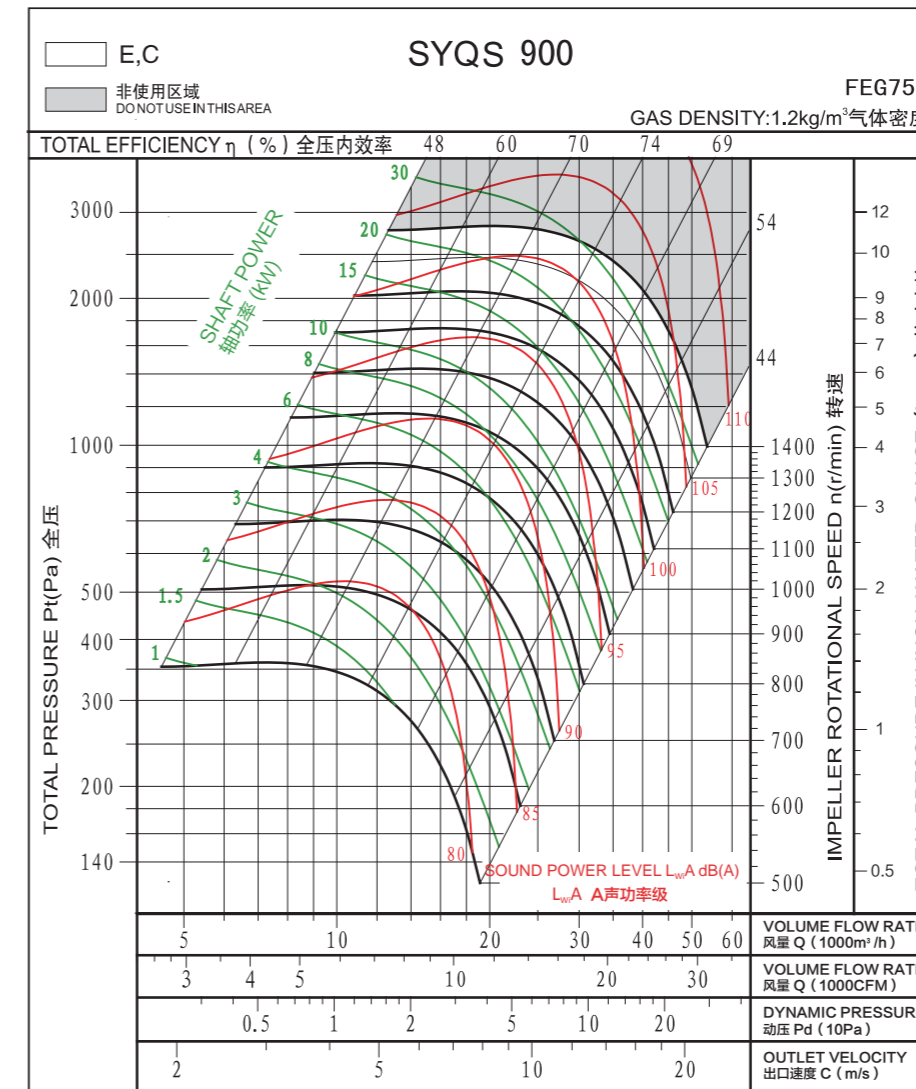
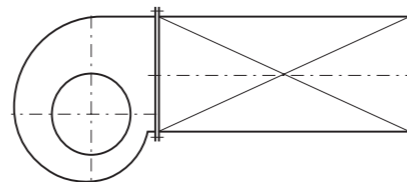

Measured in installation B according to AMCA Standard 210:

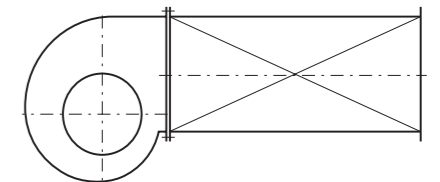



## 技术参数

## Technical Data

Wheel diameter 叶轮直径	D = 1000 mm	Fan weight 风机质量	m = 435 kg
Moment of inertia 转动惯量	J = 13.64kg·m <sup>2</sup>	Speed limit 极限转速	n <sub>max</sub> = 1400 r/min

## 技术参数

## Technical Data

Wheel diameter 叶轮直径	D = 1120 mm	Fan weight 风机质量	m = 600 kg
Moment of inertia 转动惯量	J = 23.93kg·m <sup>2</sup>	Speed limit 极限转速	n <sub>max</sub> = 1300 r/min

## 性能曲线

## Performance Curve

经认证的性能是B类安装：自由入口，管道出口。功率额定值(kW)不包括传输损失。各项性能额定值不包括附属物(附件)的影响。所示A加权声音性能额定值已按AMCA International标准301计算。所示值为安装类型B：自由入口，管道出口的声功率级（入口L<sub>WA</sub>）。

Performance certified is for installation type B: free inlet, ducted outlet. Power rating (kW) does not include transmission losses. Performance ratings do not include the effects of appurtenances (accessories). The A-weighted sound ratings shown have been calculated per AMCA International Standard 301. Values shown are for inlet L<sub>WA</sub> sound power levels for installation type B: free inlet, ducted outlet.

## 性能曲线

## Performance Curve

经认证的性能是B类安装：自由入口，管道出口。功率额定值(kW)不包括传输损失。各项性能额定值不包括附属物(附件)的影响。所示A加权声音性能额定值已按AMCA International标准301计算。所示值为安装类型B：自由入口，管道出口的声功率级（入口L<sub>WA</sub>）。

Performance certified is for installation type B: free inlet, ducted outlet. Power rating (kW) does not include transmission losses. Performance ratings do not include the effects of appurtenances (accessories). The A-weighted sound ratings shown have been calculated per AMCA International Standard 301. Values shown are for inlet L<sub>WA</sub> sound power levels for installation type B: free inlet, ducted outlet.

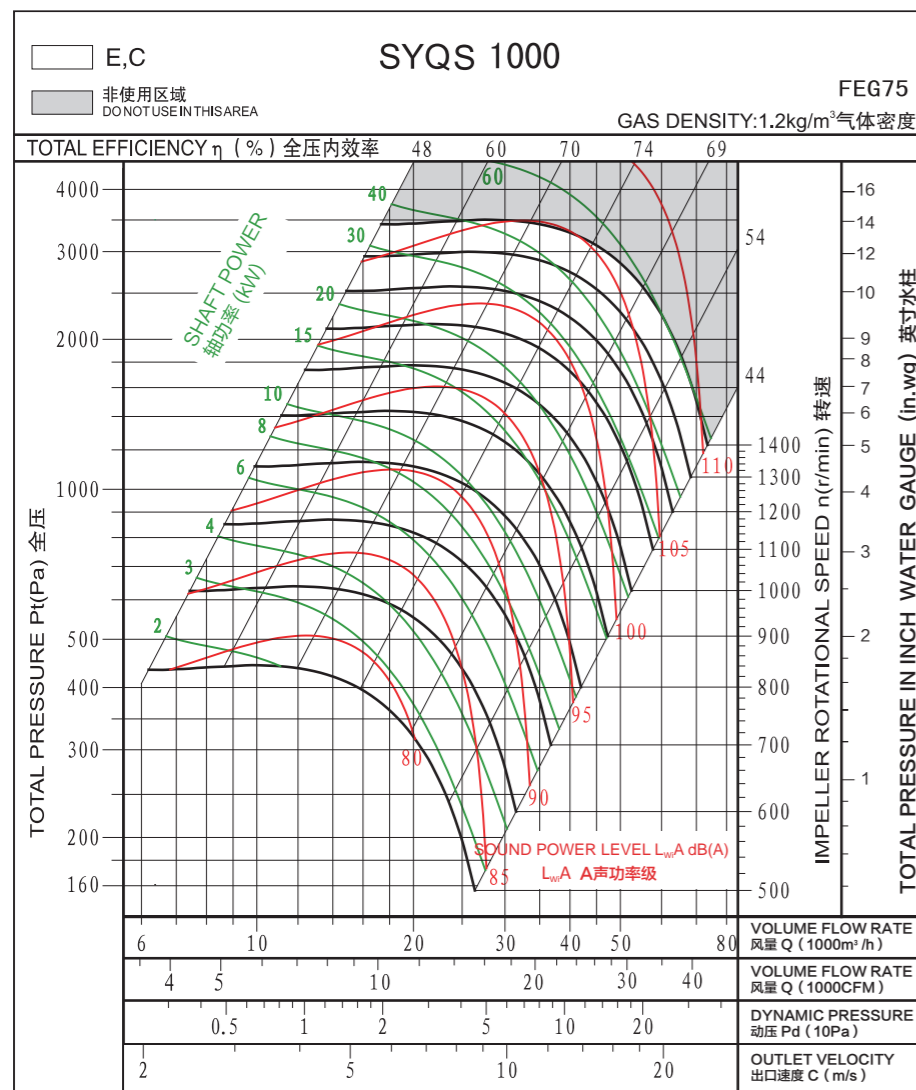

Measured in installation B according to AMCA Standard 210:

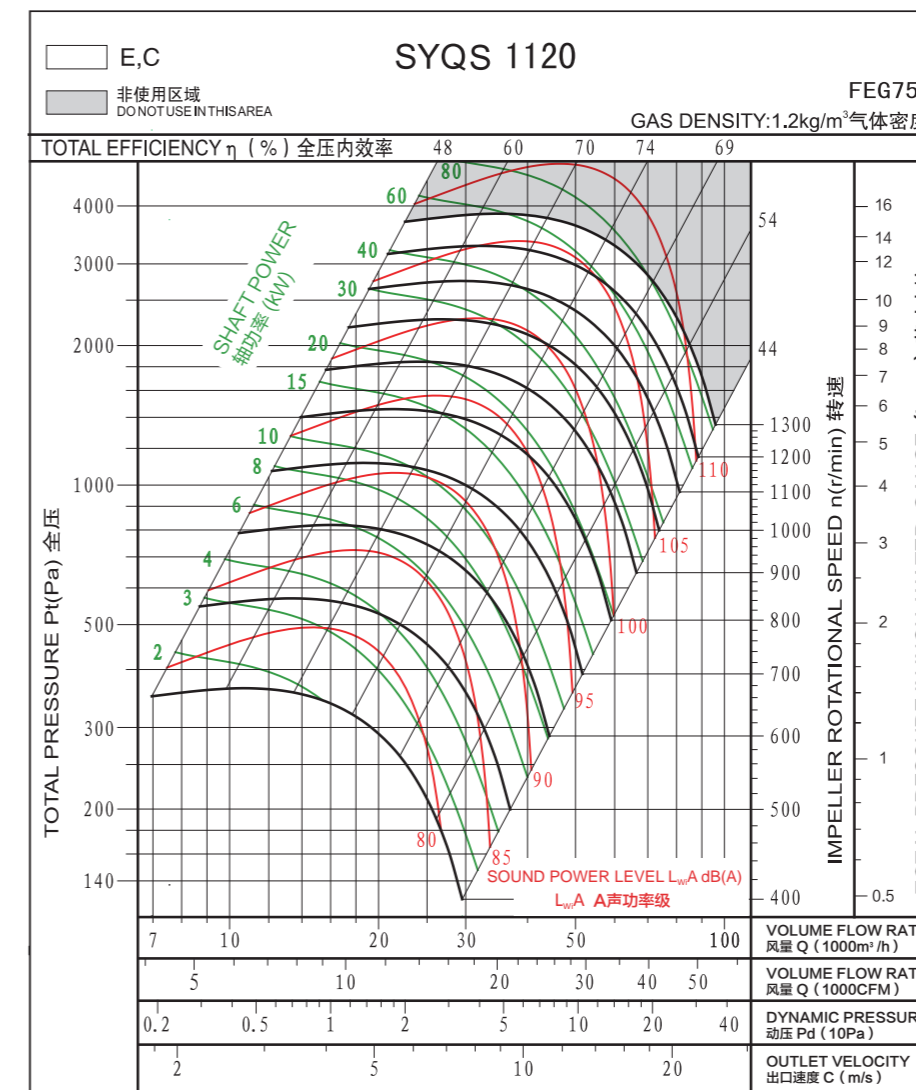
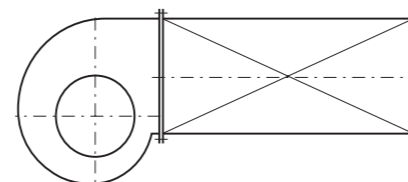

Measured in installation B according to AMCA Standard 210:

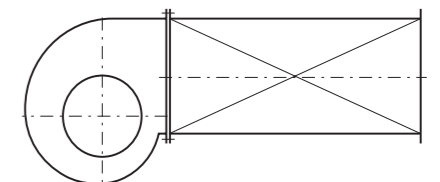

## 技术参数

## Technical Data

Wheel diameter 叶轮直径	D = 1250 mm	Fan weight 风机质量	m = 790 kg
Moment of inertia 转动惯量	J = 41.7 kg·m <sup>2</sup>	Speed limit 极限转速	n <sub>max</sub> = 1200 r/min

## 技术参数

## Technical Data

Wheel diameter 叶轮直径	D = 1400 mm	Fan weight 风机质量	m = 1080 kg
Moment of inertia 转动惯量	J = 77.4 kg·m <sup>2</sup>	Speed limit 极限转速	n <sub>max</sub> = 1000 r/min

## 性能曲线

## Performance Curve

经认证的性能是B类安装：自由入口，管道出口。功率额定值(kW)不包括传输损失。各项性能额定值不包括附属物(附件)的影响。所示A加权声音性能额定值已按AMCA International标准301计算。所示值为安装类型B：自由入口，管道出口的声功率级（入口L<sub>WA</sub>）。

Performance certified is for installation type B: free inlet, ducted outlet. Power rating (kW) does not include transmission losses. Performance ratings do not include the effects of appurtenances (accessories). The A-weighted sound ratings shown have been calculated per AMCA International Standard 301. Values shown are for inlet L<sub>WA</sub> sound power levels for installation type B: free inlet, ducted outlet.

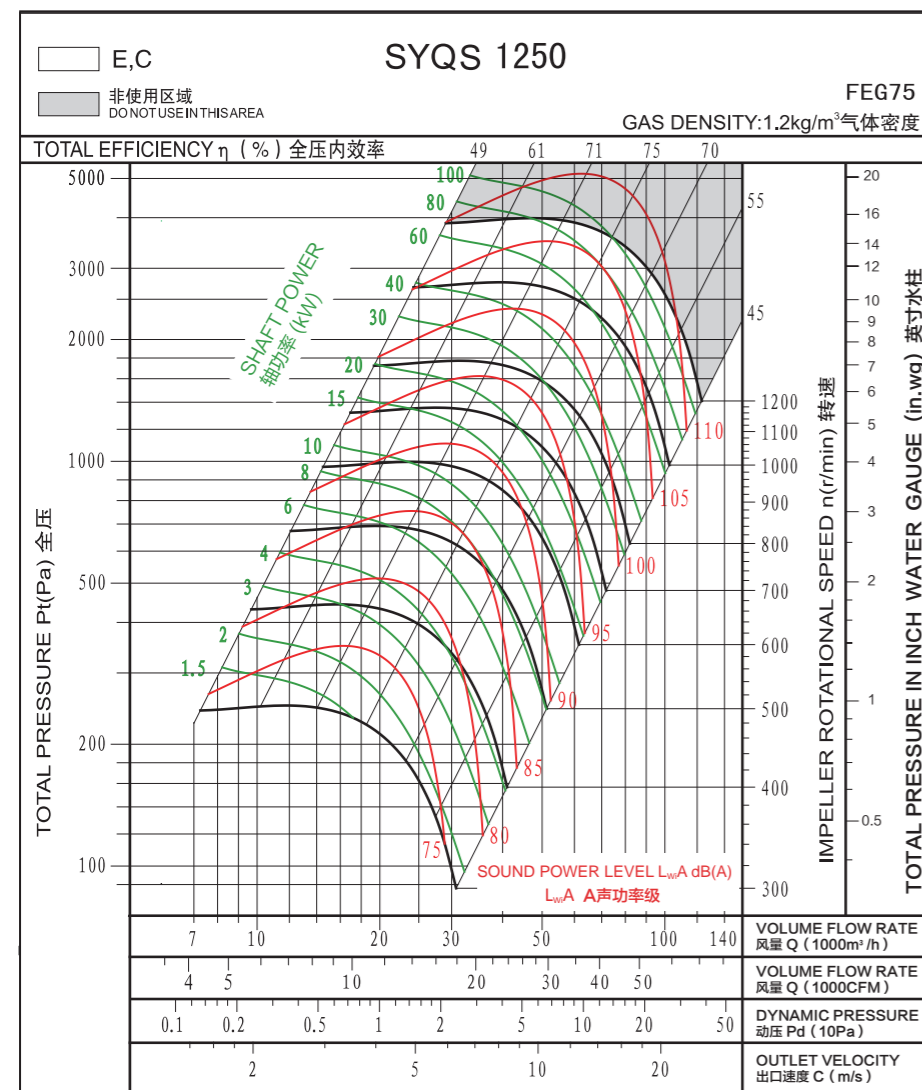

## 性能曲线

## Performance Curve

经认证的性能是B类安装：自由入口，管道出口。功率额定值(kW)不包括传输损失。各项性能额定值不包括附属物(附件)的影响。所示A加权声音性能额定值已按AMCA International标准301计算。所示值为安装类型B：自由入口，管道出口的声功率级（入口L<sub>WA</sub>）。

Performance certified is for installation type B: free inlet, ducted outlet. Power rating (kW) does not include transmission losses. Performance ratings do not include the effects of appurtenances (accessories). The A-weighted sound ratings shown have been calculated per AMCA International Standard 301. Values shown are for inlet L<sub>WA</sub> sound power levels for installation type B: free inlet, ducted outlet.

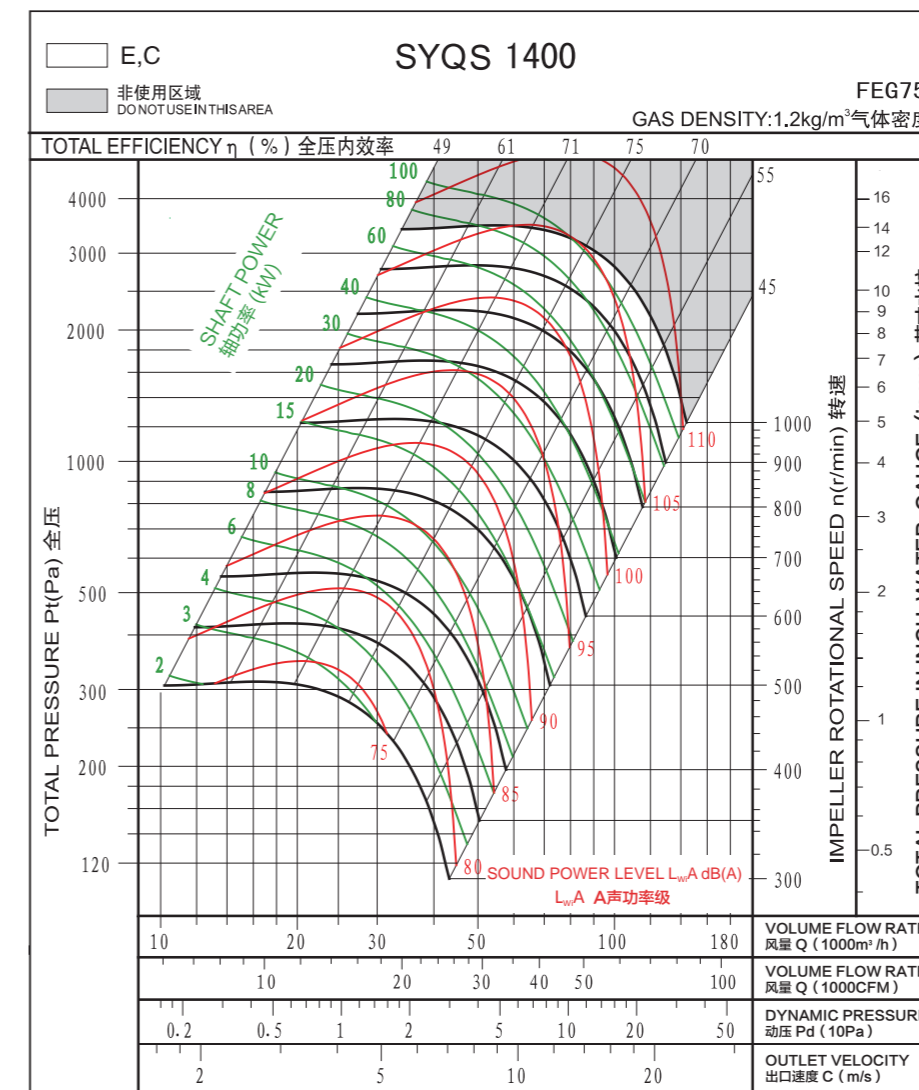

出口法兰

Outlet Flange

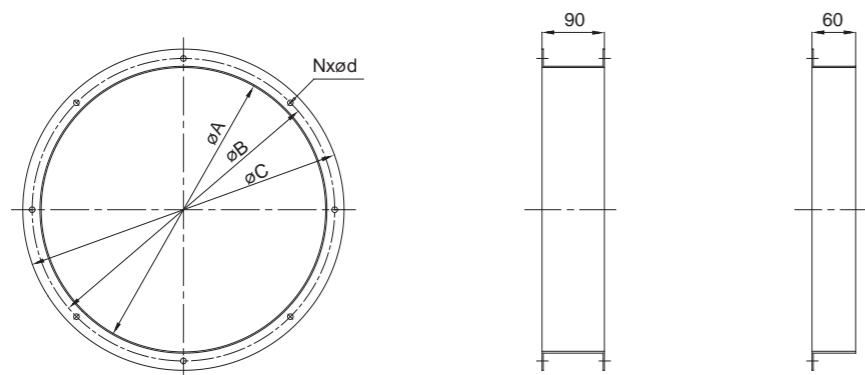

单位: mm

Model Dim	280	315	355	400	450	500	560	630	710	800	900	1000	1120	1250	1400
A	292	322	362	404	448	510	570	635	722	808	896	996	1130	1264	1404
B	325	344	386	432	485	544	605	670	750	844	945	1044	1180	1310	1450
C	355	383	423	466	515	570	635	700	778	875	980	1080	1226	1360	1500
N-d	6x7	6x7	8x9	8x9	8x9	8x11	8x11	10x13	10x13	12x13	12x13	12x13	12x15	16x17	16x17

出口法兰

Outlet Flange

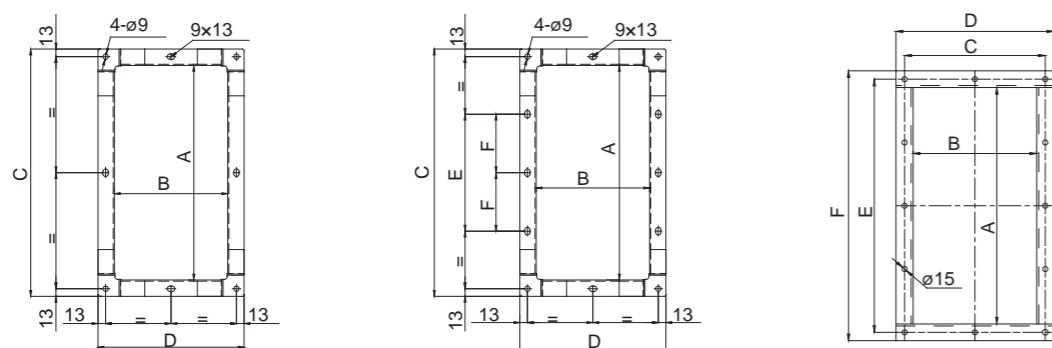

单位: mm

Model Dim	280	315	355	400	450	500	560	630	710	800	900	1000	1120	1250	1400
A	361	404	453	507	569	638	715	801	898	1007	1130	1267	725	800	902
B	197	223	237	257	308	344	383	432	478	533	595	663	1426	1588	1776
C	417	460	509	563	625	684	771	857	954	1063	1186	1323	777	850	952
D	253	279	294	330	364	400	439	488	534	589	651	719	825	900	1002
E	\	\	\	200	200	250	250	300	400	500	600	700	1478	1638	1826
F	\	\	\	\	\	\	\	\	200	250	300	350	1526	1688	1876

SYQS-R

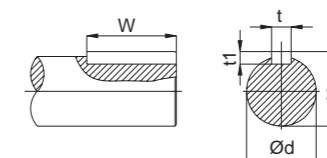
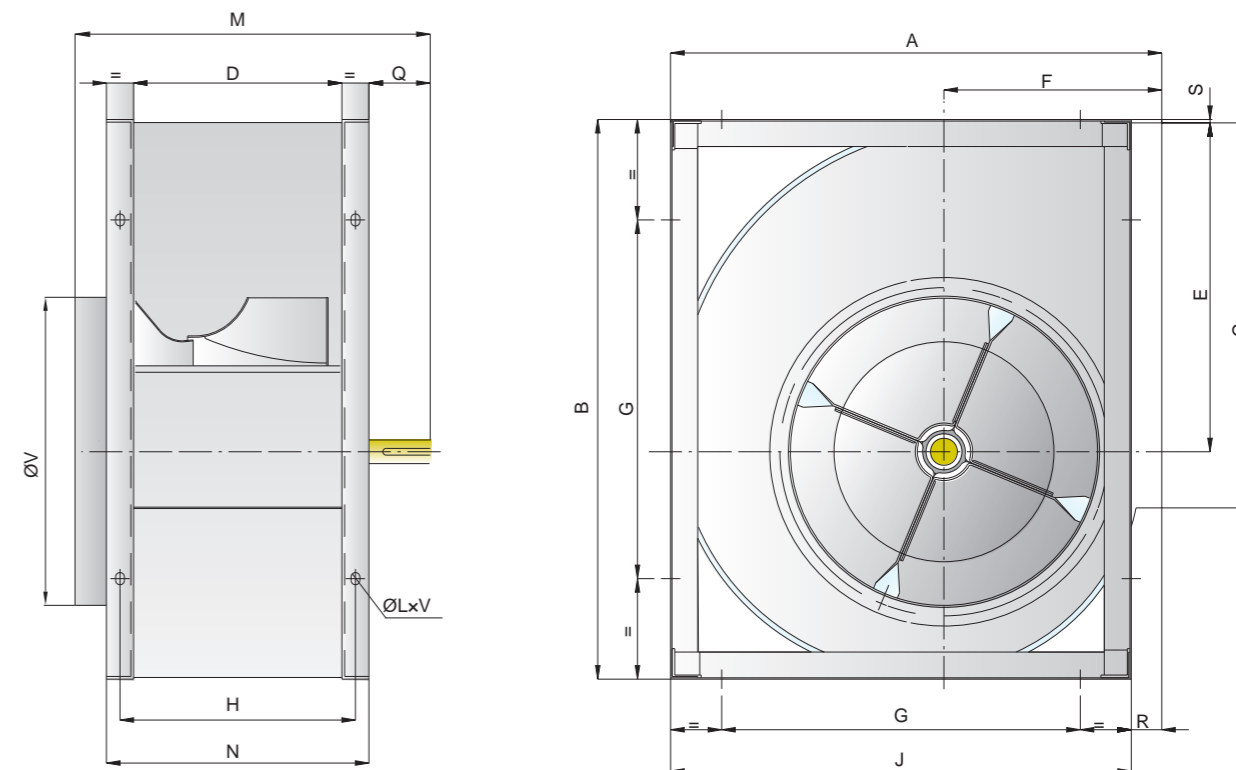

单位: mm

Model Dim	A	B	C	D	E	F	G	H	J	K	M	N	Q	R	S	V	t	t <sub>1</sub>	W	X	$\phi d$	LxV
280	466	518	361	197	302	215	280	227	432	30	360	257	73	34	5	292	8	7	50	28	25	13x18
315	518	578	404	223	340	236	280	253	480	30	395	283	83	38	3	322	8	7	60	28	25	13x18
355	578	655	453	247	383	261	355	287	548	40	425	327	78	30	6	362	8	7	60	33	30	13x18
400	651	736	507	274	431.5	290	355	314	613	40	452	354	78	38	4.5	404	8	7	60	33	30	13x18
450	726	827	569	308	486	322	530	348	681	40	500	388	92	45	5	448	10	8	70	38	35	13x18
500	800	918	638	344	538	352	530	394	750	40	535	424	92	50	5	510	10	8	70	38	35	13x18
560	893	1030	715	383	602	390	530	433	845	50	600	483	87	48	8	570	12	8	70	43	40	13x18
630	999	1157	801	432	678.5	434	530	482	946	50	650	532	87	53	7	635	14	9	70	48.5	45	13x18
710	1121	1303	898	478	765	485	630	528	1058	50	725	578	115	63	7	722	14	9	90	48.5	50	17x22



SYQS-E

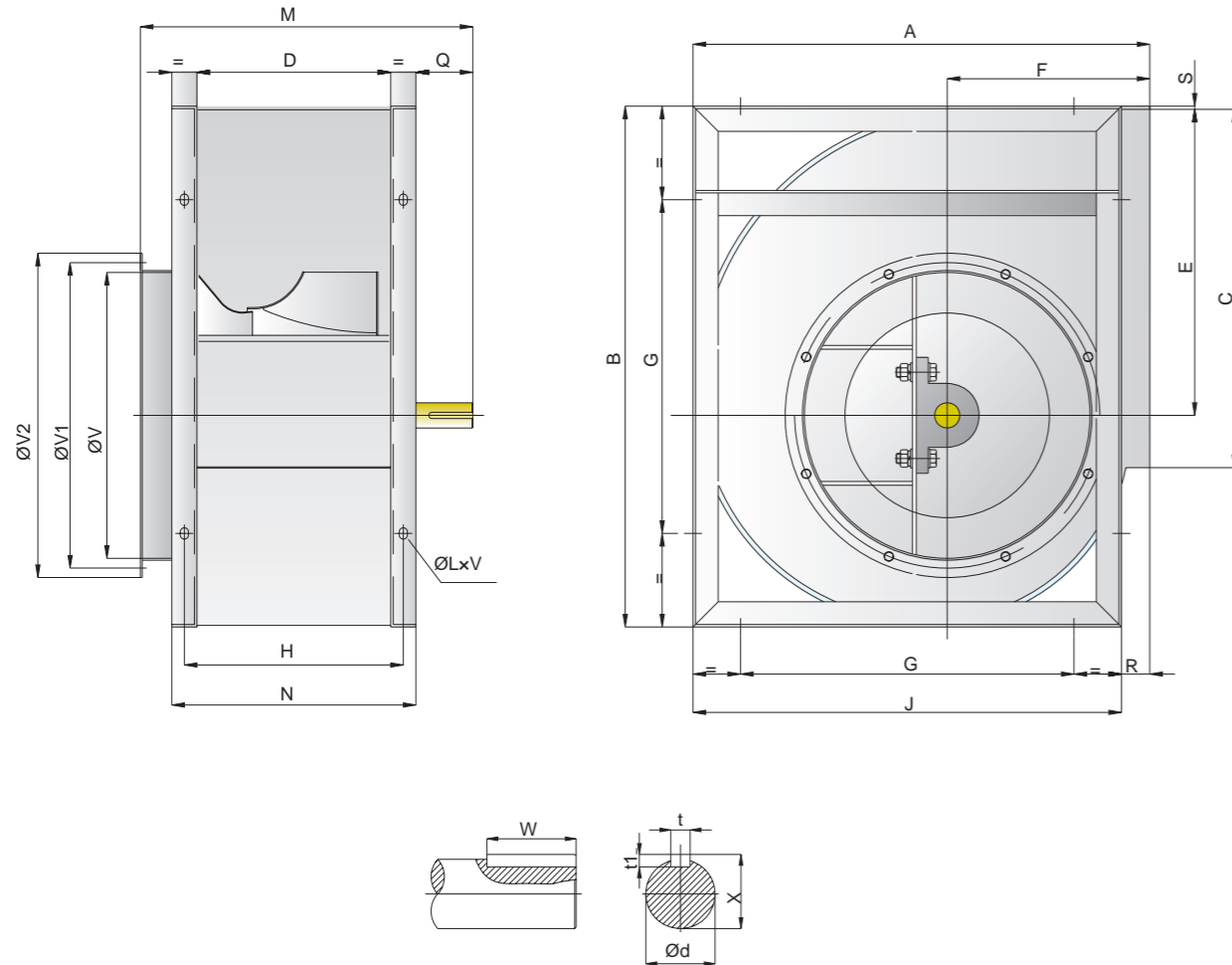

单位: mm

Model Dim	A	B	C	D	E	F	G	H	J	K	M	N	Q	R	S	V	V1	V2	t	t1	W	X	Φd	LxV
280	466	518	361	197	302	215	280	227	432	30	405	257	86	34	5	292	325	355	8	7	60	33	30	13x18
315	518	578	404	223	340	236	280	253	480	30	440	283	96	38	3	322	344	383	8	7	70	33	30	13x18
355	578	655	453	247	383	261	355	287	548	40	470	327	91	30	6	362	386	423	10	8	70	38	35	13x18
400	651	736	507	274	431.5	290	355	314	613	40	497	354	91	38	4.5	404	432	466	10	8	70	38	35	13x18
450	726	827	569	308	486	322	530	348	681	40	556	388	116	45	5	448	485	515	12	8	90	43	40	13x18
500	800	918	638	344	538	352	530	394	750	40	592	424	116	50	5	510	544	570	12	8	90	43	40	13x18
560	893	1030	715	383	602	390	530	433	845	50	640	483	115	48	8	570	605	635	14	9	90	53.5	50	13x18
630	999	1157	801	432	678.5	434	530	482	946	50	690	532	115	53	7	635	670	700	14	9	90	53.5	50	13x18
710	1121	1303	898	478	765	485	630	528	1058	50	746	578	126	63	7	722	750	778	18	11	90	64	60	17x22
800	1250	1468	1107	533	862	535	710	583	1181	50	801	633	126	69	7	808	844	875	18	11	90	64	60	17x22
900	1408	1648	1130	595	971	604	800	655	1319	60	880	715	135	89	7	896	945	980	18	11	100	69	65	17x22
1000	1541	1810	1267	663	1066	657	900	713	1462	60	950	783	135	79	9	996	1044	1080	18	11	100	69	65	17x22

SYQS-E

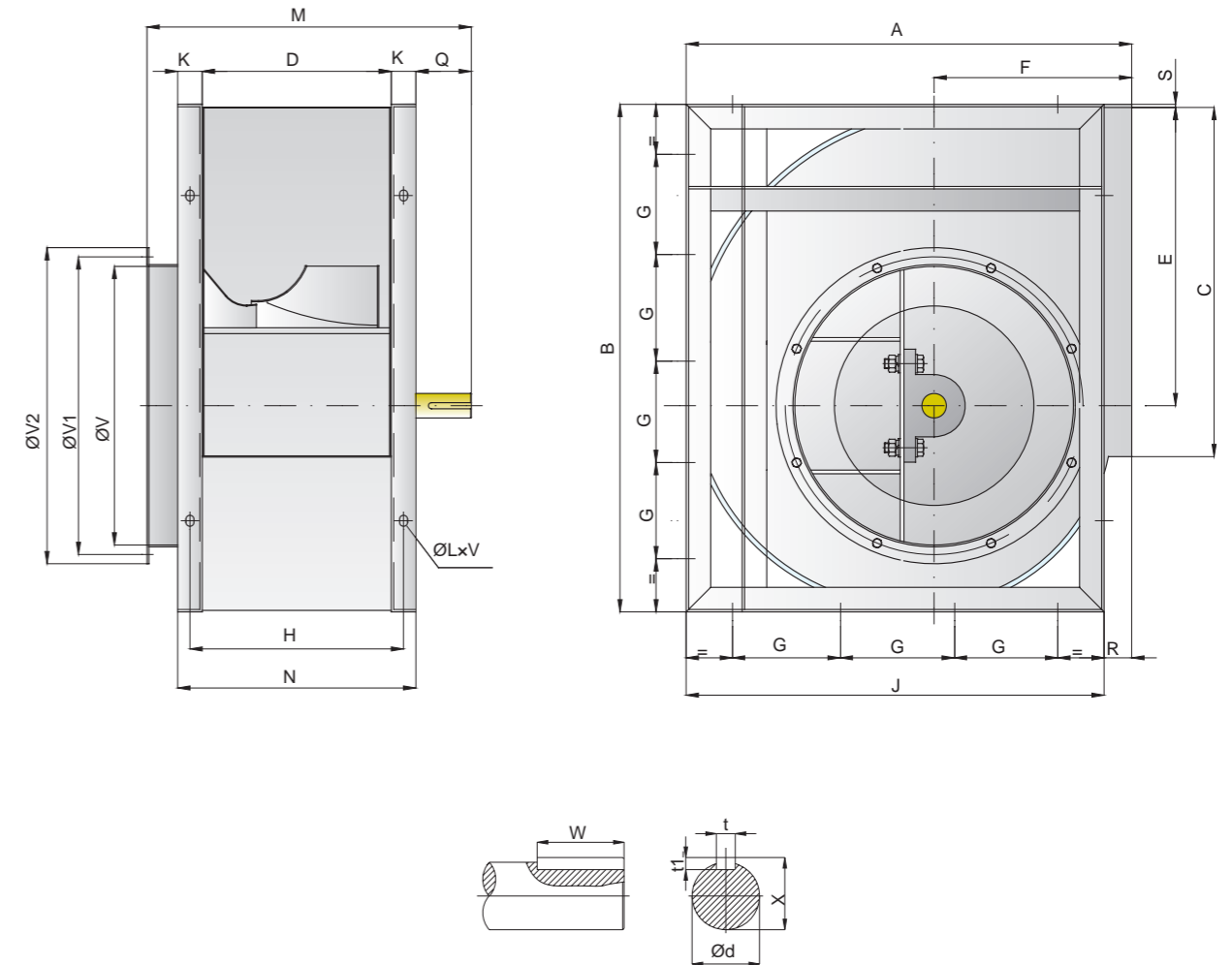

单位: mm

Model Dim	A	B	C	D	E	F	G	H	J	K	M	N	Q	R	S	V	V1	V2	t	t1	W	X	Φd	LxV
1120	1748	2033	1421	722	1192	758	400	782	1630	60	1135	842	247	188	11	1130	1181	1266	18	11	140	69	65	17x22
1250	1950	2270	1588	800	1333	840	450	880	1825	75	1218	950	235	125	12	1265	1361	1361	20	12	140	74.5	70	17x22
1400	2160	2535	1744	900	1492	920	500	980	2050	75	1337	1050	255	110	10	1402	1450	1500	22	14	140	85	80	17x22

SYQS-C

SYQS-C

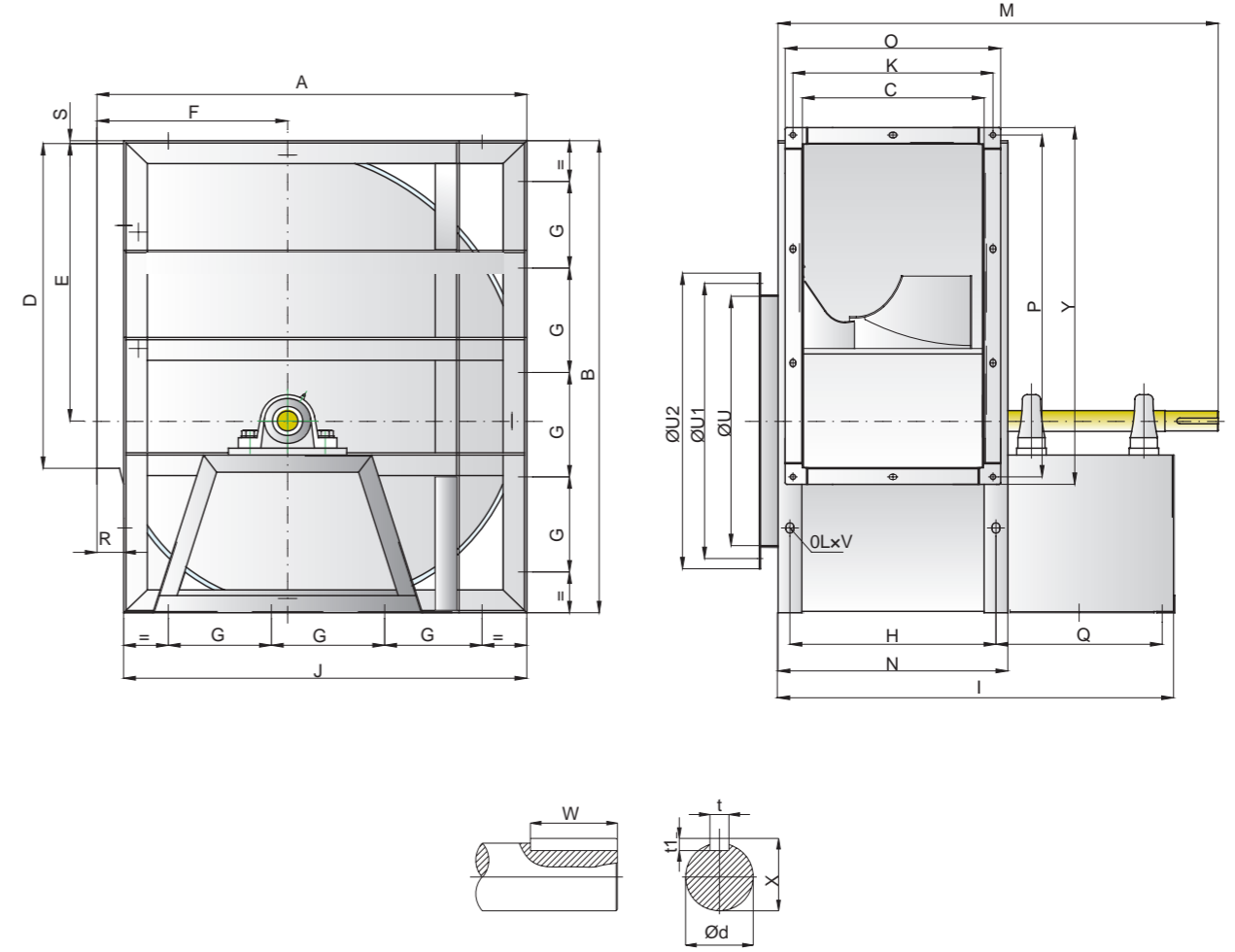
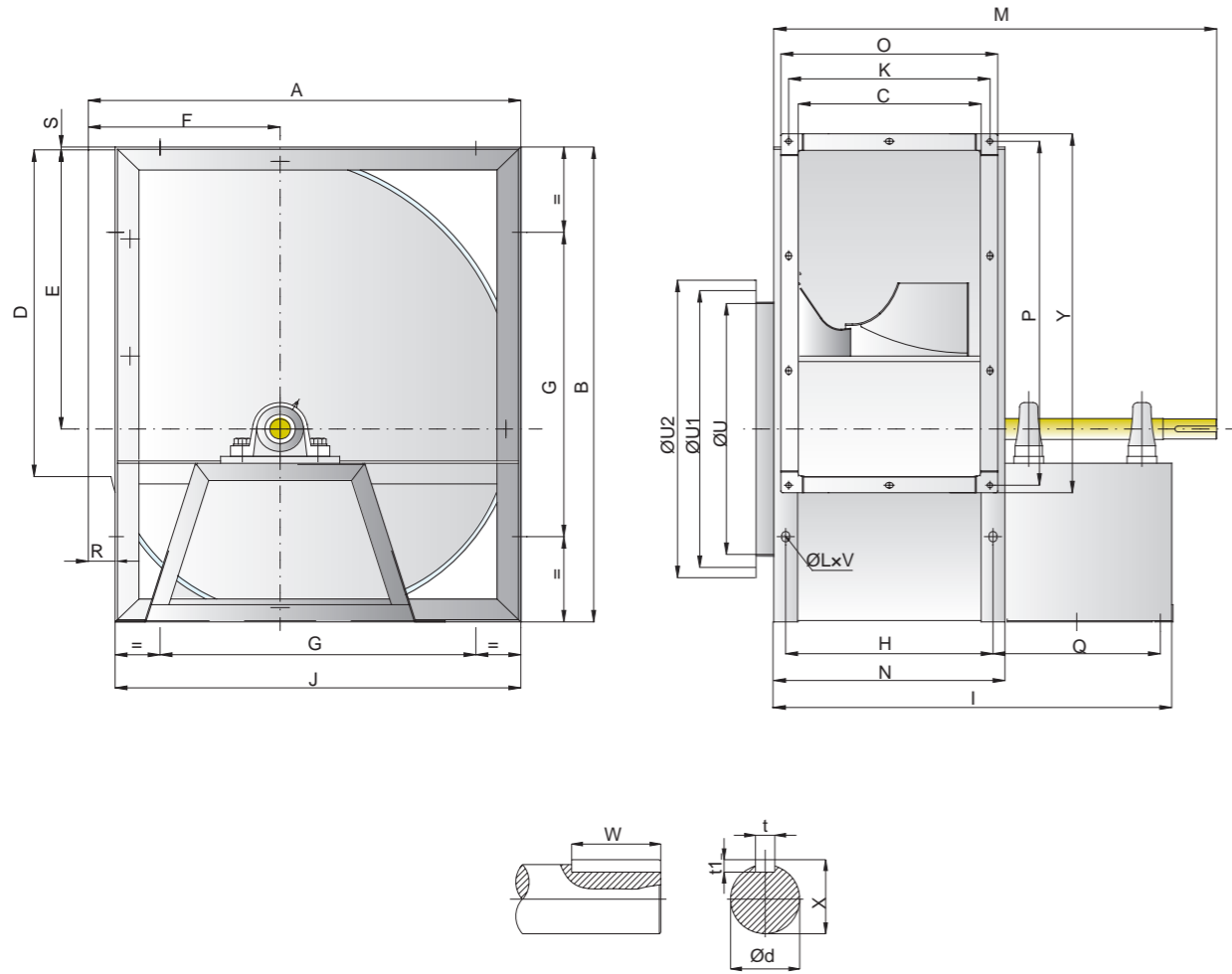

单位: mm

单位: mm

Model Size	A	B	C	D	E	F	G	H	I	J	K	M	N	O	P	Q	R	S	t	t1	U	U1	U2	W	X	Y	Φd	LxV
280	466	518	197	361	302	215	280	227	530	432	213	590	257	239	391	274	34	5	8	7	292	325	355	40	28	417	25	13x18
315	518	578	223	404	340	236	280	253	556	480	233	612	283	259	434	274	38	3	8	7	322	344	383	40	28	460	25	13x18
355	578	655	247	453	383	261	355	287	627	548	260	697	327	286	483	300	30	6	8	7	362	386	423	50	33	509	30	13x18
400	651	736	274	507	432	290	355	314	654	613	290	724	354	316	537	300	38	4.5	8	7	404	432	466	50	33	563	30	13x18
450	726	827	308	569	486	322	530	348	728	681	318	816	388	344	599	340	45	5	10	8	448	485	515	70	38	625	35	13x18
500	800	918	344	638	538	352	530	384	764	750	350	850	424	376	668	340	50	5	10	8	510	544	570	70	38	694	35	13x18
560	893	1030	383	715	603	390	530	433	855	845	366	945	483	414	745	378	48	8	12	8	570	605	635	90	43	771	40	13x18
630	999	1157	432	801	679	434	530	482	904	946	434	994	532	460	831	378	53	7	12	8	635	670	700	90	43	857	40	13x18
710	1121	1303	478	898	765	485	630	528	1005	1058	483	1115	578	512	928	436	63	7	14	9	722	750	778	90	48.5	954	45	17x22
800	1250	1468	533	1107	862	535	710	583	1060	1181	541	1170	633	567	1039	440	69	7	14	9	808	844	875	90	48.5	1063	45	17x22
900	1408	1648	595	1130	971	604	800	655	1191	1319	602	1313	715	613	1160	510	89	7	16	10	896	945	980	100	58.5	1186	45	17x22
1000	1541	1810	663	1267	1066	657	900	713	1259	1462	668	1381	783	694	1297	510	79	9	16	10	996	1044	1080	100	58.5	1323	45	17x22

Model Size	A	B	C	D	E	F	G	H	I	J	K	M	N	O	P	Q	R	S	t	t1	U	U1	U2	W	X	Y	Φd	LxV
1120	1748	2033	722	1421	1192	758	400	782	1397	1630	777	1583	842	825	1478	572	118	11	18	11	1130	1180	1266	120	69	1526	65	17x22
1250	1950	2270	800	1588	1333	840	450	880	1565	1825	850	1740	950	900	1638	600	125	12	20	12	1265	1310	1361	140	74.5	1688	70	17x22
1400	2160	2535	900	1744	1492	920	500	980	1760	2050	952	1910	1050	1002	1826	695	110	10	22	14	1402	1450	1500	140	85	1876	80	17x22

SYQS-C

		0°				90°				180°			
左旋 LG Left Hand													
右旋 RD Right Hand													
型号	电机	L	A	B	C	L	A	B	C	L	A	B	C
280	80	425	760	675	568	375	850	675	516	410	760	675	568
	90	435	780	675	568	385	860	675	516	420	780	675	568
	100	445	800	675	568	395	880	675	516	430	800	675	568
	112	455	850	675	568	405	930	675	516	440	850	675	568
	132	465	870	675	568	415	950	675	516	450	870	675	568
315	80	465	800	700	628	405	900	700	568	440	800	700	628
	90	475	820	700	628	415	920	700	568	450	820	700	628
	100	485	850	700	628	425	950	700	568	460	850	700	628
	112	495	900	700	628	435	1000	700	568	470	900	700	628
	132	505	920	700	628	445	1020	700	568	480	920	700	628
355	80	515	850	775	705	445	1000	775	628	480	850	775	705
	90	525	860	775	705	455	1000	775	628	490	860	775	705
	100	535	900	775	705	465	1040	775	628	500	900	775	705
	112	545	960	775	705	475	1080	775	628	510	960	775	705
	132	555	980	775	705	485	1100	775	628	520	980	775	705
400	90	585	930	800	786	500	950	800	701	540	930	800	786
	100	595	980	800	786	510	1000	800	701	550	980	800	786
	112	605	1030	800	786	520	1160	800	701	560	1030	800	786
	132	615	1050	800	786	530	1180	800	701	570	1050	800	786
	160	615	1100	800	786	530	1230	800	701	570	1100	800	786
450	90	650	1000	894	877	548	1120	894	776	590	1000	894	877
	100	660	1050	894	877	558	1170	894	776	600	1050	894	877
	112	670	1100	894	877	568	1220	894	776	610	1100	894	877
	132	680	1120	894	877	578	1270	894	776	620	1120	894	877
	160	680	1200	894	877	578	1350	894	776	620	1200	894	877
500	90	720	1100	930	968	610	1250	930	850	650	1100	930	968
	100	730	1130	930	968	620	1280	930	850	660	1130	930	968
	112	740	1180	930	968	630	1330	930	850	670	1180	930	968
	132	750	1200	930	968	640	1350	930	850	680	1200	930	968
	160	750	1280	930	968	640	1440	930	850	680	1280	930	968
560	100	805	1210	1020	1093	680	1370	1020	956	720	1210	1020	1093
	112	815	1260	1020	1093	690	1420	1020	956	730	1260	1020	1093
	132	825	1280	1020	1093	700	1460	1020	956	740	1280	1020	1093
	160	835	1360	1020	1093	710	1540	1020	956	750	1360	1020	1093
	180	845	1400	1020	1093	720	1580	1020	956	760	1400	1020	1093
630	100	895	1310	1065	1220	755	1530	1065	1062	795	1310	1065	1220
	112	905	1360	1065	1220	765	1580	1065	1062	805	1360	1065	1220
	132	915	1380	1065	1220	775	1600	1065	1062	815	1380	1065	1220
	160	930	1450	1065	1220	790	1680	1065	1062	830	1450	1065	1220
	180	940	1500	1065	1220	800	1730	1065	1062	840	1500	1065	1220
200	950	1550	1065	1220	810	1780	1065	1062	850	1550	1065	1220	

SYQS-C

		0°				90°				180°			
左旋 LG Left Hand													
右旋 RD Right Hand													
型号	电机	L	A	B	C	L	A	B	C	L	A	B	C
710	100	1005	1430	1185	1366	840	1670	1185	1184	885	1430	1185	1366
	112	1015	1480	1185	1366	850	1720	1185	1184	895	1480	1185	1366
	132	1025	1500	1185	1366	860	1740	1185	1184	905	1500	1185	1366
	160	1040	1570	1185	1366	875	1800	1185	1184	920	1570	1185	1366
	180	1050	1620	1185	1366	885	1850	1185	1184	930	1620	1185	1366
	200	1060	1670	1185	1366	895	1900	1185	1184	940	1670	1185	1366
225	1070	1700	1185	1366	905	1930	1185	1184	950	1700	1185	1366	
800	112	1130	1580	1245	1548	950	1880	1245	1330	990	1580	1245	1548
	132	1140	1600	1245	1548	960	1900	1245	1330	1000	1600	1245	1548
	160	1155	1650	1245	1548	975	1950	1245	1330	1015	1650	1245	1548
	180	1165	1720	1245	1548	985	2020	1245	1330	1025	1720	1245	1548
	200	1175	1770	1245	1548	995	2070	1245	1330	1035	1770	1245	1548
	225	1185	1820	1245	1548	1005	2120	1245	1330	1045	1820	1245	1548
250	1195	1880	1245	1548	1015	2180	1245	1330	1055	1880	1245	1548	
900	112	1270	1730	1375	1728	1060	2060	1375	1488	1110	1730	1375	1728
	132	1280	1750	1375	1728	1070	2080	1375	1488	1110	1750	1375	1728
	160	1295	1800	1375	1728	1085	2130	1375	1488	1125	1800	1375	1728
	180	1310	1880	1375	1728	1095	2220	1375	1488	1135	1880	1375	1728
	200	1320	1920	1375	1728	1105	2250	1375	1488	1145	1920	1375	1728
	225	1330	1980	1375	1728	1115	2320	1375	1488	1155	1980	1375	1728
250	1340	2050	1375	1728	1125	2380	1375	1488	1165	2050	1375	1728	
1000	132	1400	1900	1450	1890	1175	2250	1450	1621	1215	1900	1450	1890
	160	1415	1950	1450	1890	1190	2300	1450	1621	1230	1950	1450	1890
	180	1425	2030	1450	1890	1200	2380	1450	1621	1240	2030	1450	1890
	200	1435	2070	1450	1890	1210	2420	1450	1621	1250	2070	1450	1890
	225	1445	2130	1450	1890	1220	2480	1450	1621	1260	2130	1450	1890
	250	1455	2200	1450	1890	1230	2550	1450	1621	1270	2200	1450	1890
280	1465	2250	1450	1890	1240	2600	1450	1621	1280	2250	1450	1890	



SYQS-E

		0°				90°				180°			
左旋 LG Left Hand													
右旋 RD Right Hand													
型号	电机	L	A	B	C	L	A	B	C	L	A	B	C
280	80	425	760	430	568	375	850	430	516	410	760	430	568
	90	435	780	430	568	385	860	430	516	420	780	430	568
	100	445	800	430	568	395	880	430	516	430	800	430	568
	112	455	850	430	568	405	930	430	516	440	850	430	568
315	80	465	800	465	628	405	900	465	568	440	800	465	628
	90	475	820	465	627	415	920	465	568	450	820	465	627
	100	485	850	465	628	425	950	465	568	460	850	465	628
	112	495	900	465	628	435	1000	465	568	470	900	465	628
355	80	515	850	495	705	445	1000	495	628	480	850	495	705
	90	525	860	495	705	455	1000	495	628	490	860	495	705
	100	535	900	495	705	465	1040	495	628	500	900	495	705
	112	545	960	495	705	475	1080	495	628	510	960	495	705
400	90	585	930	525	786	500	950	525	701	540	930	525	786
	100	595	980	525	786	510	1000	525	701	550	980	525	786
	112	605	1030	525	786	520	1160	525	701	560	1030	525	786
	132	615	1050	525	786	530	1180	525	701	570	1050	525	786
450	90	650	1000	580	877	548	1120	580	776	590	1000	580	877
	100	660	1050	580	877	558	1170	580	776	600	1050	580	877
	112	670	1100	580	877	568	1220	580	776	610	1100	580	877
	132	680	1120	580	877	578	1270	580	776	620	1120	580	877
500	90	720	1100	620	968	610	1250	620	850	650	1100	620	968
	100	730	1130	620	968	620	1280	620	850	660	1130	620	968
	112	740	1180	620	968	630	1330	620	850	670	1180	620	968
	132	750	1200	620	968	640	1350	620	850	680	1200	620	968
560	100	805	1210	665	1093	680	1370	665	956	720	1210	665	1093
	112	815	1260	665	1093	690	1420	665	956	730	1260	665	1093
	132	825	1280	665	1093	700	1460	665	956	740	1280	665	1093
	160	835	1360	665	1093	710	1540	665	956	750	1360	665	1093
180	845	1400	665	1093	720	1580	665	956	760	1400	665	1093	

SYQS-E

		0°				90°				180°			
左旋 LG Left Hand													
右旋 RD Right Hand													
型号	电机	L	A	B	C	L	A	B	C	L	A	B	C
630	100	895	1310	715	1220	755	1530	715	1062	795	1310	715	1220
	112	905	1360	715	1220	765	1580	715	1062	805	1360	715	1220
	132	915	1380	715	1220	775	1600	715	1062	815	1380	715	1220
	160	930	1450	715	1220	790	1680	715	1062	830	1450	715	1220
	180	940	1500	715	1220	800	1730	715	1062	840	1500	715	1220
710	100	1005	1430	770	1366	840	1670	770	1184	885	1430	770	1366
	112	1015	1480	770	1366	850	1720	770	1184	895	1480	770	1366
	132	1025	1500	770	1366	860	1740	770	1184	905	1500	770	1366
	160	1040	1570	770	1366	875	1800	770	1184	920	1570	770	1366
	180	1050	1620	770	1366	885	1850	770	1184	930	1620	770	1366
800	112	1130	1580	825	1548	950	1880	825	1330	990	1580	825	1548
	132	1140	1600	825	1548	960	1900	825	1330	1000	1600	825	1548
	160	1155	1650	825	1548	975	1950	825	1330	1015	1650	825	1548
	180	1165	1720	825	1548	985	2020	825	1330	1025	1720	825	1548
	200	1175	1770	825	1548	995	2070	825	1330	1035	1770	825	1548
900	112	1270	1730	905	1728	1060	2060	905	1488	1110	1730	905	1728
	132	1280	1750	905	1728	1070	2080	905	1488	1110	1750	905	1728
	160	1295	1800	905	1728	1085	2130	905	1488	1125	1800	905	1728
	180	1310	1880	905	1728	1095	2220	905	1488	1135	1880	905	1728
	200	1320	1920	905	1728	1105	2250	905	1488	1145	1920	905	1728
1000	132	1400	1900	975	1890	1175	2250	975	1621	1215	1900	975	1890
	160	1415	1950	975	1890	1190	2300	975	1621	1230	1950	975	1890
	180	1425	2030	975	1890	1200	2380	975	1621	1240	2030	975	1890
	200	1435	2070	975	1890	1210	2420	975	1621	1250	2070	975	1890
	225	1445	2130	975	1890	1220	2480	975	1621	1260	2130	975	1890
250	1455	2200	975	1890	1230	2550	975	1621	1270	2200	975	1890	
280	1465	2250	975	1890	1240	2600	975	1621	1280	2250	975	1890	

SYQS-E

		0°				90°				180°			
左旋 LG Left Hand													
右旋 RD Right Hand													
型号	电机	L	A	B	C	L	A	B	C	L	A	B	C
280	80	425	760	430	568	375	850	430	516	410	760	430	568
	90	435	780	430	568	385	860	430	516	420	780	430	568
	100	445	800	430	568	395	880	430	516	430	800	430	568
	112	455	850	430	568	405	930	430	516	440	850	430	568
	132	465	870	430	568	415	950	430	516	450	870	430	568
315	80	465	800	465	628	405	900	465	568	440	800	465	628
	90	475	820	465	627	415	920	465	568	450	820	465	627
	100	485	850	465	628	425	950	465	568	460	850	465	628
	112	495	900	465	628	435	1000	465	568	470	900	465	628
355	80	515	850	495	705	445	1000	495	628	480	850	495	705
	90	525	860	495	705	455	1000	495	628	490	860	495	705
	100	535	900	495	705	465	1040	495	628	500	900	495	705
	112	545	960	495	705	475	1080	495	628	510	960	495	705
400	90	585	930	525	786	500	950	525	701	540	930	525	786
	100	595	980	525	786	510	1000	525	701	550	980	525	786
	112	605	1030	525	786	520	1160	525	701	560	1030	525	786
	132	615	1050	525	786	530	1180	525	701	570	1050	525	786
	160	615	1100	525	786	530	1230	525	701	570	1100	525	786
450	90	650	1000	580	877	548	1120	580	776	590	1000	580	877
	100	660	1050	580	877	558	1170	580	776	600	1050	580	877
	112	670	1100	580	877	568	1220	580	776	610	1100	580	877
	132	680	1120	580	877	578	1270	580	776	620	1120	580	877
500	90	720	1100	620	968	610	1250	620	850	650	1100	620	968
	100	730	1130	620	968	620	1280	620	850	660	1130	620	968
	112	740	1180	620	968	630	1330	620	850	670	1180	620	968
	132	750	1200	620	968	640	1350	620	850	680	1200	620	968
560	100	805	1210	665	1093	680	1370	665	956	720	1210	665	1093
	112	815	1260	665	1093	690	1420	665	956	730	1260	665	1093
	132	825	1280	665	1093	700	1460	665	956	740	1280	665	1093
	160	835	1360	665	1093	710	1540	665	956	750	1360	665	1093
	180	845	1400	665	1093	720	1580	665	956	760	1400	665	1093

SYQS-E

		0°				90°				180°			
左旋 LG Left Hand													
右旋 RD Right Hand													
型号	电机	L	A	B	C	L	A	B	C	L	A	B	C
630	100	895	1310	715	1220	755	1530	715	1062	795	1310	715	1220
	112	905	1360	715	1220	765	1580	715	1062	805	1360	715	1220
	132	915	1380	715	1220	775	1600	715	1062	815	1380	715	1220
	160	930	1450	715	1220	790	1680	715	1062	830	1450	715	1220
	180	940	1500	715	1220	800	1730	715	1062	840	1500	715	1220
	200	950	1550	715	1220	810	1780	715	1062	850	1550	715	1220
710	100	1005	1430	770	1366	840	1670	770	1184	885	1430	770	1366
	112	1015	1480	770	1366	850	1720	770	1184	895	1480	770	1366
	132	1025	1500	770	1366	860	1740	770	1184	905	1500	770	1366
	160	1040	1570	770	1366	875	1800	770	1184	920	1570	770	1366
	180	1050	1620	770	1366	885	1850	770	1184	930	1620	770	1366
800	100	1060	1670	770	1366	895	1900	770	1184	940	1670	770	1366
	112	1070	1700	770	1366	905	1930	770	1184	950	1700	770	1366
	132	1130	1580	825	1548	950	1880	825	1330	990	1580	825	1548
	160	1140	1600	825	1548	960	1900	825	1330	1000	1600	825	1548
	180	1155	1650	825	1548	975	1950	825	1330	1015	1650	825	1548
	200	1165	1720	825	1548	985	2020	825	1330	1025	1720	825	1548
900	100	1175	1770	825	1548	995	2070	825	1330	1035	1770	825	1548
	112	1185	1820	825	1548	1005	2120	825	1330	1045	1820	825	1548
	132	1195	1880	825	1548	1015	2180	825	1330	1055	1880	825	1548
	160	1270	1730	905	1728	1060	2060	905	1488	1110	1730	905	1728
	180	1280	1750	905	1728	1070	2080	905	1488	1110	1750	905	1728
	200	1295	1800	905	1728	1085	2130	905	1488	1125	1800	905	1728
1000	100	1310	1880	905	1728	1095	2220	905	1488	1135	1880	905	1728
	112	1320	1920	905	1728	1105	2250	905	1488	1145	1920	905	1728
	132	1330	1980	905	1728	1115	2320	905	1488	1155	1980	905	1728
	160	1340	2050	905	1728	1125	2380	905	1488	1165	2050	905	1728
	180	1400	1900	975	1890	1175	2250	975	1621	1215	1900	975	1890
	200	1415	1950	975	1890	1190	2300	975	1621	1230	1950	975	1890
1000	100	1425	2030	975	1890	1200	2380	975	1621	1240	2030	975	1890
	112	1435	2070	975	1890	1210	2420	975	1621	1250	2070	975	1890
	132	1445	2130	975	1890	1220	2480	975	1621	1260	2130	975	1890
	160	1455	2200	975	1890	1230	2550	975	1621	1270	2200	975	1890
	180	1465	2250	975	1890	1240	2600	975	1621	1280	2250	975	1890

SYQS-R

		0°				90°				180°			
左旋 LG Left Hand													
右旋 RD Right Hand													
型号	电机	L	A	B	C	L	A	B	C	L	A	B	C
280	71	415	740	400	568	365	830	400	516	400	740	400	568
	80	425	760	400	568	375	850	400	516	410	760	400	568
	90	435	780	400	568	385	860	400	516	420	780	400	568
	100	445	800	400	568	395	880	400	516	430	800	400	568
	112	455	850	400	568	405	930	400	516	440	850	400	568
315	71	455	780	435	628	395	880	435	568	430	780	435	628
	80	465	800	435	628	405	900	435	568	440	800	435	628
	90	475	820	435	628	415	920	435	568	450	820	435	628
	100	485	850	435	628	425	950	435	568	460	850	435	628
	112	495	900	435	628	435	1000	435	568	470	900	435	628
355	71	505	830	465	705	435	960	465	628	470	830	465	705
	80	515	850	465	705	445	980	465	628	480	850	465	705
	90	525	860	465	705	455	1000	465	628	490	860	465	705
	100	535	900	465	705	465	1040	465	628	500	900	465	705
	112	545	960	465	705	475	1080	465	628	510	960	465	705
400	71	565	880	495	786	480	900	495	701	520	880	495	786
	80	575	900	495	786	490	920	495	701	530	900	495	786
	90	585	930	495	786	500	950	495	701	540	930	495	786
	100	595	980	495	786	510	1000	495	701	550	980	495	786
	112	605	1030	495	786	520	1160	495	701	560	1030	495	786
450	132	615	1050	495	786	530	1180	495	701	570	1050	495	786
	80	640	980	550	877	548	1100	550	776	580	980	550	877
	90	650	1000	550	877	548	1120	550	776	590	1000	550	877
	100	660	1050	550	877	558	1170	550	776	600	1050	550	877
	112	670	1100	550	877	568	1220	550	776	610	1100	550	877
500	132	680	1120	550	877	578	1270	550	776	620	1120	550	877
	80	710	1080	590	968	600	1230	590	850	640	1080	590	968
	90	720	1100	590	968	610	1250	590	850	650	1100	590	968
	100	730	1130	590	968	620	1280	590	850	660	1130	590	968
	112	740	1180	590	968	630	1330	590	850	670	1180	590	968
560	132	750	1200	590	968	640	1350	590	850	680	1200	590	968
	90	795	1160	635	1093	670	1320	635	956	710	1160	635	1093
	100	805	1210	635	1093	680	1370	635	956	720	1210	635	1093
	112	815	1260	635	1093	690	1420	635	956	730	1260	635	1093
	132	825	1280	635	1093	700	1460	635	956	740	1280	635	1093
160	835	1360	635	1093	710	1540	635	956	750	1360	635	1093	

SYQS-R

		0°				90°				180°			
左旋 LG Left Hand													
右旋 RD Right Hand													
型号	电机	L	A	B	C	L	A	B	C	L	A	B	C
630	90	885	1260	685	1220	745	1480	685	1062	785	1260	685	1220
	100	895	1310	685	1220	755	1530	685	1062	795	1310	685	1220
	112	905	1360	685	1220	765	1580	685	1062	805	1360	685	1220
	132	915	1380	685	1220	775	1600	685	1062	815	1380	685	1220
	160	930	1450	685	1220	790	1680	685	1062	830	1450	685	1220
710	90	995	1380	740	1366	830	1620	740	1184	875	1380	740	1366
	100	1005	1430	740	1366	840	1670	740	1184	885	1430	740	1366
	112	1015	1480	740	1366	850	1720	740	1184	895	1480	740	1366
	132	1025	1500	740	1366	860	1740	740	1184	905	1500	740	1366
	160	1040	1570	740	1366	875	1800	740	1184	920	1570	740	1366

注: L=风机轮与电机轮之间的中心距

L=Center distance between fan and motor pulley

SYQS系列风机运行极限

SYQS Series Fan Operational Limits

			280	315	355	400	450	500	560	630	710	800	900	1000	1120	1250	1400
极限吸收功率 Max. Absorbed power	R	KW	2	2	2.5	3	4	6	8	8	9	\	\	\	\	\	\
	E	KW	4	4	6	7	7	15	18	20	22	25	30	45	80	100	100
	C	KW	4	4	6	7	7	15	18	20	22	25	30	45	80	100	100
极限转速 Max. Speed	R	rpm	4000	3200	2800	2400	2200	2400	2600	1600	1400	\	\	\	\	\	\
	E	rpm	4500	4000	3800	3200	2800	2800	2000	2200	2000	1600	1400	1400	1300	1200	1000
	C	rpm	4500	4000	3800	3200	2800	2800	2000	2000	2000	1600	1400	1400	1300	1200	1000
极限温度 (最低-20℃) Air Temperature Limits (Min-20℃)	R	Max℃	85	85	85	85	85	85	85	85	85	\	\	\	\	\	\
	E	Max℃	85	85	85	85	85	85	85	85	85	85	85	85	85	85	85
	C	Max℃	180	180	180	180	180	180	180	180	180	180	180	180	180	180	180
风机质量 Fan Weight	R	Kg	17	27	39	44	55	70	110	125	175	\	\	\	\	\	\
	E	Kg	29	39	52	58	73	91	140	160	210	245	350	435	600	790	1080
	C	Kg	27	37	50	55	72	89	138	161	215	252	360	445	610	800	1100

本样本中所述的风机特性,如尺寸、性能参数等,本公司保留更改的权利,恕不另行通知;如有不明之处,请来电询问。  
This fan features described in the sample, such as size, performance parameters, the Company reserves the right to change without notice; if unknown place, please call us.



## SYDS 系列离心式空调风机

## Centrifugal Ventilators

浙江亿利达风机股份有限公司特此证明，此处所示 SYDS 系列离心风机获得了加盖 AMCA 印章的授权。所示额定值系根据 AMCA 出版物 211 和 AMCA 出版物 311 所进行测试和程序确定，并符合 AMCA 认证额定值计划的要求。

这里描述的所有离心风机都已经取得了 AMCA 印章，他们的认证数据见第 209 页到 220 页。

Zhejiang Yilida Ventilator Co.,Ltd. certifies that the SYDS Series fans shown herein are licensed to bear the AMCA Seal. The ratings shown are based on tests and procedures performed in accordance with AMCA Publication 211 and AMCA Publication 311 and comply with the requirements of the AMCA Certified Ratings Program.

All the Centrifugal Fans described herein are licensed to bear the AMCA Seal, and their certified ratings are shown on pages 209 through 220.



概述

SYDS系列前向多翼单进风离心风机采用国际同类产品先进技术自行开发,通过了AMCA国际认证并取得AMCA印章。该样本中列出的12种规格风机,流量范围从700m<sup>3</sup>/h-50000m<sup>3</sup>/h,全压从200Pa-1500Pa,产品具有效率高、噪声低、耗能少、通用性强、安全性好等特点。广泛应用于各类中央空调机组及其暖通空调、净化、通风等空调系统。

Summary

The SYDS Series of centrifugal air conditioning fans was developed with advanced technologies. They are licensed to bear the AMCA Seal for air performance, sound, and FEG. The SYDS Series includes 12 models as described in this catalogue. The volume flow of the SYDS Series ranges from 700 m<sup>3</sup>/h to 50,000 m<sup>3</sup>/h, the total pressure ranges from 200Pa to 1,500Pa. Some of the features and characteristics of these fans are: forward impeller blades, a wide range of applications, high efficiency, low noise, and low power consumption. These fans are ideal for use in central air-conditioning systems, in purifiers. They are also suitable for use in a variety of other ventilation applications.

命名方式

SYDS 400 L

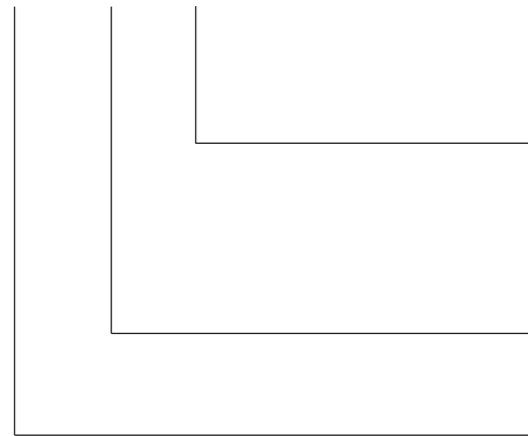

Nomenclature

- 结构型式 Construction type
- R 型 (基本型) Type R (Basic Model)
- E 型 (加强型) Type E (Heavy Duty Model)
- C 型 (悬臂型) Type C (Handing Model)
- 叶轮名义直径 (mm) Nominal diameter of impeller (mm)
- 前向多翼离心风机系列代号 Fan series with multi-vane forward curved blades

产品型式

1. 旋向

SYDS 系列风机可分为左旋(LG)和右旋(RD)两种旋转方式,从风机皮带轮一端正视,叶轮顺时针旋转的称为右旋风机,逆时针旋转的称为左旋风机。

1. Rotation

SYDS series fans have two direction of rotations, left-hand rotation (LG) and right-hand rotation (RD); Viewing from drive side, if the impeller rotates clockwise, it is left hand (LG) rotation. If the impeller rotates counter clockwise, it is right-hand (RD).

2. 出风口方向

SYDS 系列出风口可按图 1 所示制成 0°、90°、180°、270° 四种出风方向。

2. Discharge Direction

As shown in Fig1, SYDS Series fans can be constructed in four discharge directions: 0°, 90°, 180°, and 270°.

图1 (Fig 1)

	0°	90°	180°	270°
左旋 LG Left Hand				
右旋 RD Right Hand				

3. 结构形式

SYDS 系列风机可按图 2 所示制成 R 型、E 型、C 型。

3. Type of Construction

As shown in Fig 2, SYDS series fans can be divided into category R, E, C.

图2 (Fig 2)

风机类型 Fan Type	机号 Fan Size	风机示意图 Fan Diagram	轴承实物图 Bearing Type
R 型 TYPE R	280-710		
E 型 TYPE E	280-1000		
C 型 TYPE C	280-1000		

## 产品结构

SYDS 系列风机主要由机壳、叶轮、框架、轴承及轴构成。出口法兰(为可选件)。

### 1. 机壳

机壳采用热镀锌钢板制造,侧板具有符合空气动力学的外形,进风口整体拉伸成型,蜗板采用点焊或“Pittsburg seam locking”的连接方式与侧板连成一体。

### 2. 叶轮

前向多翼叶轮采用优质热镀锌钢板制成,叶片设计成符合空气动力学的特定形状,使得效率最高,噪声最低。叶片用铆爪固定在中盘及端圈上,在最大功率连续运转时,叶轮将具备足够的刚度。所有叶轮进行静平衡和动平衡测试,内控精度达到 G2.5 级(ANSI/AMCA 204-05)。

### 3. 框架

R 型风机框架采用热镀锌钢板剪切、折弯制成,TOX 连接保证了所需的尺寸精度和应有的刚度;E 型、C 型风机框架由角钢和扁钢冷弯焊接制成表面喷塑处理,以保证足够的刚度和强度。

### 4. 轴承

SYDS 系列风机均采用优质滚珠轴承,并根据噪声最低来选择,该轴承设有加润滑油的孔,已预先加润滑油并自动对中;R 型风机的轴承安装在轴承支架上,并设有防振垫圈;E 型、C 型风机则采用带座向心球轴承;轴承寿命为 L10≥100000 小时。

### 5. 轴

风机轴采用 40Cr 低合金钢,经车、调质热处理、磨削制成,强度高,挠度小,严格控制轴径尺寸公差及形位公差,每根轴均经过涂覆防锈处理。轴尺寸设计应满足第一临界转速至少为风机最大运行转速的 1.4 倍。

### 6. 出风口法兰

进风口法兰采用优质冷轧板制成,整体喷塑。出风口法兰采用热镀锌钢板制成,出风口法兰与蜗壳的连接采用 TOX 免焊工艺,外观精美,并具有足够的刚度与强度。

## Construction of Product

SYDS series fans are mainly constructed of housing, impeller, frame, bearing and shaft. Outlet flange (is optional).

### 1. Housing

The housing is made of hot galvanized steel sheet. The side plates include inlets cones that are designed with the best aerodynamics for inlet condition. The scroll is fixed to the side plates by spot welding or "Pittsburg seam locking".

### 2. Impeller

Forward curved impeller is constructed of high-grade hot galvanized steel sheet with the advanced aerodynamics profile to achieve the highest efficiency and the lowest noise level. The impeller is fixed on the center plate and on the end ring with riveting grip pres. The impeller is constructed with maximum strength that endures the continuous operation with maximum power. All impellers are balanced to ANSI/AMCA Standard 204-05. Yilida's internal standard is G2.5 or higher for wheel balancing.

### 3. Frame

The frames for type R construction are made of galvanized steel angle iron bars. The cutting and bending of the frame parts, as well as the TOX connections, are formed with the use of toolings to ensure the high accuracy and the rigidity of the frames; The frames for E and C constructions are welded by angle steel and flat steel, and finished with polyester coating in order to ensure sufficient rigidity and strength.

### 4. Bearings

Ball bearings are used in all of the SYDS Series fans. These are high-quality bearings and selected to minimize the fan noise levels. The bearings are pre-lubricated, sealed, and self-centering. For type R constructions, the bearings are supplied with lubrication fittings. For type E and C constructions, the bearings are supplied with radial bearing. All Yilida bearing service life (L10) are over 100,000 hours (L10≥100000 hours).

### 5. Shaft

The shafts are made of 40 Cr carbon steel bars. The shafts are rough machined and then stress relieved with heat treatment before final machining. The shaft diameters are machined to very accurate tolerance levels and they are fully checked to ensure precision fit. Each shaft is made turned, ground and polished. They are coated after assembly to provide corrosion resistance. Shaft size should be designed to meet the first critical speed of at least fan maximum running speed 1.4 times.

### 6. Outlet Flange

The inlet flange is made of high-grade cold-rolling sheet with polyester coating. The outlet flange is made of galvanized steel. The connections of the flange components to the scroll are made using a TOX non-welding process. This maintains a good flange appearance while also providing sufficient strength and rigidity.

## 风机性能

### 1、风机选型示意图例

型号 Type	SYDS560R
风量 Volume	$q_v=10000\text{m}^3/\text{h}$
全压 Total Pressure	$P_{TF}=800\text{Pa}$
动压 Dynamic Pressure	$P_{df}=67\text{Pa}$
出口速度 Outlet Velocity	$C=10.56\text{m/s}$
风机转速 Fan Speed	$n=768\text{r/min}$
轴功率 Shaft Power	$P_{in}=3.43\text{KW}$
A 声功率级 A Sound Power Level	$L_{wA}=87\text{dB(A)}$
全压效率 Total Efficiency	$\eta_{IF}=64.8\%$

## Performance Chart

### 1. Fan Performance Curve

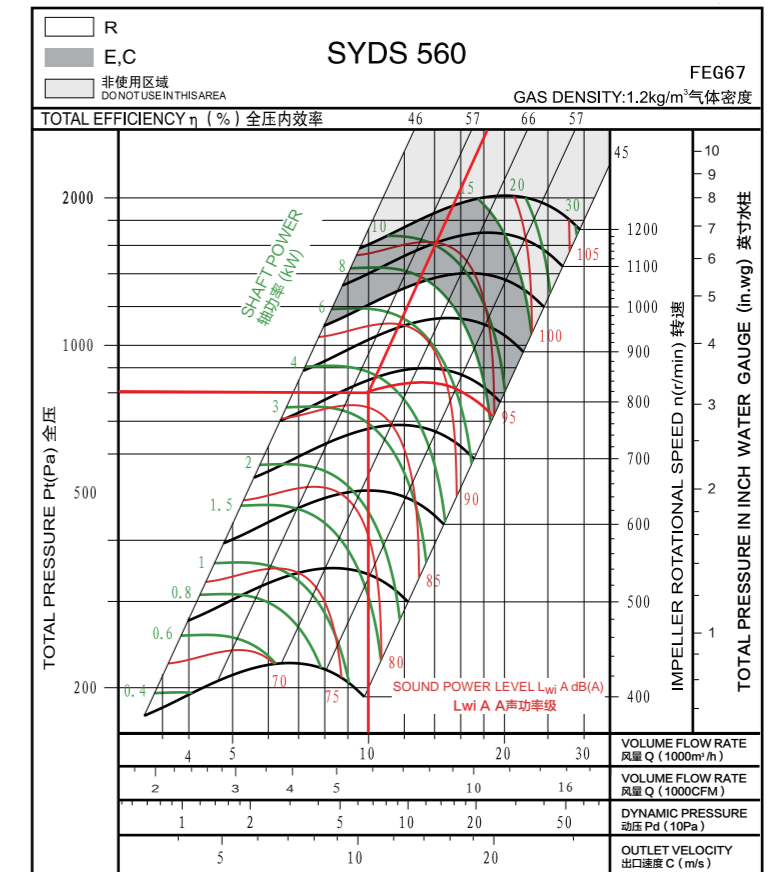



## 2、电机的选配

性能曲线图上的功率 Psh 是指风机的轴功率。  
配套电机的功率： $P_{sh,p} = P_{sh} \times K \div \eta_{me}$   
风机传动效率的取值方法可参照表 1，  
电机容量安全系数的取值方法可参照表 2。

表1 (Table 1)

风机传动方式	Drive Type	$\eta_{me}$
电机直联传动	Motor Direct Drive	1
联轴器直联传动	Coupling Direct Drive	0.98
三角皮带传动	V-Belt Drive	0.95

## 2. Motor Selection

The power (Psh) on the performance chart refers to the shaft power of the fan.  
The rated power of the drive motor equals the total required shaft input multiplied by the safety factor :  $P_{sh,p} = P_{sh} \times K \div \eta_{me}$   
The value of mechanical drive efficiency can be obtained from Table 1.  
The required safety factors is provided in Table 2.

表2 (Table 2)

电机功率 Power of electric motor (Kw)	K值 Value k
$\leq 0.75Kw$	1.3
$\leq 2.2Kw$	1.2
$\leq 7.5Kw$	1.15
$\geq 11Kw$	1.1

## 安装与维护

### A) 皮带传动安装

1. 拆除风机轴端的保护并检查有无缺口和毛刺；
2. 检查风机和电机轴之间的平行度；
3. 中心距控制在  $0.7(d1+d2) < a < 2(d1+d2)$ ，前向风机皮带速度应控制在 10~15m/s；后向风机皮带速度应控制在 25~35m/s；
4. 将皮带轮套在轴上滑进去，不要敲击，以免损伤轴承；
5. 用一根直尺把风机和电机上的带轮对齐并紧固；
6. 把皮带套进皮带轮，不要撬、挤压，以免损伤皮带；
7. 调整张紧度直至皮带看起来松紧适度，风机运行几分钟后，再调整皮带至合适的张紧度；
8. 关掉风机，移动电机座以调整张紧度，当风机工作时，皮带紧的一边是两个皮带轮连成的一条直线，松的一边有轻微弧形。

### A) V-belt Drive Installation

1. Remove the protective coating from the ends of the fan shaft and ensure that the shaft ends are free of nick and burrs.
2. Check fan and motor shafts for alignment.
3. The center distance must be controlled as  $0.7(d1+d2) < a < 2(d1+d2)$ , The belt speed of forward curve fan should be more than 10m/s, but less than 15m/s, ( $10 < v < 15m/s$ ). The belt speed of backward curve fan should be more 25m/s, but less than 35m/s ( $25 < v < 35m/s$ ).
4. Slide sheaves on to the shafts, Do not hammer the sheaves on to the shafts with force as this may result in bearing damage.
5. Align fan and motor sheaves with a straight-edge, and tighten the sheaves.
6. Place belts over the sheaves with care. Do not bend or squeeze the belts or it might get damaged.
7. Adjust the belt tension until the belts appear snug. Run the unit for a few minutes and allow the belts to set properly.
8. Switch off the fan, adjust the belt tension by moving the motor base. When in operation, the tight side of the belts should be in a straight line from sheave to sheave and there should be a slight bow on the slack side.

图3 (Fig3)

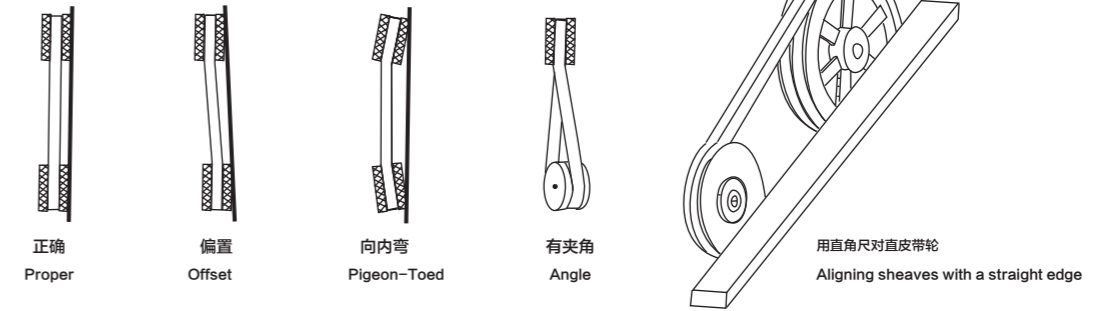

### B) 皮带松紧度

合适的皮带松紧度对使用寿命来说很重要，太紧会给皮带和轴承带来额外的负载，降低它们的使用寿命，太松会出现皮带打滑现象而产生热并降低使用寿命。  
皮带松紧度量具用来判断皮带是否松紧合适。量具本身带有一个尺表，根据皮带轮中心距和皮带横截面确定皮带张紧力的大小，如图 4 和表 3。  
如没有皮带张紧度量具，应调节皮带松紧至风机启动时皮带不发生尖叫声为止，如发生短促的叫声是允许的。  
拉紧皮带后、开动风机之前，重新检查皮带轮的对齐情况，如右必要则重新调整对齐。新皮带在开始使用时可能有点拉伸，则应在运行几天后重新检查皮带张紧度。

### B) Belt Tension

A proper level of belt tension is required in order to obtain a satisfactory belt life. If the belt tension level is too high, excessive loads will be imposed on the belts and the bearing, and this will reduce the lives of both of these components. If the belt tension level is too low, the belt will slip. Belt slippage generates a large amount of heat, and this heat will drastically reduce the life of a belt.  
Belt-tensioning gauges can be used to determine whether the belts are tensioned properly. A chart is normally supplied with the gauge which indicates the ranges of forces required to deflect the belts by a given amount to obtain the proper belt tension level. The required forces are based upon the center distance of the sheaves and the belt cross-section. The belts are properly tensioned when the forces required to deflect the belt are within the specified range, see Fig 4 and Table 3.  
If a belt-tensioning gauge is not available, then the belt should be tightened just enough so that the belt does not squeal when the ventilator is started. A very short period of noise during the starting of a ventilator is allowable, but a squeal lasting several seconds or longer is not acceptable. After tensioning the belts and before starting the fan, check to make sure that the sheaves are properly aligned. Realign the sheaves if necessary. Note that new belts may stretch a little during initial use, so the belt tension level should be checked after a few days of operation.

表4 (Fig4)

与中心距有关的皮带张紧度指示  
Belt tension indicator applied to mid centre distance.



表3 (Table3)

皮带截面 Belt Section	使皮带向下移动16mm径向距离1米所需的力 Force required to deflect belt 16mm per metre of span		
	张紧力 (小皮带轮直径) Small Pulley/Diameter (mm)	牛顿 Newtonian (N)	千克力 Kilogram force (Kgf)
SPZ	56-95	13-20	1.3-2.0
	100-140	20-25	2.0-2.5
SPA	80-132	25-35	2.5-3.6
	140-200	35-45	3.6-4.6
SPB	112-224	45-65	4.6-6.6
	236-315	65-85	6.6-8.7
SPC	224-335	85-115	8.7-11.7
	375-560	115-150	11.7-15.3
A	80-140	10-15	1.1-1.5
B	125-200	20-30	2.0-3.1

### C) 轴承润滑

风机使用带座轴承，可通过加油嘴注入润滑油。润滑油有效期取决于油脂类型、轴承的转速和工作温度。判断是否加油的最好办法是当加新油时观察清除下来的旧油脂，可延长换油脂的间隔，如果清除下来的油脂比新的黑得多表明油脂已氧化，应缩短换油脂的间隔。

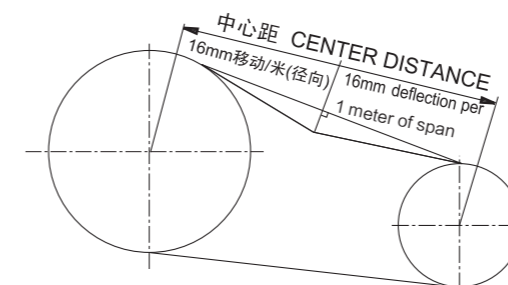
### C) Bearing Lubrication

The fan bearings are filled with lubricant when they ship from the factory, so the bearings do not require any additional grease to be supplied before starting the fan. The fans that are equipped with pillow block bearing are provided with lubrication fittings, and these fittings allow for additional lubrication to the supplied to the bearings at regular intervals. The allowable period of time between lubrication of these bearings depends upon the operating speeds and temperatures of the bearing as well as on the type of lubrication. It is recommended to inspect the condition of the grease that is discharged from the bearings when new grease is added. If the discharged grease looks similar to the new grease, then a longer period of time between lubrications is possible. If the discharged grease is much darker than the new grease, this indicates that the grease is being oxidized and more frequent lubrications of the bearings are required.

### 说明

- 1). 订货时须注明风机型号、转速、风量、风压、出风口方向和旋转方向。若需配套皮带、皮带轮、电机、安装底座等配件及其它特殊要求可在订货时提出。
- 2). 在安装前应对风机各部件进行检查，对叶轮、主轴和轴承等主要机件应重点细致检查，如有损伤应修复后再安装使用。
- 3). 检查机壳和其它壳体内部，不应有掉入、遗留的工具和杂物。
- 4). 风机正式运转前，需检查电机的转向是否符合风机转向的要求。
- 5). 风管与出风口之间应采用软连接，接头不得拉紧。
- 6). 风机安装后用手或杠杆拨动叶轮，检查是否过紧或碰撞现象，确认无这些现象时方可进行试转。
- 7). 风机配用电机功率是指在特定工况下，风机轴功率加上机械损失与电机容量安全系数而言，并非出风口全敞开时所需的功率。为防止电机超功率运行而烧毁，严禁风机出风口或进风口不接管路或未加外界任何阻力进行空运转。
- 8). 风机在无较大腐蚀性气体、不含酸（碱）性和尘颗粒物小于150mg/m<sup>3</sup>的气体、温度小于85℃大于-20℃的气体环境下使用，风机在运输装卸过程中应小心轻放，防止碰撞挤压。

### Instructions

- 1) When placing the order, it is necessary to state the type of fan, speed, air volume, air pressure, discharge direction, rotation direction, type of electric motor and its specifications.
- 2) Prior to installation, the fan should be carefully inspected. Special care should be taken in checking the shaft, impeller and bearings. If there is an indication of any damage, the damaged parts should be repaired or replaced before the fan is installed or commissioned.
- 3) The inside of the scroll and casing need to be checked to make sure that there are no foreign objects inside the housing, such as tools or loose parts.
- 4) The rotational directions of the motor and impeller should be checked to ensure that they are in compliance with the specification and purchase orders.
- 5) A flexible connector should be used between the fan out let flange and its mating ductwork. The flex connector should not be over-stretched.
- 6) Following the installation, the impeller should be turned by hand or with the use of a wrench to make sure that it turns freely without colliding with other parts of the fan. Once all this is done, the fan can be commissioned normally.
- 7) The rated motor power as calculated herein might not be sufficient to drive the fan with an unrestricted discharge flow. Operating the fan with an unrestricted discharge outlet will result in flow rate that exceeds the specified fan capabilities. Such operation will quickly burn the motor and damage the fan. Great care must be taken in operating the fan to make sure that the maximum rated flows, as provided on the performance charts in this catalog, are not exceeded.
- 8) The fan is limited for use in areas where air substances are non-corrosive, non-toxics and non-erosive and where dust particles are less than 150mg/m<sup>3</sup> with a temperature between -20℃ and 85℃. Special care should be taken during transportation, load and unload.

### 技术参数

Wheel diameter	叶轮直径	D = 280 mm	Fan weight	风机质量	m = 30 kg
Moment of inertia	转动惯量	J = 0.032 kg·m <sup>2</sup>	Speed limit	极限转速	n <sub>max</sub> = 2400 r/min

### Technical Data

### 性能曲线

经认证的性能是B类安装：自由入口，管道出口。功率额定值(kW)不包括传输损失。各项性能额定值不包括附属物(附件)的影响。所示A加权声音性能额定值已按AMCA International标准301计算。所示值为安装类型B：自由入口，管道出口的声功率级（入口L<sub>wA</sub>）。

### Performance Curves

Performance certified is for installation type B: free inlet, ducted outlet. Power rating (kW) does not include transmission losses. Performance ratings do not include the effects of appurtenances (accessories). The A-weighted sound ratings shown have been calculated per AMCA International Standard 301. Values shown are for inlet L<sub>wA</sub> sound power levels for installation type B: free inlet, ducted outlet.

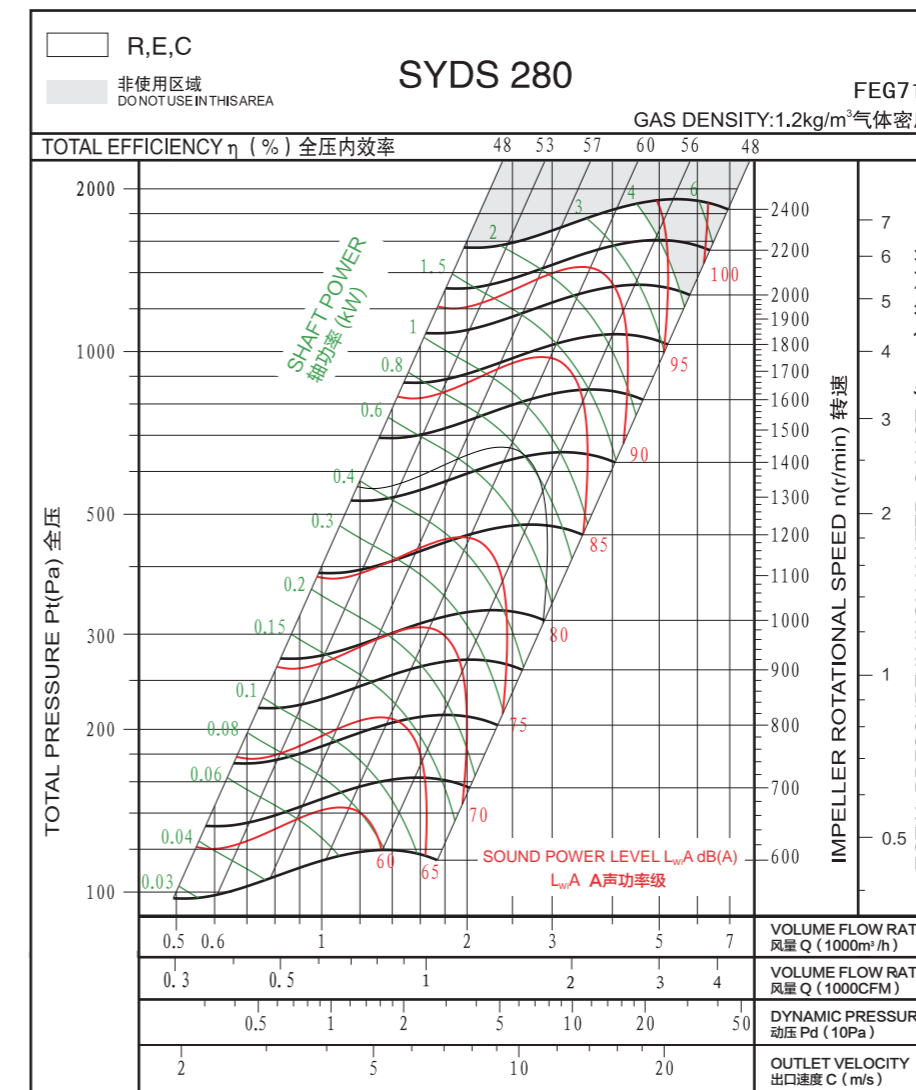

Measured in installation B according to AMCA Standard 210:

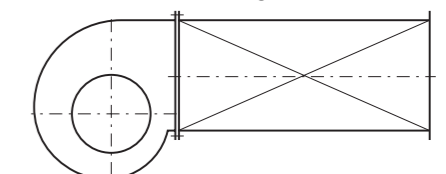

## 技术参数

## Technical Data

Wheel diameter 叶轮直径	D = 315 mm	Fan weight 风机质量	m = 33 kg
Moment of inertia 转动惯量	J = 0.055 kg·m <sup>2</sup>	Speed limit 极限转速	n <sub>max</sub> = 2000 r/min

## 技术参数

## Technical Data

Wheel diameter 叶轮直径	D = 355 mm	Fan weight 风机质量	m = 48 kg
Moment of inertia 转动惯量	J = 0.083 kg·m <sup>2</sup>	Speed limit 极限转速	n <sub>max</sub> = 2000 r/min

## 性能曲线

## Performance Curves

经认证的性能是B类安装：自由入口，管道出口。功率额定值(kW)不包括传输损失。各项性能额定值不包括附属物(附件)的影响。所示A加权声音性能额定值已按AMCA International标准301计算。所示值为安装类型B：自由入口，管道出口的声功率级（入口L<sub>wA</sub>）。

Performance certified is for installation type B: free inlet, ducted outlet. Power rating (kW) does not include transmission losses. Performance ratings do not include the effects of appurtenances (accessories). The A-weighted sound ratings shown have been calculated per AMCA International Standard 301. Values shown are for inlet L<sub>wA</sub> sound power levels for installation type B: free inlet, ducted outlet.

## 性能曲线

## Performance Curves

经认证的性能是B类安装：自由入口，管道出口。功率额定值(kW)不包括传输损失。各项性能额定值不包括附属物(附件)的影响。所示A加权声音性能额定值已按AMCA International标准301计算。所示值为安装类型B：自由入口，管道出口的声功率级（入口L<sub>wA</sub>）。

Performance certified is for installation type B: free inlet, ducted outlet. Power rating (kW) does not include transmission losses. Performance ratings do not include the effects of appurtenances (accessories). The A-weighted sound ratings shown have been calculated per AMCA International Standard 301. Values shown are for inlet L<sub>wA</sub> sound power levels for installation type B: free inlet, ducted outlet.

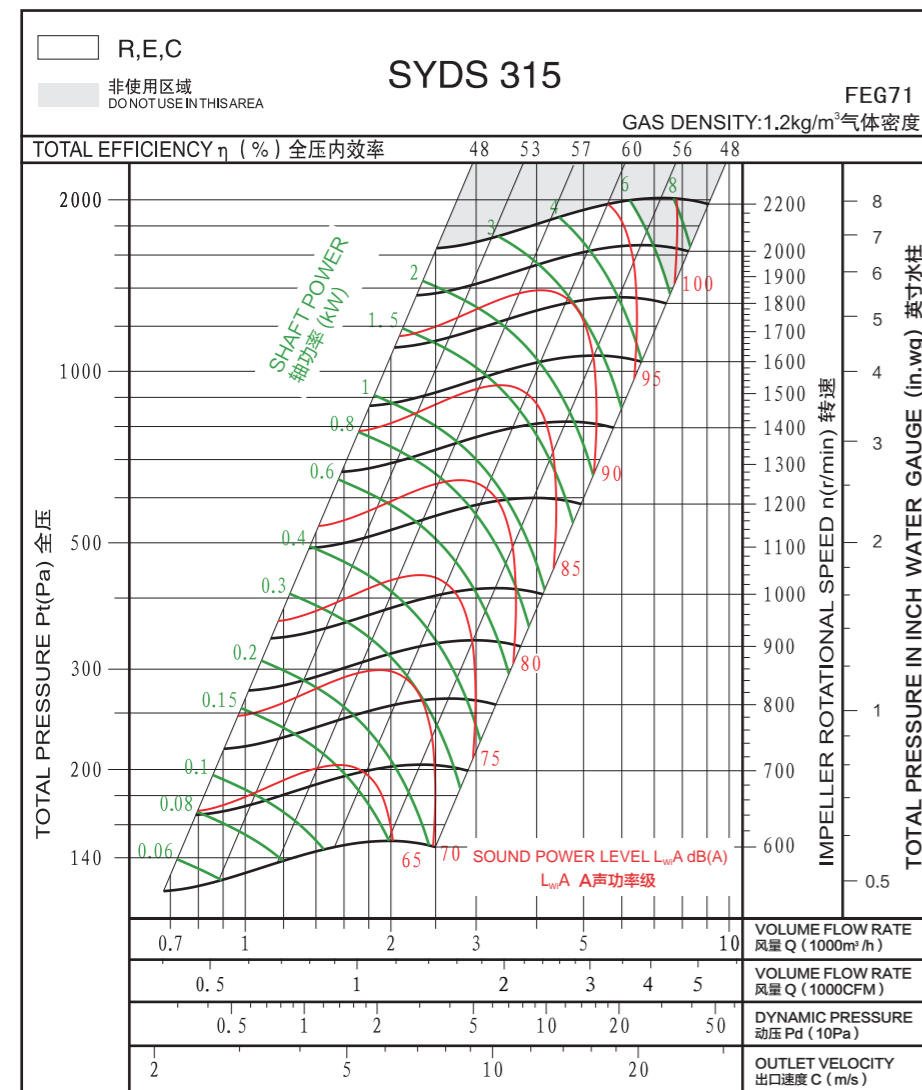

Measured in installation B according to AMCA Standard 210:

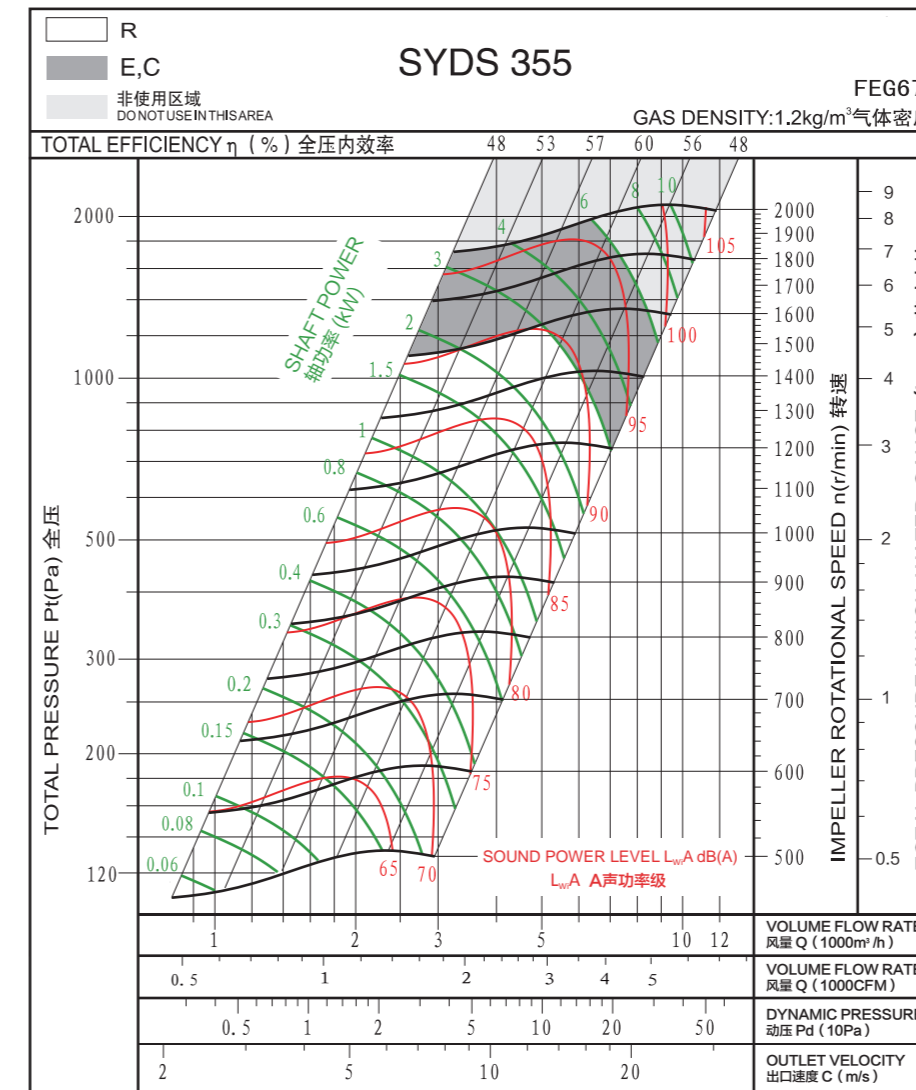
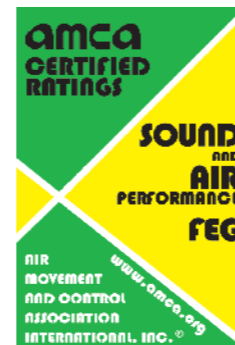
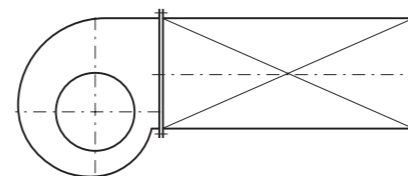

Measured in installation B according to AMCA Standard 210:

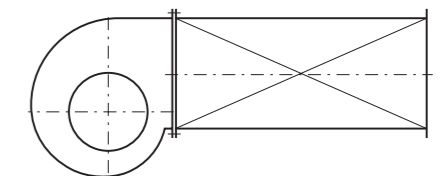



## 技术参数

## Technical Data

Wheel diameter 叶轮直径	D = 400 mm	Fan weight 风机质量	m = 57 kg
Moment of inertia 转动惯量	J = 0.17 kg·m <sup>2</sup>	Speed limit 极限转速	n <sub>max</sub> = 1800 r/min

## 技术参数

## Technical Data

Wheel diameter 叶轮直径	D = 450 mm	Fan weight 风机质量	m = 66 kg
Moment of inertia 转动惯量	J = 0.26 kg·m <sup>2</sup>	Speed limit 极限转速	n <sub>max</sub> = 1600 r/min

## 性能曲线

## Performance Curves

经认证的性能是B类安装：自由入口，管道出口。功率额定值(kW)不包括传输损失。各项性能额定值不包括附属物(附件)的影响。所示A加权声音性能额定值已按AMCA International标准301计算。所示值为安装类型B：自由入口，管道出口的声功率级（入口L<sub>wA</sub>）。

Performance certified is for installation type B: free inlet, ducted outlet. Power rating (kW) does not include transmission losses. Performance ratings do not include the effects of appurtenances (accessories). The A-weighted sound ratings shown have been calculated per AMCA International Standard 301. Values shown are for inlet L<sub>wA</sub> sound power levels for installation type B: free inlet, ducted outlet.

## 性能曲线

## Performance Curves

经认证的性能是B类安装：自由入口，管道出口。功率额定值(kW)不包括传输损失。各项性能额定值不包括附属物(附件)的影响。所示A加权声音性能额定值已按AMCA International标准301计算。所示值为安装类型B：自由入口，管道出口的声功率级（入口L<sub>wA</sub>）。

Performance certified is for installation type B: free inlet, ducted outlet. Power rating (kW) does not include transmission losses. Performance ratings do not include the effects of appurtenances (accessories). The A-weighted sound ratings shown have been calculated per AMCA International Standard 301. Values shown are for inlet L<sub>wA</sub> sound power levels for installation type B: free inlet, ducted outlet.

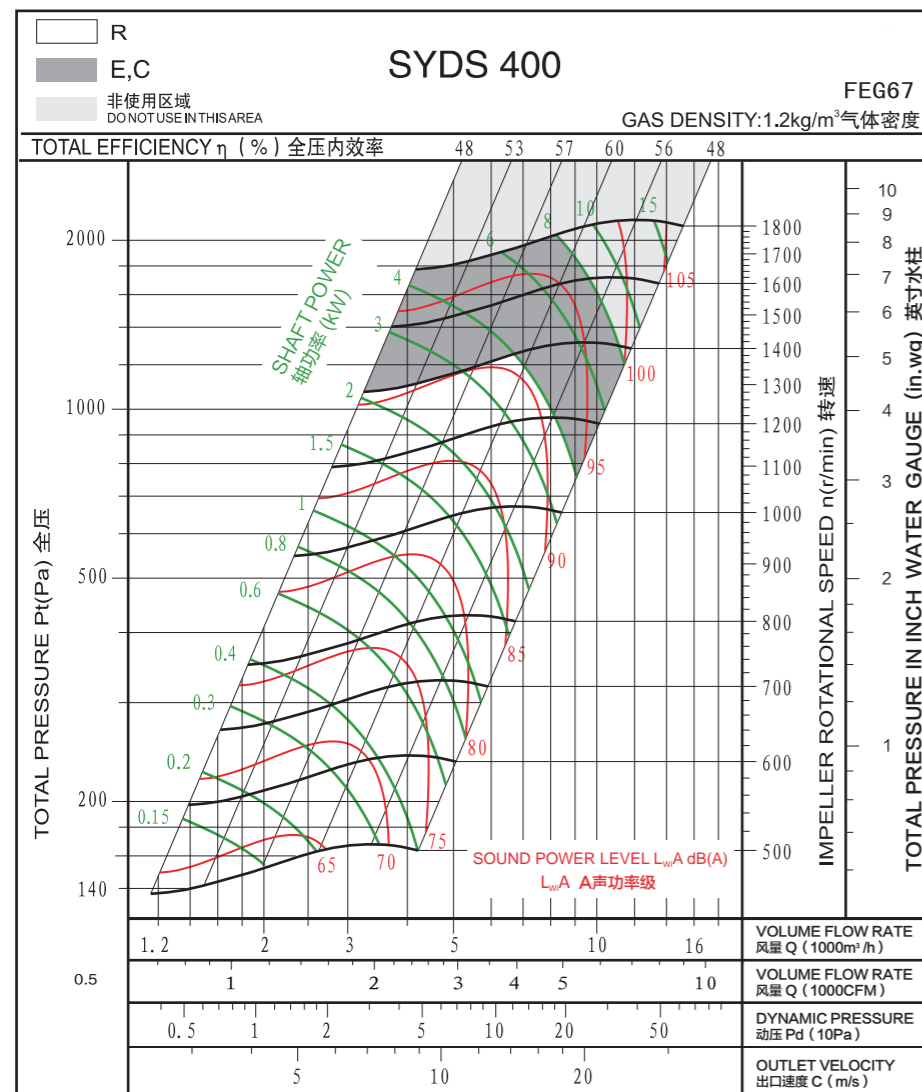

Measured in installation B according to AMCA Standard 210:

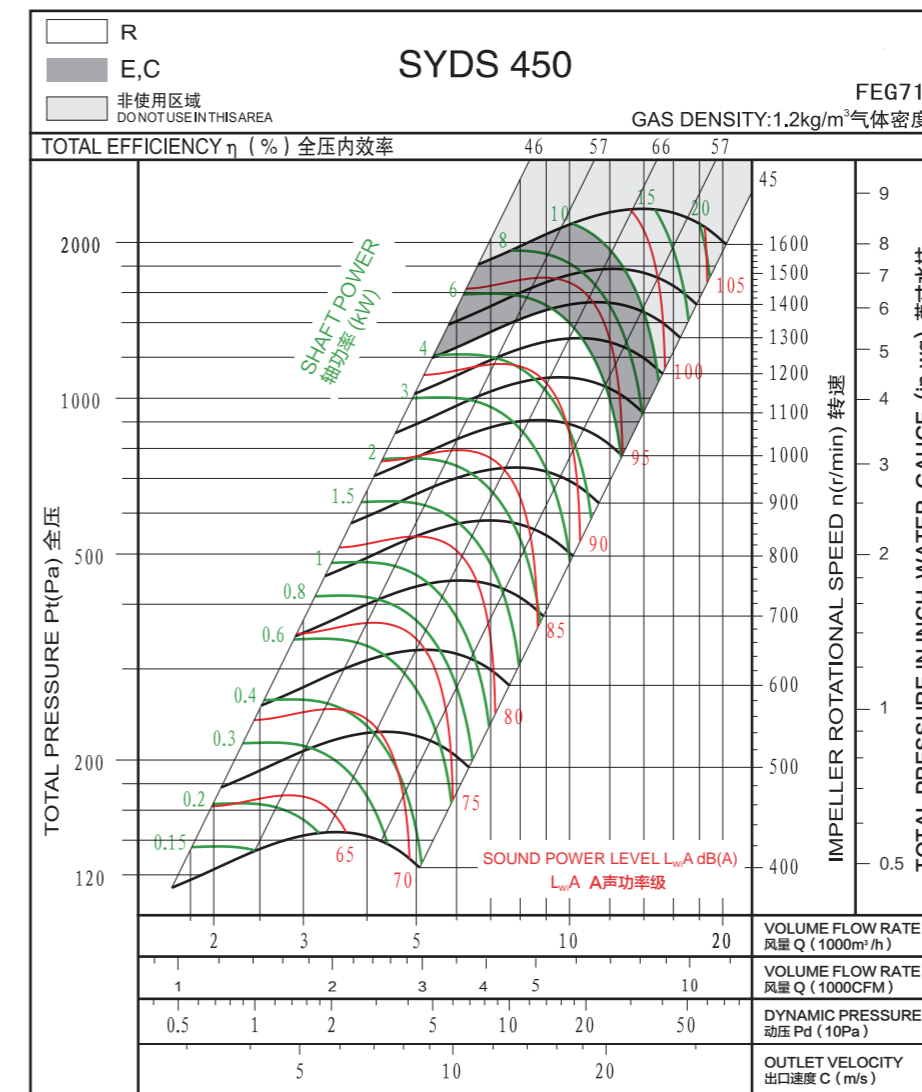
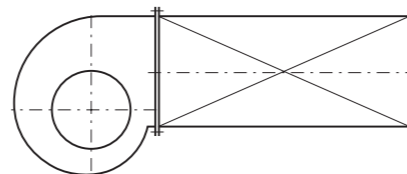

Measured in installation B according to AMCA Standard 210:

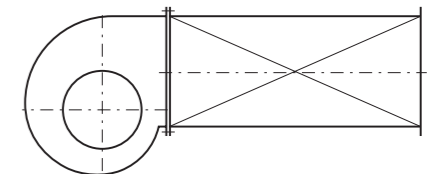

## 技术参数

## Technical Data

Wheel diameter 叶轮直径	D = 500 mm	Fan weight 风机质量	m = 85 kg
Moment of inertia 转动惯量	J = 0.5 kg·m <sup>2</sup>	Speed limit 极限转速	n <sub>max</sub> = 1300 r/min

## 技术参数

## Technical Data

Wheel diameter 叶轮直径	D = 560 mm	Fan weight 风机质量	m = 115 kg
Moment of inertia 转动惯量	J = 0.86 kg·m <sup>2</sup>	Speed limit 极限转速	n <sub>max</sub> = 1200 r/min

## 性能曲线

## Performance Curves

经认证的性能是B类安装：自由入口，管道出口。功率额定值(kW)不包括传输损失。各项性能额定值不包括附属物(附件)的影响。所示A加权声音性能额定值已按AMCA International标准301计算。所示值为安装类型B：自由入口，管道出口的声功率级（入口L<sub>wA</sub>）。

Performance certified is for installation type B: free inlet, ducted outlet. Power rating (kW) does not include transmission losses. Performance ratings do not include the effects of appurtenances (accessories). The A-weighted sound ratings shown have been calculated per AMCA International Standard 301. Values shown are for inlet L<sub>wA</sub> sound power levels for installation type B: free inlet, ducted outlet.

## 性能曲线

## Performance Curves

经认证的性能是B类安装：自由入口，管道出口。功率额定值(kW)不包括传输损失。各项性能额定值不包括附属物(附件)的影响。所示A加权声音性能额定值已按AMCA International标准301计算。所示值为安装类型B：自由入口，管道出口的声功率级（入口L<sub>wA</sub>）。

Performance certified is for installation type B: free inlet, ducted outlet. Power rating (kW) does not include transmission losses. Performance ratings do not include the effects of appurtenances (accessories). The A-weighted sound ratings shown have been calculated per AMCA International Standard 301. Values shown are for inlet L<sub>wA</sub> sound power levels for installation type B: free inlet, ducted outlet.

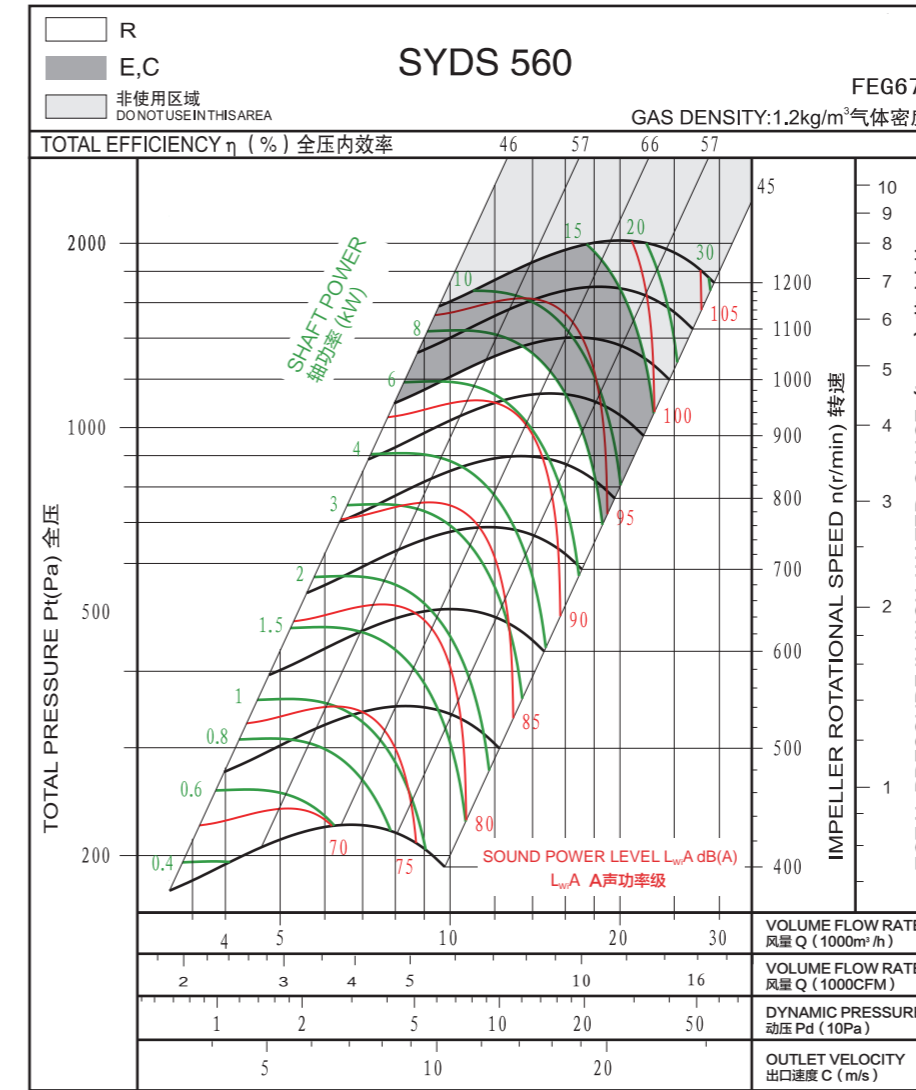
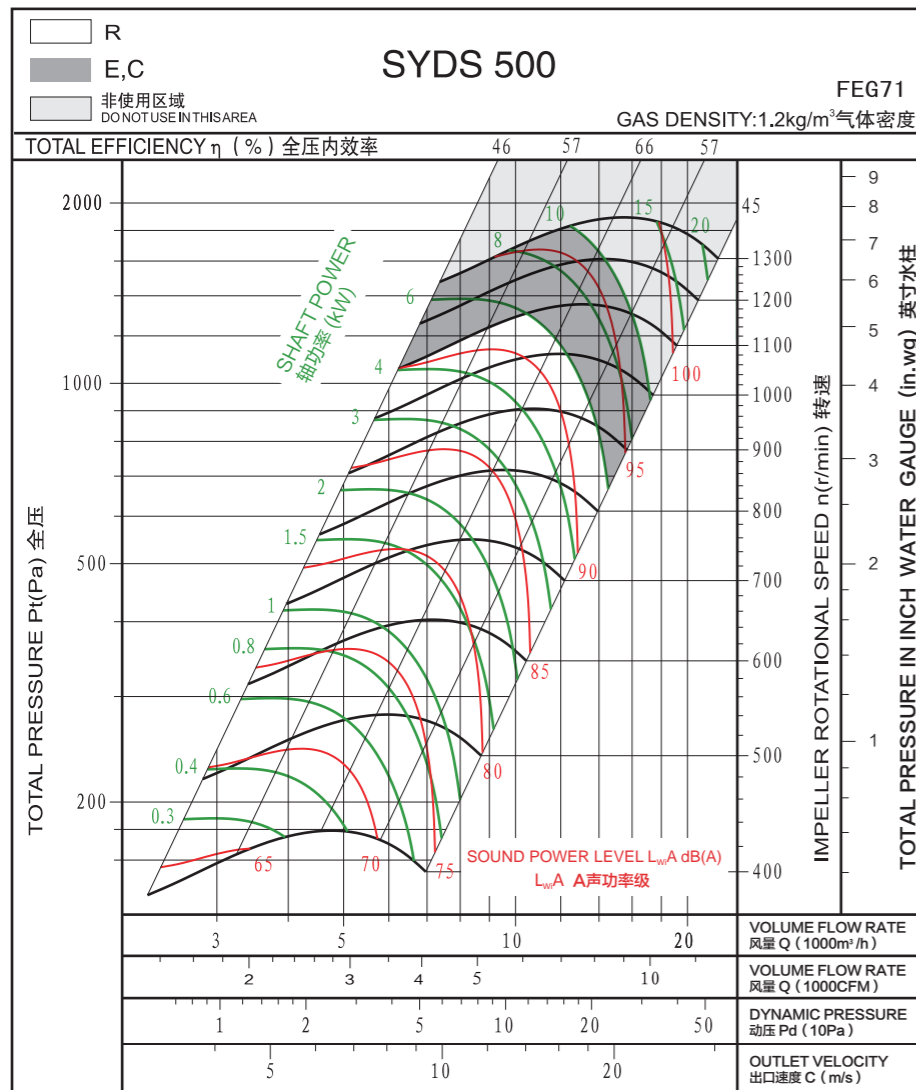

## 技术参数

## Technical Data

Wheel diameter 叶轮直径	D = 630 mm	Fan weight 风机质量	m = 130 kg
Moment of inertia 转动惯量	J = 1.42 kg·m <sup>2</sup>	Speed limit 极限转速	n <sub>max</sub> = 1000 r/min

## 技术参数

## Technical Data

Wheel diameter 叶轮直径	D = 710 mm	Fan weight 风机质量	m = 185 kg
Moment of inertia 转动惯量	J = 2.81 kg·m <sup>2</sup>	Speed limit 极限转速	n <sub>max</sub> = 900 r/min

## 性能曲线

## Performance Curves

经认证的性能是B类安装：自由入口，管道出口。功率额定值(kW)不包括传输损失。各项性能额定值不包括附属物(附件)的影响。所示A加权声音性能额定值已按AMCA International标准301计算。所示值为安装类型B：自由入口，管道出口的声功率级（入口L<sub>wA</sub>）。

Performance certified is for installation type B: free inlet, ducted outlet. Power rating (kW) does not include transmission losses. Performance ratings do not include the effects of appurtenances (accessories). The A-weighted sound ratings shown have been calculated per AMCA International Standard 301. Values shown are for inlet L<sub>wA</sub> sound power levels for installation type B: free inlet, ducted outlet.

## 性能曲线

## Performance Curves

经认证的性能是B类安装：自由入口，管道出口。功率额定值(kW)不包括传输损失。各项性能额定值不包括附属物(附件)的影响。所示A加权声音性能额定值已按AMCA International标准301计算。所示值为安装类型B：自由入口，管道出口的声功率级（入口L<sub>wA</sub>）。

Performance certified is for installation type B: free inlet, ducted outlet. Power rating (kW) does not include transmission losses. Performance ratings do not include the effects of appurtenances (accessories). The A-weighted sound ratings shown have been calculated per AMCA International Standard 301. Values shown are for inlet L<sub>wA</sub> sound power levels for installation type B: free inlet, ducted outlet.

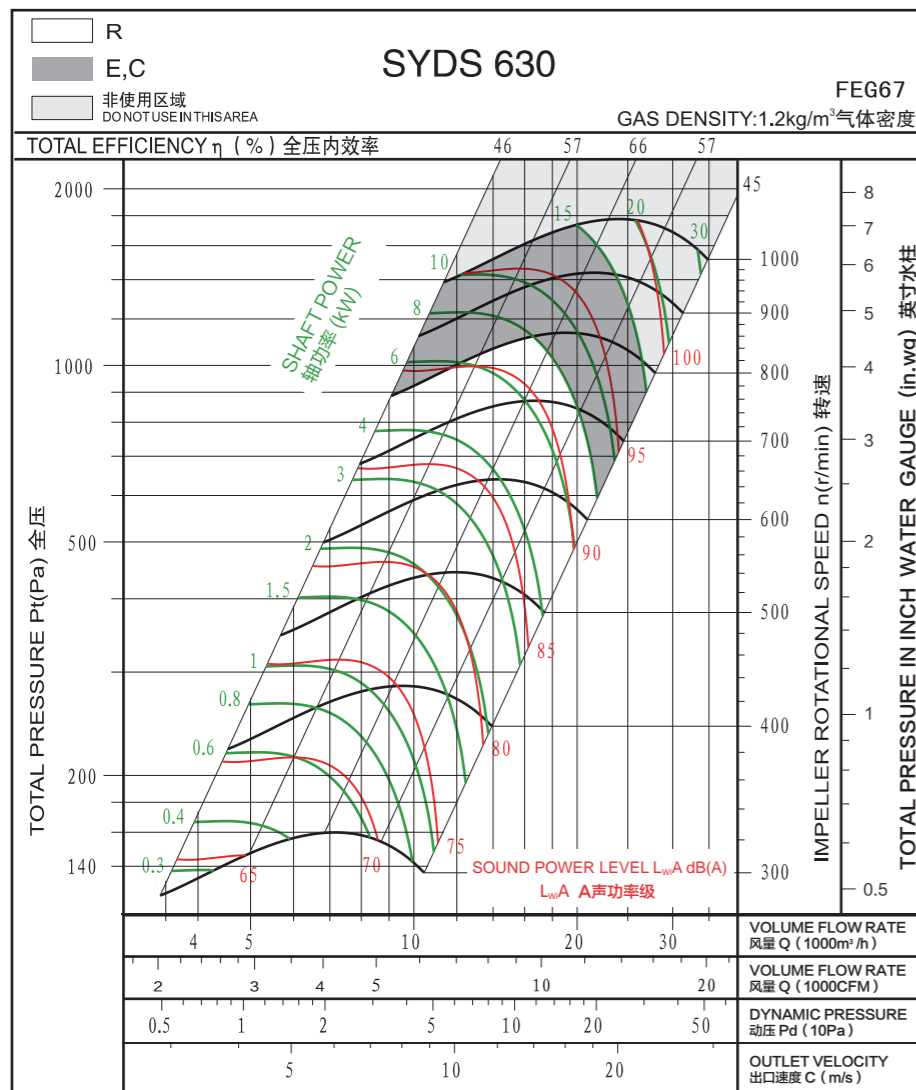

Measured in installation B according to AMCA Standard 210:

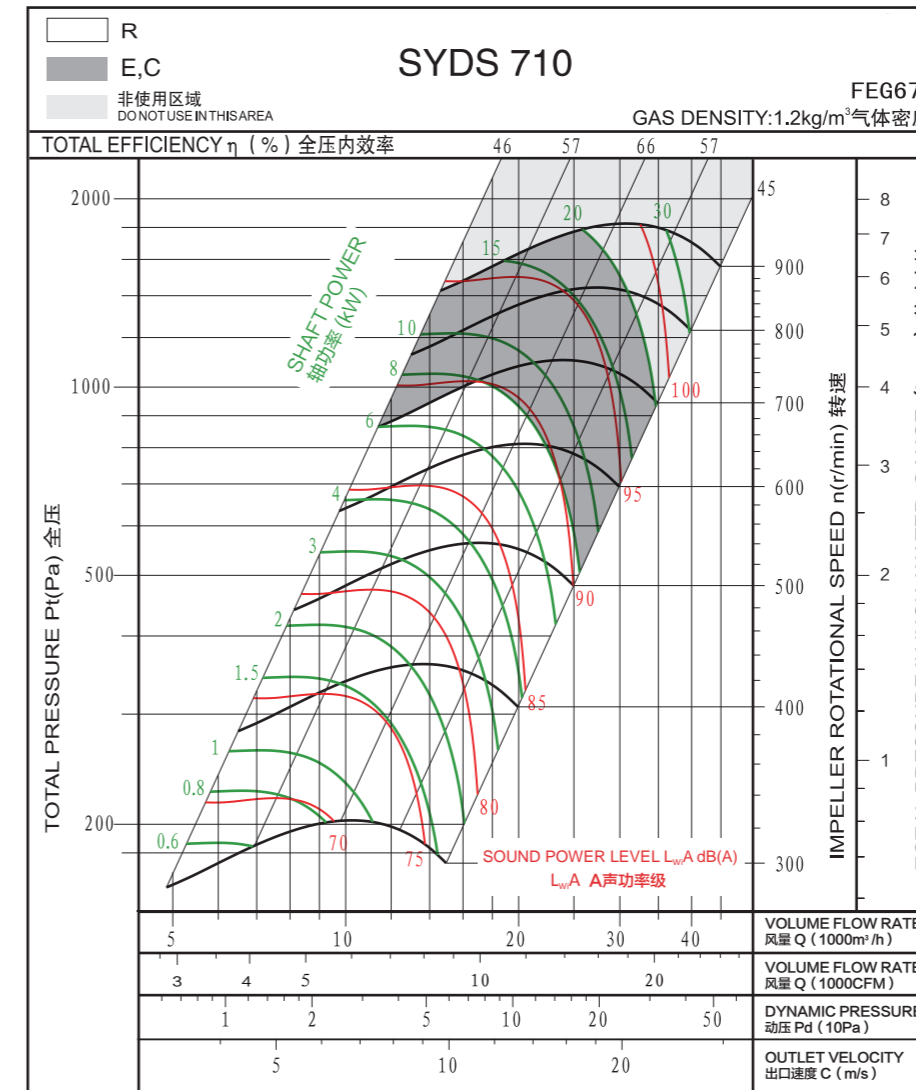
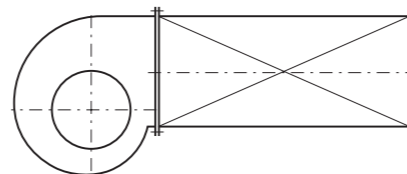

Measured in installation B according to AMCA Standard 210:

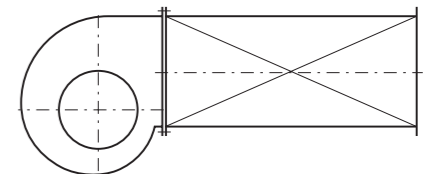



### 技术参数

### Technical Data

Wheel diameter 叶轮直径	D = 800 mm	Fan weight 风机质量	m = 230 kg
Moment of inertia 转动惯量	J = 4.59 kg·m <sup>2</sup>	Speed limit 极限转速	n <sub>max</sub> = 800 r/min

### 技术参数

### Technical Data

Wheel diameter 叶轮直径	D = 900 mm	Fan weight 风机质量	m = 280 kg
Moment of inertia 转动惯量	J = 6.93 kg·m <sup>2</sup>	Speed limit 极限转速	n <sub>max</sub> = 750 r/min

### 性能曲线

### Performance Curves

经认证的性能是B类安装：自由入口，管道出口。功率额定值(kW)不包括传输损失。各项性能额定值不包括附属物(附件)的影响。所示A加权声音性能额定值已按AMCA International标准301计算。所示值为安装类型B：自由入口，管道出口的声功率级（入口L<sub>wA</sub>）。

Performance certified is for installation type B: free inlet, ducted outlet. Power rating (kW) does not include transmission losses. Performance ratings do not include the effects of appurtenances (accessories). The A-weighted sound ratings shown have been calculated per AMCA International Standard 301. Values shown are for inlet L<sub>wA</sub> sound power levels for installation type B: free inlet, ducted outlet.

### 性能曲线

### Performance Curves

经认证的性能是B类安装：自由入口，管道出口。功率额定值(kW)不包括传输损失。各项性能额定值不包括附属物(附件)的影响。所示A加权声音性能额定值已按AMCA International标准301计算。所示值为安装类型B：自由入口，管道出口的声功率级（入口L<sub>wA</sub>）。

Performance certified is for installation type B: free inlet, ducted outlet. Power rating (kW) does not include transmission losses. Performance ratings do not include the effects of appurtenances (accessories). The A-weighted sound ratings shown have been calculated per AMCA International Standard 301. Values shown are for inlet L<sub>wA</sub> sound power levels for installation type B: free inlet, ducted outlet.

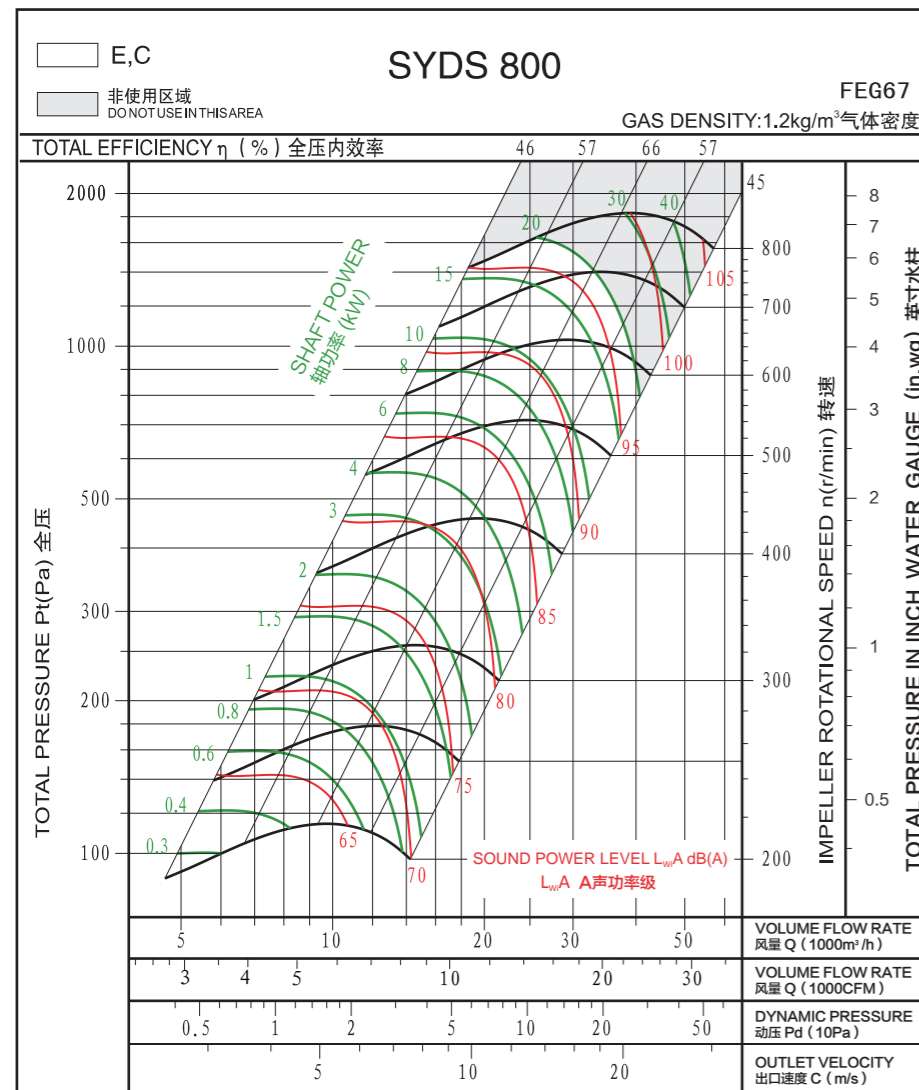

Measured in installation B according to AMCA Standard 210:

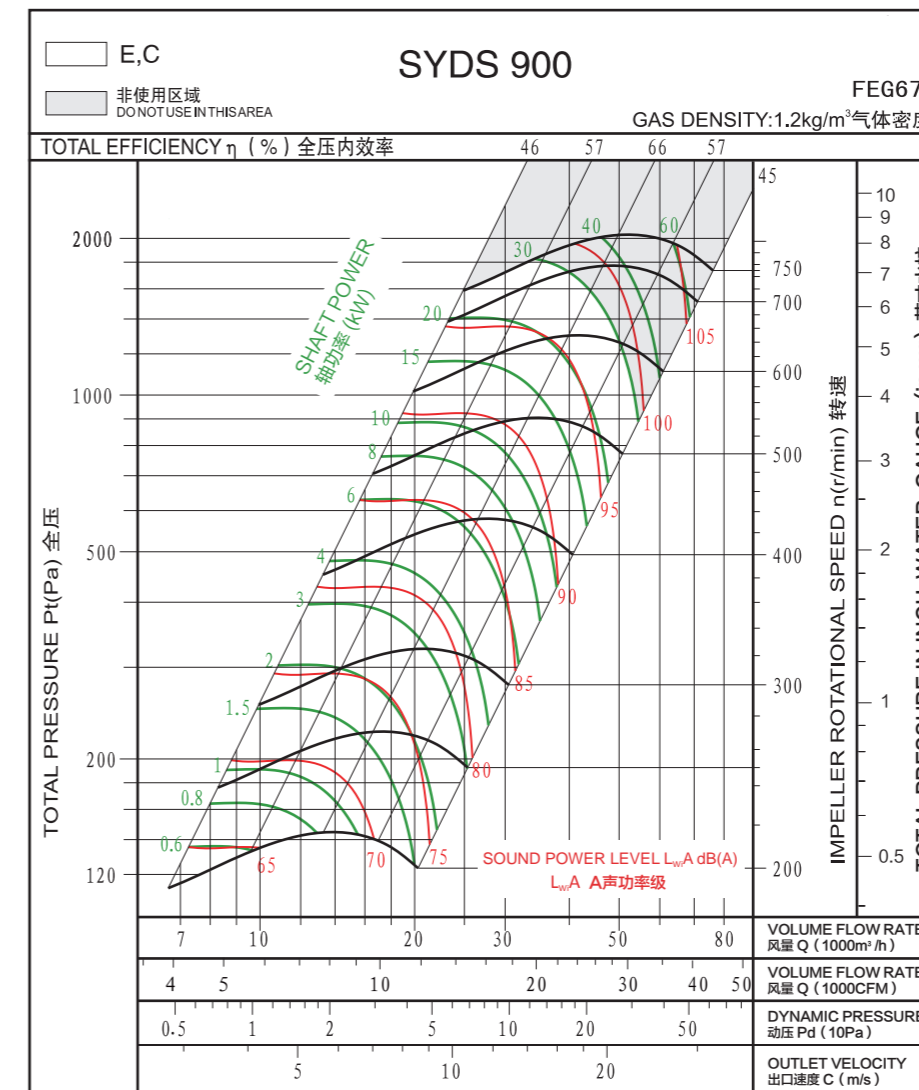
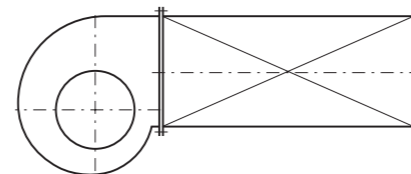

Measured in installation B according to AMCA Standard 210:

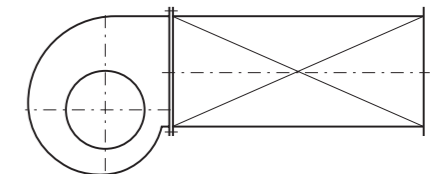

## 技术参数

## Technical Data

Wheel diameter 叶轮直径	D = 1000 mm	Fan weight 风机质量	m = 315 kg
Moment of inertia 转动惯量	J = 10.3 kg·m <sup>2</sup>	Speed limit 极限转速	n <sub>max</sub> = 650 r/min

## 性能曲线

## Performance Curves

经认证的性能是B类安装：自由入口，管道出口。功率额定值(kW)不包括传输损失。各项性能额定值不包括附属物(附件)的影响。所示A加权声音性能额定值已按AMCA International标准301计算。所示值为安装类型B：自由入口，管道出口的声功率级（入口L<sub>wA</sub>）。

Performance certified is for installation type B: free inlet, ducted outlet. Power rating (kW) does not include transmission losses. Performance ratings do not include the effects of appurtenances (accessories). The A-weighted sound ratings shown have been calculated per AMCA International Standard 301. Values shown are for inlet L<sub>wA</sub> sound power levels for installation type B: free inlet, ducted outlet.

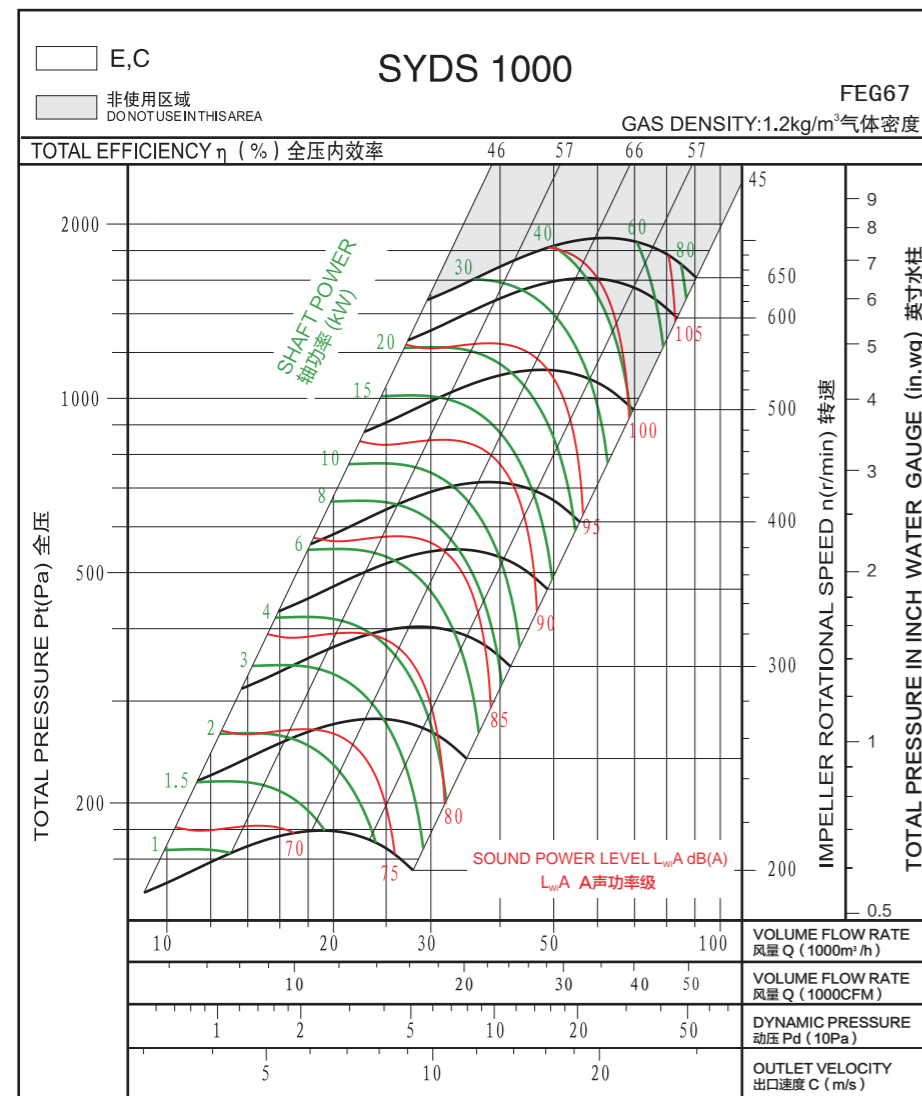

Measured in installation B according to AMCA Standard 210:

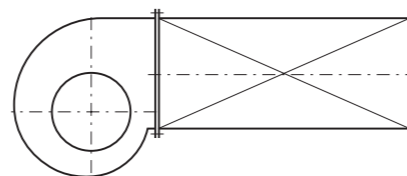

## 出口法兰

## Outlet Flange

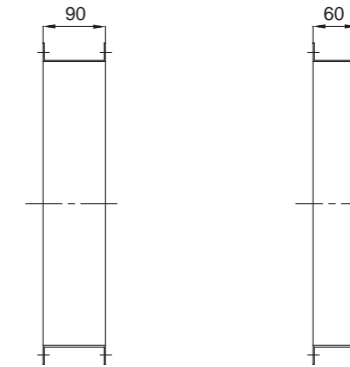
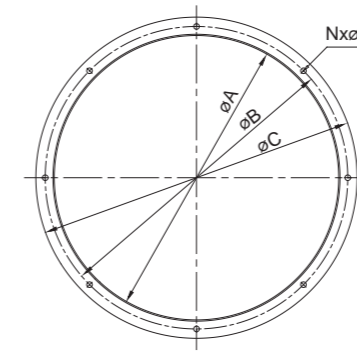

单位: mm

Dim	Module	280	315	355	400	450	500	560	630	710	800	900	1000
A		292	322	362	404	448	510	570	635	722	808	896	996
B		325	344	386	432	485	544	605	670	750	844	945	1044
C		355	383	423	466	515	570	635	700	778	875	980	1080
N-d		6x7	6x7	8x9	8x9	8x9	8x11	8x11	10x13	10x13	12x13	12x13	12x13

## 出口法兰

## Outlet Flange

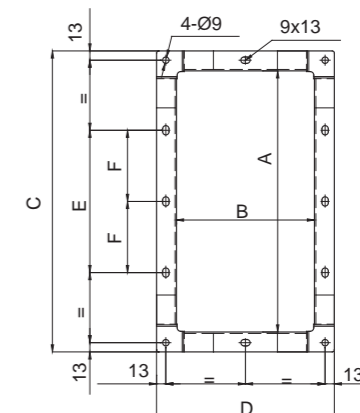
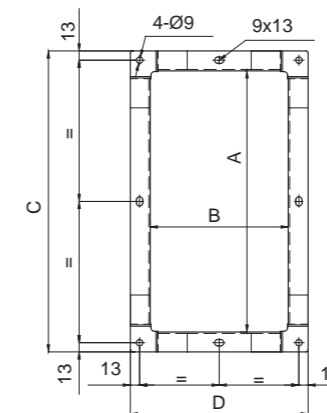

单位: mm

Dim	Module	280	315	355	400	450	500	560	630	710	800	900	1000
A		361	404	453	507	569	638	715	801	898	1007	1130	1267
B		197	223	238	258	288	324	368	412	468	520	580	663
C		417	460	509	563	625	684	771	857	954	1063	1186	1323
D		253	279	294	314	344	380	424	468	524	576	638	719
E		\	\	\	200	200	250	250	300	400	500	600	700
F		\	\	\	\	\	\	\	\	200	250	300	350

SYDS-R

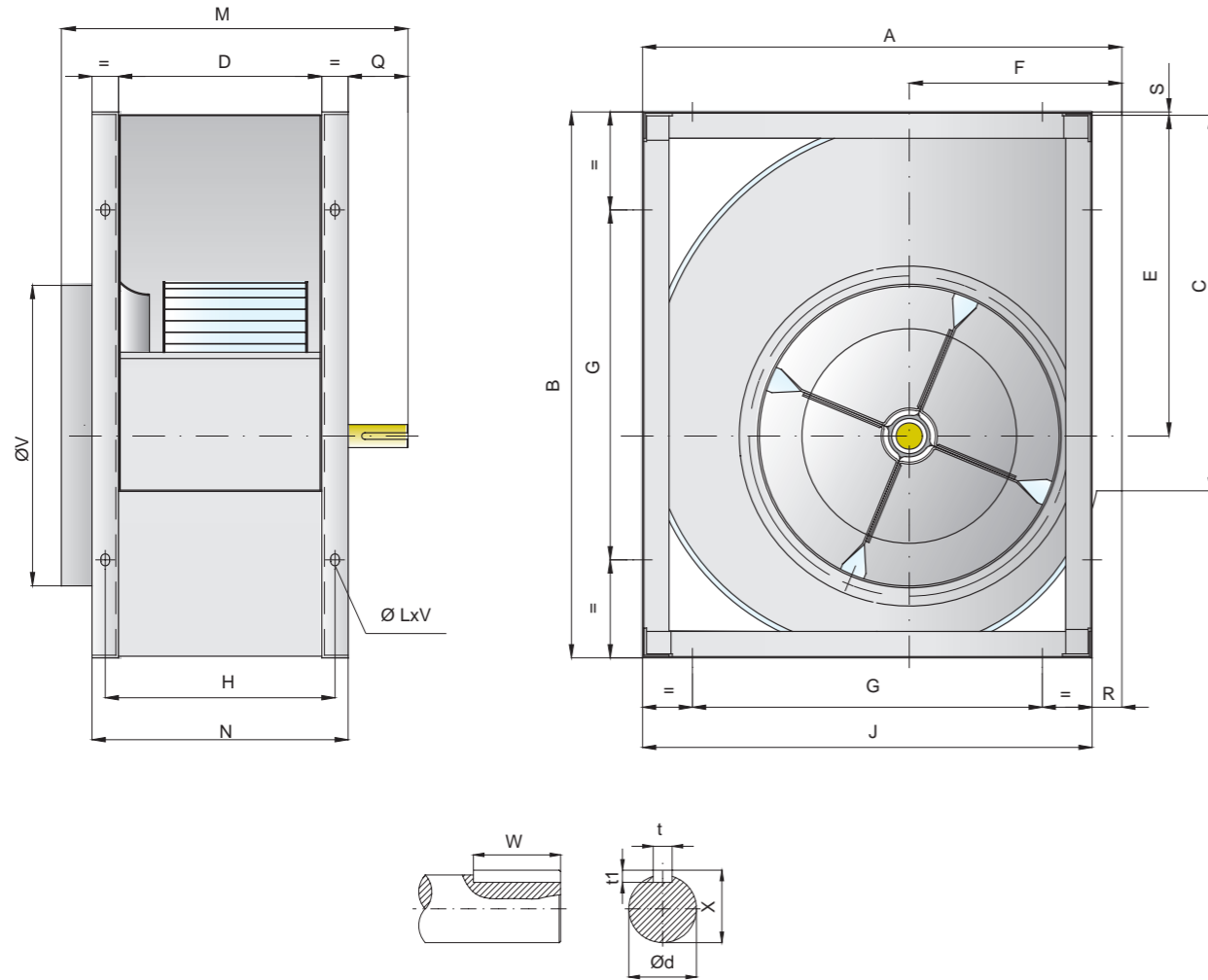

单位: mm

Model Dim	A	B	C	D	E	F	G	H	J	K	M	N	Q	R	S	V	t	t1	W	X	φd	LxV
280	466	518	361	197	302	215	280	227	432	30	360	257	73	34	5	292	8	7	50	28	25	13x18
315	518	578	404	223	340	236	280	253	480	30	395	283	83	38	3	322	8	7	60	28	25	13x18
355	578	655	453	238	383	261	355	278	548	40	416	318	78	30	6	362	8	7	60	33	30	13x18
400	651	736	507	258	431.5	290	355	298	613	40	436	338	78	38	4.5	404	8	7	60	33	30	13x18
450	726	827	569	288	486	322	530	338	681	40	480	368	92	45	5	448	10	8	70	38	35	13x18
500	800	918	638	324	538	352	530	364	750	40	515	404	92	50	5	510	10	8	70	38	35	13x18
560	893	1030	715	368	602	390	530	418	845	50	585	468	87	48	8	570	12	8	70	43	40	13x18
630	999	1157	801	412	678.5	434	530	468	946	50	630	512	87	53	7	635	14	9	70	48.5	45	13x18
710	1121	1303	898	468	765	485	630	518	1058	50	715	568	115	63	7	722	14	9	90	53.5	50	17x22

SYDS-C

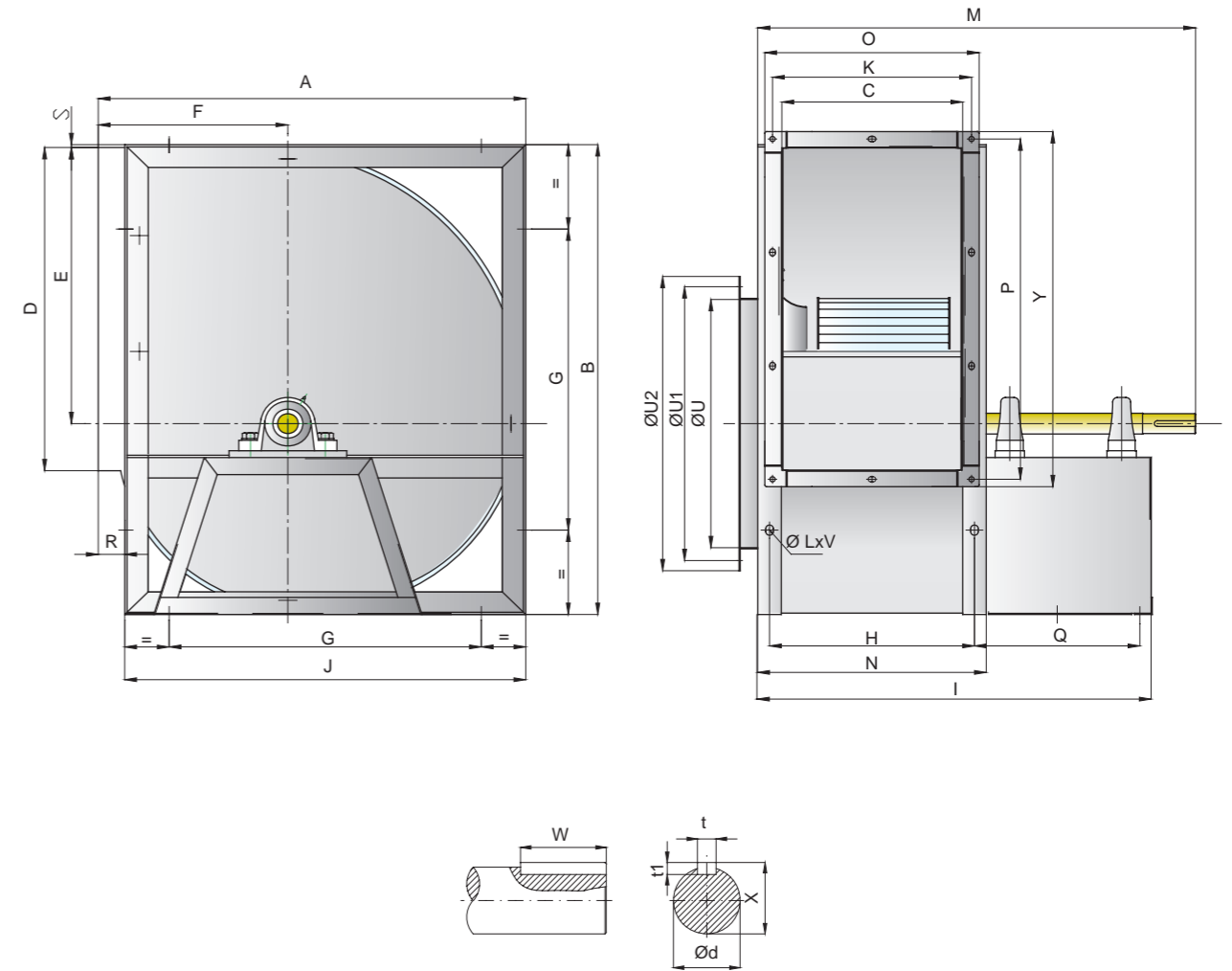

单位: mm

Model Dim	A	B	C	D	E	F	G	H	I	J	K	M	N	O	P	Q	R	S	t	t1	U	U1	U2	W	X	Y	φd	LxV
280	466	518	197	361	302	215	280	227	530	432	213	590	257	239	391	274	34	5	8	7	292	325	355	40	33	471	30	13x18
315	518	578	223	404	340	236	280	253	556	480	233	612	283	259	434	274	38	3	8	7	322	344	383	40	33	460	30	13x18
355	578	655	238	453	383	261	355	278	627	548	260	687	318	286	483	300	30	6	8	7	362	386	423	50	38	509	35	13x18
400	651	736	258	507	431.5	290	355	298	654	613	290	708	338	316	537	300	38	4.5	8	7	404	432	466	50	38	563	35	13x18
450	726	827	288	569	486	322	530	338	728	681	318	796	368	344	599	340	45	5	10	8	448	485	515	70	43	526	40	13x18
500	800	918	324	638	538	352	530	364	764	750	350	830	404	376	668	340	50	5	10	8	510	544	570	70	43	694	40	13x18
560	893	1030	368	715	603	390	530	418	855	845	366	930	468	414	745	378	48	8	12	8	570	605	635	90	53.5	771	50	13x18
630	999	1157	412	801	678.5	434	530	468	904	946	434	974	512	460	831	378	53	7	12	8	635	670	700	90	53.5	857	50	13x18
710	1121	1303	468	898	765	485	630	518	1005	1058	483	1105	568	512	928	436	63	7	14	9	722	750	778	90	64	954	60	17x22
800	1250	1468	520	1007	862	535	710	570	1060	1181	541	1167	620	567	1039	440	69	7	14	9	808	844	875	90	64	1063	60	17x22
900	1408	1648	582	1130	971	604	800	632	1191	1319	602	1300	702	613	1160	510	89	7	16	10	896	945	980	100	64	1186	60	17x22
1000	1541	1810	663	1267	1066	657	900	713	1259	1462	668	1381	783	694	1297	510	79	9	16	10	996	1044	1080	100	64	1323	60	17x22



SYDS-E

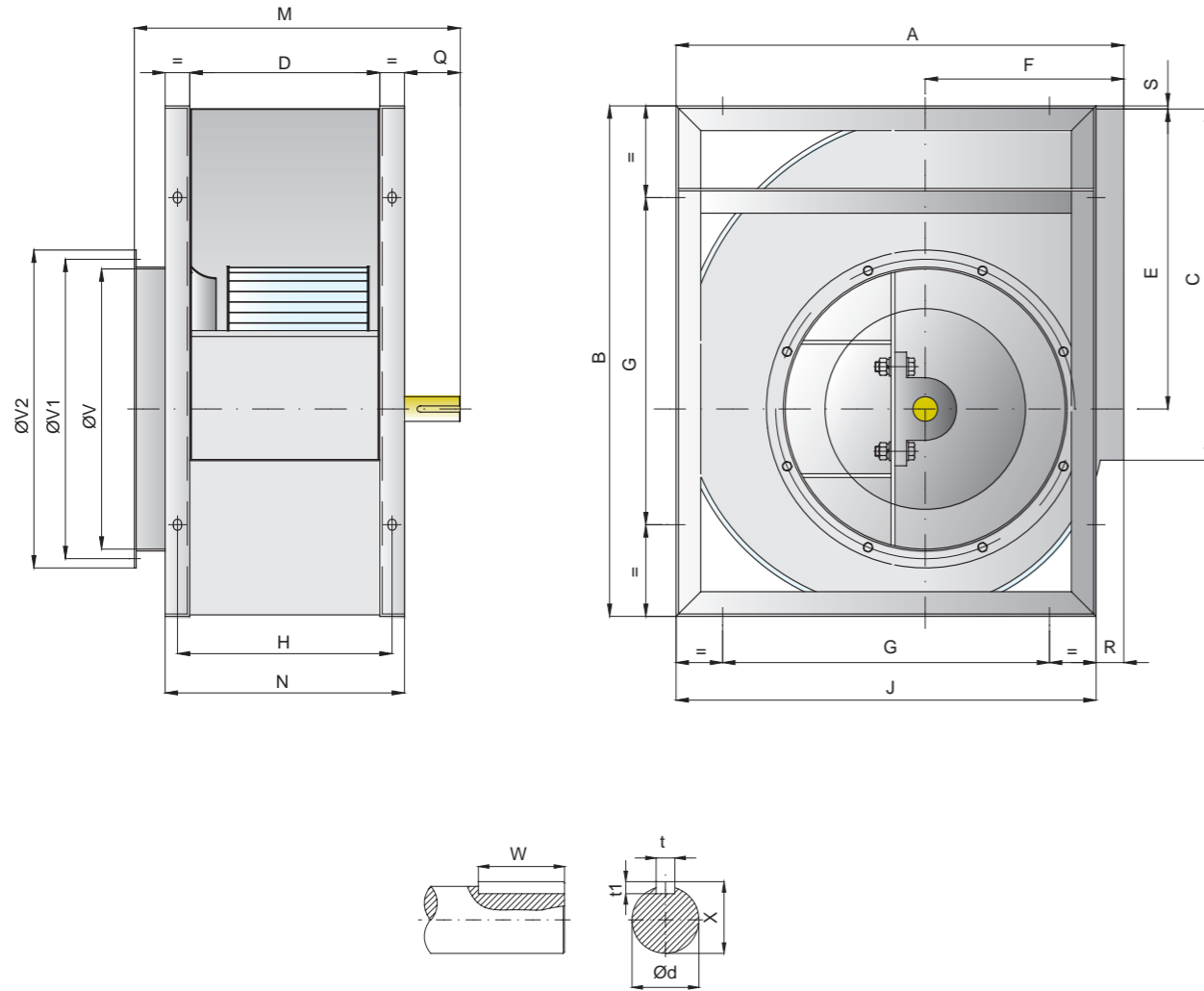

单位: mm

Model	A	B	C	D	E	F	G	H	J	K	M	N	Q	R	S	V	V1	V2	t	t <sub>1</sub>	W	X	φd	LxV
280	466	518	361	197	302	215	280	227	432	30	405	257	86	34	5	292	325	355	8	7	60	33	30	13x18
315	518	578	404	223	340	236	280	253	480	30	440	283	96	38	3	322	344	383	8	7	70	33	30	13x18
355	578	655	453	238	383	261	355	278	548	40	461	318	91	30	6	362	386	423	10	8	70	38	35	13x18
400	651	736	507	258	431.5	290	355	298	613	40	481	338	91	38	4.5	404	432	466	10	8	70	38	35	13x18
450	726	827	569	288	486	322	530	338	681	40	536	368	116	45	5	448	485	515	12	8	90	43	40	13x18
500	800	918	638	324	538	352	530	364	750	40	572	404	116	50	5	510	544	570	12	8	90	43	40	13x18
560	893	1030	715	368	602	390	530	418	845	50	625	468	115	48	8	570	605	635	14	9	90	53.5	50	13x18
630	999	1157	801	412	678.5	434	530	468	946	50	670	512	115	53	7	635	670	700	14	9	90	53.5	50	13x18
710	1121	1303	898	468	765	485	630	518	1058	50	736	568	126	63	7	722	750	778	18	11	90	64	60	17x22
800	1250	1468	1007	520	862	535	710	570	1181	50	788	620	126	69	7	808	844	875	18	11	90	64	60	17x22
900	1408	1648	1130	582	971	604	800	632	1319	60	867	702	135	89	7	896	945	980	18	11	100	64	60	17x22
1000	1541	1810	1267	663	1066	657	900	713	1462	60	950	783	135	79	9	996	1044	1080	18	11	100	64	60	17x22

SYDS-C

		0°				90°				180°			
		左旋 LG Left Hand		右旋 RD Right Hand		左旋 LG Left Hand		右旋 RD Right Hand		左旋 LG Left Hand		右旋 RD Right Hand	
型号	电机	L	A	B	C	L	A	B	C	L	A	B	C
280	80	425	760	675	568	375	850	675	516	410	760	675	568
	90	435	780	675	568	385	860	675	516	420	780	675	568
	100	445	800	675	568	395	880	675	516	430	800	675	568
	112	455	850	675	568	405	930	675	516	440	850	675	568
	132	465	870	675	568	415	950	675	516	450	870	675	568
315	80	465	800	700	628	405	900	700	568	440	800	700	628
	90	475	820	700	627	415	920	700	568	450	820	700	627
	100	485	850	700	628	425	950	700	568	460	850	700	628
	112	495	900	700	628	435	1000	700	568	470	900	700	628
	132	505	920	700	628	445	1020	700	568	480	920	700	628
355	80	515	850	775	705	445	1000	775	628	480	850	775	705
	90	525	860	775	705	455	1000	775	628	490	860	775	705
	100	535	900	775	705	465	1040	775	628	500	900	775	705
	112	545	960	775	705	475	1080	775	628	510	960	775	705
	132	555	980	775	705	485	1100	775	628	520	980	775	705
400	90	585	930	800	786	500	950	800	701	540	930	800	786
	100	595	980	800	786	510	1000	800	701	550	980	800	786
	112	605	1030	800	786	520	1160	800	701	560	1030	800	786
	132	615	1050	800	786	530	1180	800	701	570	1050	800	786
	160	615	1100	800	786	530	1230	800	701	570	1100	800	786
450	90	650	1000	894	877	548	1120	894	776	590	1000	894	877
	100	660	1050	894	877	558	1170	894	776	600	1050	894	877
	112	670	1100	894	877	568	1220	894	776	610	1100	894	877
	132	680	1120	894	877	578	1270	894	776	620	1120	894	877
	160	680	1200	894	877	578	1350	894	776	620	1200	894	877
500	90	720	1100	930	968	610	1250	930	850	650	1100	930	968
	100	730	1130	930	968	620	1280	930	850	660	1130	930	968
	112	740	1180	930	968	630	1330	930	850	670	1180	930	968
	132	750	1200	930	968	640	1350	930	850	680	1200	930	968
	160	750	1280	930	968	640	1440	930	850	680	1280	930	968

SYDS-C

型号	电机	0°				90°				180°			
		L	A	B	C	L	A	B	C	L	A	B	C
560	100	805	1210	1020	1093	680	1370	1020	956	720	1210	1020	1093
	112	815	1260	1020	1093	690	1420	1020	956	730	1260	1020	1093
	132	825	1280	1020	1093	700	1460	1020	956	740	1280	1020	1093
	160	835	1360	1020	1093	710	1540	1020	956	750	1360	1020	1093
	180	845	1400	1020	1093	720	1580	1020	956	760	1400	1020	1093
630	100	895	1310	1065	1220	755	1530	1065	1062	795	1310	1065	1220
	112	905	1360	1065	1220	765	1580	1065	1062	805	1360	1065	1220
	132	915	1380	1065	1220	775	1600	1065	1062	815	1380	1065	1220
	160	930	1450	1065	1220	790	1680	1065	1062	830	1450	1065	1220
	180	940	1500	1065	1220	800	1730	1065	1062	840	1500	1065	1220
	200	950	1550	1065	1220	810	1780	1065	1062	850	1550	1065	1220
710	100	1005	1430	1185	1366	840	1670	1185	1184	885	1430	1185	1366
	112	1015	1480	1185	1366	850	1720	1185	1184	895	1480	1185	1366
	132	1025	1500	1185	1366	860	1740	1185	1184	905	1500	1185	1366
	160	1040	1570	1185	1366	875	1800	1185	1184	920	1570	1185	1366
	180	1050	1620	1185	1366	885	1850	1185	1184	930	1620	1185	1366
	200	1060	1670	1185	1366	895	1900	1185	1184	940	1670	1185	1366
	225	1070	1700	1185	1366	905	1930	1185	1184	950	1700	1185	1366
800	112	1130	1580	1245	1548	950	1880	1245	1330	990	1580	1245	1548
	132	1140	1600	1245	1548	960	1900	1245	1330	1000	1600	1245	1548
	160	1155	1650	1245	1548	975	1950	1245	1330	1015	1650	1245	1548
	180	1165	1720	1245	1548	985	2020	1245	1330	1025	1720	1245	1548
	200	1175	1770	1245	1548	995	2070	1245	1330	1035	1770	1245	1548
	225	1185	1820	1245	1548	1005	2120	1245	1330	1045	1820	1245	1548
900	112	1270	1730	1375	1728	1060	2060	1375	1488	1110	1730	1375	1728
	132	1280	1750	1375	1728	1070	2080	1375	1488	1110	1750	1375	1728
	160	1295	1800	1375	1728	1085	2130	1375	1488	1125	1800	1375	1728
	180	1310	1880	1375	1728	1095	2220	1375	1488	1135	1880	1375	1728
	200	1320	1920	1375	1728	1105	2250	1375	1488	1145	1920	1375	1728
	225	1330	1980	1375	1728	1115	2320	1375	1488	1155	1980	1375	1728
1000	132	1400	1900	1450	1890	1175	2250	1450	1621	1215	1900	1450	1890
	160	1415	1950	1450	1890	1190	2300	1450	1621	1230	1950	1450	1890
	180	1425	2030	1450	1890	1200	2380	1450	1621	1240	2030	1450	1890
	200	1435	2070	1450	1890	1210	2420	1450	1621	1250	2070	1450	1890
	225	1445	2130	1450	1890	1220	2480	1450	1621	1260	2130	1450	1890
	250	1455	2200	1450	1890	1230	2550	1450	1621	1270	2200	1450	1890
280	1465	2250	1450	1890	1240	2600	1450	1621	1280	2250	1450	1890	

SYDS-E

型号	电机	0°				90°				180°			
		L	A	B	C	L	A	B	C	L	A	B	C
280	80	425	760	430	568	375	850	430	516	410	760	430	568
	90	435	780	430	568	385	860	430	516	420	780	430	568
	100	445	800	430	568	395	880	430	516	430	800	430	568
	112	455	850	430	568	405	930	430	516	440	850	430	568
	132	465	870	430	568	415	950	430	516	450	870	430	568
315	80	465	800	465	628	405	900	465	568	440	800	465	628
	90	475	820	465	627	415	920	465	568	450	820	465	627
	100	485	850	465	628	425	950	465	568	460	850	465	628
	112	495	900	465	628	435	1000	465	568	470	900	465	628
355	80	515	850	495	705	445	1000	495	628	480	850	495	705
	90	525	860	495	705	455	1000	495	628	490	860	495	705
	100	535	900	495	705	465	1040	495	628	500	900	495	705
	112	545	960	495	705	475	1080	495	628	510	960	495	705
	132	555	980	495	705	485	1100	495	628	520	980	495	705
400	90	585	930	525	786	500	950	525	701	540	930	525	786
	100	595	980	525	786	510	1000	525	701	550	980	525	786
	112	605	1030	525	786	520	1160	525	701	560	1030	525	786
	132	615	1050	525	786	530	1180	525	701	570	1050	525	786
	160	615	1100	525	786	530	1230	525	701	570	1100	525	786
450	90	650	1000	580	877	548	1120	580	776	590	1000	580	877
	100	660	1050	580	877	558	1170	580	776	600	1050	580	877
	112	670	1100	580	877	568	1220	580	776	610	1100	580	877
	132	680	1120	580	877	578	1270	580	776	620	1120	580	877
500	160	680	1200	580	877	578	1350	580	776	620	1200	580	877
	90	720	1100	620	968	610	1250	620	850	650	1100	620	968
	100	730	1130	620	968	620	1280	620	850	660	1130	620	968
	112	740	1180	620	968	630	1330	620	850	670	1180	620	968
	132	750	1200	620	968	640	1350	620	850	680	1200	620	968
160	750	1280	620	968	640	1440	620	850	680	1280	620	968	

SYDS-E

型号	电机	0°				90°				180°			
		L	A	B	C	L	A	B	C	L	A	B	C
560	100	805	1210	665	1093	680	1370	665	956	720	1210	665	1093
	112	815	1260	665	1093	690	1420	665	956	730	1260	665	1093
	132	825	1280	665	1093	700	1460	665	956	740	1280	665	1093
	160	835	1360	665	1093	710	1540	665	956	750	1360	665	1093
	180	845	1400	665	1093	720	1580	665	956	760	1400	665	1093
630	100	895	1310	715	1220	755	1530	715	1062	795	1310	715	1220
	112	905	1360	715	1220	765	1580	715	1062	805	1360	715	1220
	132	915	1380	715	1220	775	1600	715	1062	815	1380	715	1220
	160	930	1450	715	1220	790	1680	715	1062	830	1450	715	1220
	180	940	1500	715	1220	800	1730	715	1062	840	1500	715	1220
710	200	950	1550	715	1220	810	1780	715	1062	850	1550	715	1220
	100	1005	1430	770	1366	840	1670	770	1184	885	1430	770	1366
	112	1015	1480	770	1366	850	1720	770	1184	895	1480	770	1366
	132	1025	1500	770	1366	860	1740	770	1184	905	1500	770	1366
	160	1040	1570	770	1366	875	1800	770	1184	920	1570	770	1366
	180	1050	1620	770	1366	885	1850	770	1184	930	1620	770	1366
800	200	1060	1670	770	1366	895	1900	770	1184	940	1670	770	1366
	225	1070	1700	770	1366	905	1930	770	1184	950	1700	770	1366
	112	1130	1580	825	1548	950	1880	825	1330	990	1580	825	1548
	132	1140	1600	825	1548	960	1900	825	1330	1000	1600	825	1548
	160	1155	1650	825	1548	975	1950	825	1330	1015	1650	825	1548
	180	1165	1720	825	1548	985	2020	825	1330	1025	1720	825	1548
900	200	1175	1770	825	1548	995	2070	825	1330	1035	1770	825	1548
	225	1185	1820	825	1548	1005	2120	825	1330	1045	1820	825	1548
	250	1195	1880	825	1548	1015	2180	825	1330	1055	1880	825	1548
	112	1270	1730	905	1728	1060	2060	905	1488	1110	1730	905	1728
	132	1280	1750	905	1728	1070	2080	905	1488	1110	1750	905	1728
	160	1295	1800	905	1728	1085	2130	905	1488	1125	1800	905	1728
1000	180	1310	1880	905	1728	1095	2220	905	1488	1135	1880	905	1728
	200	1320	1920	905	1728	1105	2250	905	1488	1145	1920	905	1728
	225	1330	1980	905	1728	1115	2320	905	1488	1155	1980	905	1728
	250	1340	2050	905	1728	1125	2380	905	1488	1165	2050	905	1728
	132	1400	1900	975	1890	1175	2250	975	1621	1215	1900	975	1890
	160	1415	1950	975	1890	1190	2300	975	1621	1230	1950	975	1890
1000	180	1425	2030	975	1890	1200	2380	975	1621	1240	2030	975	1890
	200	1435	2070	975	1890	1210	2420	975	1621	1250	2070	975	1890
	225	1445	2130	975	1890	1220	2480	975	1621	1260	2130	975	1890
	250	1455	2200	975	1890	1230	2550	975	1621	1270	2200	975	1890
	280	1465	2250	975	1890	1240	2600	975	1621	1280	2250	975	1890

SYDS-R

型号	电机	0°				90°				180°			
		L	A	B	C	L	A	B	C	L	A	B	C
280	71	415	740	400	568	365	830	400	516	400	740	400	568
	80	425	760	400	568	375	850	400	516	410	760	400	568
	90	435	780	400	568	385	860	400	516	420	780	400	568
	100	445	800	400	568	395	880	400	516	430	800	400	568
	112	455	850	400	568	405	930	400	516	440	850	400	568
315	71	455	780	435	628	395	880	435	568	430	780	435	628
	80	465	800	435	628	405	900	435	568	440	800	435	628
	90	475	820	435	628	415	920	435	568	450	820	435	628
	100	485	850	435	628	425	950	435	568	460	850	435	628
355	112	495	900	435	628	435	1000	435	568	470	900	435	628
	71	505	830	465	705	435	960	465	628	470	830	465	705
	80	515	850	465	705	445	980	465	628	480	850	465	705
400	90	525	860	465	705	455	1000	465	628	490	860	465	705
	100	535	900	465	705	465	1040	465	628	500	900	465	705
	112	545	960	465	705	475	1080	465	628	510	960	465	705
	71	565	880	495	786	480	900	495	701	520	880	495	786
450	80	575	900	495	786	490	920	495	701	530	900	495	786
	90	585	930	495	786	500	950	495	701	540	930	495	786
	100	595	980	495	786	510	1000	495	701	550	980	495	786
	112	605	1030	495	786	520	1160	495	701	560	1030	495	786
	132	615	1050	495	786	530	1180	495	701	570	1050	495	786
500	80	640	980	550	877	548	1100	550	776	580	980	550	877
	90	650	1000	550	877	548	1120	550	776	590	1000	550	877
	100	660	1050	550	877	558	1170	550	776	600	1050	550	877
	112	670	1100	550	877	568	1220	550	776	610	1100	550	877
500	132	680	1120	550	877	578	1270	550	776	620	1120	550	877
	80	710	1080	590	968	600	1230	590	850	640	1080	590	968
	90	720	1100	590	968	610	1250	590	850	650	1100	590	968
	100	730	1130	590	968	620	1280	590	850	660	1130	590	968
	112	740	1180	590	968	630	1330	590	850	670	1180	590	968
132	750	1200	590	968	640	1350	590	850	680	1200	590	968	



## SYDS-R

型号	电机	0°				90°				180°			
		L	A	B	C	L	A	B	C	L	A	B	C
560	90	795	1160	635	1093	670	1320	635	956	710	1160	635	1093
	100	805	1210	635	1093	680	1370	635	956	720	1210	635	1093
	112	815	1260	635	1093	690	1420	635	956	730	1260	635	1093
	132	825	1280	635	1093	700	1460	635	956	740	1280	635	1093
	160	835	1360	635	1093	710	1540	635	956	750	1360	635	1093
630	90	885	1260	685	1220	745	1480	685	1062	785	1260	685	1220
	100	895	1310	685	1220	755	1530	685	1062	795	1310	685	1220
	112	905	1360	685	1220	765	1580	685	1062	805	1360	685	1220
	132	915	1380	685	1220	775	1600	685	1062	815	1380	685	1220
	160	930	1450	685	1220	790	1680	685	1062	830	1450	685	1220
710	90	995	1380	740	1366	830	1620	740	1184	875	1380	740	1366
	100	1005	1430	740	1366	840	1670	740	1184	885	1430	740	1366
	112	1015	1480	740	1366	850	1720	740	1184	895	1480	740	1366
	132	1025	1500	740	1366	860	1740	740	1184	905	1500	740	1366
	160	1040	1570	740	1366	875	1800	740	1184	920	1570	740	1366

注: L=风机轮与电机轮之间的中心距  
L=center distance between fan and motor pulley

## SYDS系列风机运行极限

## SYDS Series Fan Operational Limits

			280	315	355	400	450	500	560	630	710	800	900	1000
极限吸收功率 Max. Absorbed power	R	KW	4	6	3	4	6	6	8	8	10	\	\	\
	E	KW	4	6	6	8	10	10	15	15	20	20	30	40
	C	KW	4	6	6	8	10	10	15	15	20	20	30	40
极限转速 Max. Speed	R	rpm	2400	2000	1800	1500	1300	1100	1000	800	700	\	\	\
	E	rpm	2400	2000	2000	1800	1600	1300	1200	1000	900	800	750	650
	C	rpm	2400	2000	2000	1800	1600	1300	1200	1000	900	800	750	650
极限温度(最低-20℃) Air Temperature Limits (Min-20℃)	R	Max.℃	85	85	85	85	85	85	85	85	85	\	\	\
	E	Max.℃	85	85	85	85	85	85	85	85	85	85	85	85
	C	Max.℃	180	180	180	180	180	180	180	180	180	180	180	180
风机质量 Fan Weight	R	Kg	15	17	21	30	37	48	60	76	125	\	\	\
	E	Kg	23	26	39	46	51	70	95	110	162	200	245	275
	C	Kg	30	33	48	57	65	85	115	130	185	230	280	315

本样本中所述的风机特性, 如尺寸、性能参数等, 本公司保留更改的权利, 恕不另行通知; 如有不明之处, 请来电询问。  
This fan features described in the sample, such as size, performance parameters, the Company reserves the right to change without notice; if unknown place, please call us.